

# SERVICES & WARNINGS

1

## **Amick Associates, Inc. Offers:**

- Inspection and Repair
- Proof Testing and Certification
- Pre-stressing
- Additional Services Offered
- Safety and Training Seminars
- Chain Inspections and Repairs
- Wire Rope Inspections and Repairs
- Magnetic Particle Inspections
- On-Site Hoist Inspections and Repairs

## **Warnings**

# SERVICES & WARNINGS

Amick Associates, Inc.

Amick Associates, Inc. Offers:

version #2-04

1

## Amick Associates, Inc. Offers:

- In-plant sling inspections.
- In-plant crane and hoist rope inspections.
- Magnetic particle inspection of hooks and fittings.
- Safety seminars on lifting products and applications.
- Design and engineering of lifting apparatus.
- Slings designed for any application.

### Inspection and Repair of:

- Alloy chain slings.
- Wire rope slings.
- Wire mesh slings.
- Nylon web slings.
- Special chain slings.
- Electric hoists.
- Hand hoists.
- Wire rope pullers.
- Plate clamps.
- Chain pullers.

### Proof Testing and Certification of:

- Wire rope slings.
- Wire mesh slings.
- Nylon web slings.
- Alloy chain slings.
- All types of special assemblies.

### Pre-stressing of:

- Wire rope.
- Wire rope assemblies.
- Boom pendants.
- Special assemblies.

All testing and pre-stressing done in our modern 200,000 pound pull tester.

### Additional Services Offered are:

- Machining of new crane hooks to fit existing blocks.
- Documented wire rope surveys to identify and determine proper construction for your wire rope applications.
- Knowledge of and adherence to all federal specifications.
- Special packaging and handling of customers' orders when specified.
- Prompt service to towing trucks and utility vehicles.
- Trained and experienced field personnel for problem solving in overhead lifting, loading securement, and high pressure hydraulics.

### Safety and Training Seminars

Amick Associates takes great pride in our service and safety programs. Our "Planning a Safe Lift" safety program deals with lifting awareness and safety. It is this service aspect of our company that sets us apart from our competitors in the industry.

Amick has several instructors with a Level 3 Certification for rigging training.

Our seminars would be available at your convenience and would take approximately one hour. Multiple seminars can also be scheduled to suit your needs. Amick instructors will speak on lifting safety in conjunction with a video program. Also, various product samples will be demonstrated for the retirement criteria portion. The entire program is designed to bring your company into compliance with ANSI B30.9 and OSHA 1910 specifications. The program is tailored to the needs of your company and it could cover one or more of the following items:

- Wire rope.
- Wire rope slings.
- Alloy chain slings.
- Synthetic web slings.
- Wire mesh slings.
- Wire rope on cranes.

"Planning a Safe Lift" takes good decision making by everyone involved. Our goal during a seminar is to bring in-plant lifting awareness to each individual, with the intention of creating a safer overhead lift environment within the plant.

- Hoist Safety Training Seminars.
- Fall Protection Safety Training Seminars.

### Chain Inspections and Repairs

As part of our comprehensive service and safety programs for our valued customers, Amick Associates offers regularly scheduled chain inspections. Customers can schedule chain inspections annually, semi-annually, or quarterly with minimal interruption of plant work schedules.

#### About the Inspection

- Chains are visually inspected for wear, cracks, gouges, and deformations of the chain slings and lifting devices.
- A customer representative may join the inspection if he/she wishes to do so, however, it is not required.
- Any items failing inspection will be danger tagged and removed from service immediately.
- Before leaving the customer's premises, the Amick chain inspector will review the inspection with a customer representative to discuss corrective action or procedures.
- A complete, written inspection report will be sent to the customer one week after the inspection detailing the condition of every chain inspected.

#### About the Repairs

- Chains danger tagged will be brought back to Amick Associates, home of the largest chain repair station in western Pennsylvania. We are capable of repairing and/or replacing all brands of chain and fittings with a minimal turnaround time.
- Customers will receive a 'new vs. repair' quote before any corrective action is taken.

## Wire Rope Inspections and Repairs

In our never-ending effort to keep our customer's overhead lifting products safe and reliable, Amick Associates offers wire rope inspections. Customers can schedule wire rope inspections annually, semi-annually, or quarterly with minimal interruption of plant work schedules.

All wire ropes will wear out eventually and gradually lose work capability throughout their service life. That's why periodic inspections are critical. Applicable industry standards such as ASME B30.2 for overhead and gantry cranes or federal regulations such as OSHA refer to specific inspection criteria for varied applications.

### Three Purposes for Inspection

- Reveals the rope's condition and indicates a possible need for replacement.
- Indicates if you are using the most suitable type of rope for the given application.
- Makes possible the discovery and correction of faults in equipment or operation that can cause costly accelerated rope wear.

As with all of our inspections, the Amick inspector will review the inspection with a customer representative before leaving the premises to discuss corrective action or procedures.

### About the Repairs

Amick can revise and recertify your fittings on your wire rope bridle slings. High strength wire rope used to make your sling lift stronger and safer. All repaired slings tagged, tested and certified as per OSWA and ANSI regulations.

## Magnetic Particle Inspections

As one of our many professional inspections, the magnetic particle inspection has become an integral part of Amick's service and safety program.

Our NDE-trained inspector is qualified to perform magnetic particle inspections of our customer's crane hooks and spreader beam hooks.

We use the most up-to-date magnaflux equipment. The AX-DC magnaflux 1/2 wave P-70 unit coupled with a Magnetic Parker Probe Yoke will find any cracks, both surface and subsurface to 1/8-inch.

Amick Associates also offers ultrasound and Burdon Block inspections.

## On-Site Hoist Inspections and Repairs

### About the Inspection

- Our experienced staff can test all makes and models of hoists.
- A customer representative may join the inspection if he/she wishes to do so, however, it is not required.
- Any hoist failing inspection will be danger tagged and taken out of service immediately. Hoists passing inspection will be noted with a dated inspection sticker.
- Before leaving the customer's premises, the Amick hoist inspector will review the inspection with a customer representative to discuss corrective action or procedures.
- A complete, written inspection report will be sent to the customer one week after the inspection detailing the condition of every hoist inspected.

### About the Repairs

- Hoists danger tagged will be brought back to Amick Associates' hoist repair center. We are capable of repairing and/or replacing many brands of hoists and fittings with a minimal turnaround time.
- Customers will receive a 'new vs. repair' quote before any corrective action is taken.

## Warnings\*

### Warnings\*

1

#### Alloy Steel Chain Slings



- Chain sling **FAILURE** can cause **DEATH OR INJURY**.
- Sling failure results from misuse, damage, and excessive wear.
- Do not exceed working load limit.
- Use only alloy chain and attachments for overhead lifting.

#### Wire Rope



- Wire rope **WILL FAIL** if worn-out, overloaded, misused, damaged, improperly maintained or abused.
- Wire rope **FAILURE** may cause serious **INJURY OR DEATH**.
- Protect yourself and others:
  - ALWAYS INSPECT wire rope for WEAR, DAMAGE or ABUSE BEFORE USE.
  - NEVER USE wire rope that is WORN-OUT, DAMAGED or ABUSED.
  - NEVER OVERLOAD a wire rope.
  - INFORM YOURSELF: Read and understand manufacturer's literature or "Wire Rope and Wire Rope Sling Safety Bulletin."
  - REFER TO APPLICABLE CODES, STANDARDS and REGULATIONS for INSPECTION REQUIREMENTS and REMOVAL CRITERIA.

**Note:** For additional information or the BULLETIN, ask your employer or wire rope supplier.

#### Inspection, Care and Use of Synthetic Web Tiedowns

##### Removal From Service

A tiedown shall be removed from service if any of the following are visible:

1. Holes, tears, cuts, snags or embedded particles in the webbing.
2. Broken or worn stitching in load bearing stitch patterns.
3. Excessive abrasive wear of the webbing.
4. Knots in any part of the webbing.
5. Distortion, excessive pitting, corrosion or damage of any fitting or component.
6. Melting, charring, or weld spatter on any part of the webbing.
7. Chemical burns.
8. Any conditions that cause doubt as to the strength of the tiedown.

#### Inspection, Care and Use of Synthetic Polyester Roundslings

##### Removal From Service

A roundsling shall be removed from service if any of the following are visible:

1. If roundsling rated capacity tag is missing or not readable.
2. Acid or alkali burns on the roundsling.
3. Melting, charring or weld splatter of any part of the roundsling.
4. Holes, tears, cuts, snags, embedded particles or abrasive wear that expose the core fibers.
5. Broken or worn stitching in the cover that exposes the core fibers.
6. Knots in any part of the roundsling.
7. Distortion, excessive pitting, corrosion or broken fitting(s).
8. Any conditions that cause doubt as to the strength of the roundsling.

#### Inspection and Care of Synthetic Web Slings

Prior to use, make certain that each sling meets the requirements of your Purchase Order and that it has not been damaged in shipment.

##### Inspection

Remove slings from service if damage such as the following is visible:

1. Cuts on face or at edge of webbing.
2. Holes, tears, snags or crushed web.
3. Excessive abrasive wear.
4. Excessive pitting or corrosion, cracked, distorted or broken fittings.
5. Broken or worn threads in the stitch patterns.
6. Melting or charring of any part of the sling.
7. Acid or caustic burns.
8. Other visible damage that causes doubt as to the strength of the sling.

Failure to follow the care, use and inspection instructions could result in severe personal injury. Do not exceed rated capacities.

##### Operating Practices

Web slings can be cut by contact with sharp or unprotected load edges. Padding must be used to protect the slings.

#### Amick Nylon and Polyester Slings

##### Disclaimer of Warranties and Limitation of Liability

Seller warrants that its goods are free from defects in materials and workmanship. Accordingly, Seller's liability is limited to replacing without charge or refunding the purchase price, or making fair allowance for any noncompliance with any specifications or any defects in materials or workmanship in its products existing at the time of delivery. Seller requires written notice and the return of the product to establish any claim. SELLER MAKES NO OTHER WARRANTY OF ANY KIND WHATSOEVER, EXPRESSED OR IMPLIED, AND ALL IMPLIED WARRANTIES OF MERCHANTABILITY OR FITNESS FOR A PARTICULAR PURPOSE WHICH EXCEED THE ABOVE OBLIGATION ARE HEREBY DISCLAIMED BY SELLER AND EXCLUDED. Seller will not be liable for any consequential damages, loss or expense arising in connection with the use or inability whatsoever, regardless of whether damage, loss, or expense results from any act or failure to act by Seller, whether negligent or willful, or from any other reason.

### \*WARNING

Failure to comply with warnings may result in personal injury or death. See above.

# CHAIN

## Chain Slings

- General Information
- CM Chain Slings — Grade 80 & 100
- CM Bail-Type Magnet Chain Assemblies
- CM Standard Triple Branch Magnet Chains

## Hooks

- CM Hooks — Grade 80 & 100

## Links

- CM Master Links — Grade 80 & 100
- Stirrup Hooks

## Accessories

- CM Hammerlok Coupling Links
- CM S Hooks
- CM Plate Hooks
- CM Chain Shorteners
- CM Hook Latch Kits

## Welded Chain & Assemblies

- CM Binder Chain Assemblies
- CM Coil Chain
- CM Machine Chain
- CM Adjust-A-Link Sling

## Carbon Chain

- CM Grade 30, 43 & 70 Carbon Chain

## Inspections & Repairs

## Chain Slings

### Care, Use and Inspection

Ultimately, the life and strength of CM Herc-Alloy 800 chain slings depend on those who inspect, maintain and use it properly. For additional information on care, use and inspection, refer to ANSI B30.9 and OSHA regulations.

#### Care

Chain requires only minimum maintenance.

1. Store chains on an A-frame in a clean, dry place.
2. Oil chains before prolonged storage.
3. Never anneal Herc-Alloy 800 chain.
4. Hot galvanizing of Herc-Alloy 800 chain should not be attempted by anyone except under the direct supervision of the chain manufacturer.

#### Use

Observing these simple precautions when using chain slings can help protect both people and materials.

1. Free all twists, knots or kinks.
2. Center load on hook.
3. Avoid sudden jerks when lowering or lifting.
4. Balance all loads.
5. Never overload.
6. Use pads around sharp corners.
7. Don't drop loads on chain.

#### Inspection

It is important to inspect chain slings regularly and to keep a record of individual chain inspection. The following is a suggestion for such an inspection system.

Before inspecting: clean the chains so that marks, nicks, wear and other defects can be seen.

Each link should be inspected for the following danger signs:

1. Twists or bends.
2. Nicks or gouges.
3. Excessive wear at bearing points.
4. Stretch.
5. Distorted or damaged master links, coupling links, or attachments, especially spread in throat opening of hooks.

Each link or attachment having any defect listed above should be marked with paint to plainly indicate rejection and elimination from service until properly repaired.

### Wear Allowance (Herc-Alloy 800 Chain)

Determine wear by measuring cross section at link ends. If worn to less than the minimum thickness allowable, chain should be removed from service.

**Table 2-1. Wear Allowance**

Chain Size		Maximum Allowable Wear (in.)	Minimum Thickness Allowable at Link Ends (in.) <sup>①</sup>
(in.)	(mm)		
7/32	5.5	—	11/64 (.171)
9/32	7.0	3/64 (.046)	13/64 (.203)
3/8	10.0	5/64 (.078)	18/64 (.281)
1/2	13.0	7/64 (.109)	22/64 (.343)
5/8	16.0	9/64 (.140)	27/64 (.421)
3/4	20.0	10/64 (.156)	34/64 (.531)
7/8	22.0	11/64 (.171)	40/64 (.625)
1	26.0	12/64 (.187)	47/64 (.734)
1-1/4	32.0	16/64 (.250)	58/64 (.906)

<sup>①</sup> Applies to Herc-Alloy 800 chain only.

### CM Chain Inspection Programs

CM Chain provides users with a wide range of informative materials and instructive programs on chain and chain inspection.

A colorful chain safety poster/chart, and a fact-filled booklet, "Inspecting Chain Slings," are both available upon request.

CM Chain Clinics on proper chain use, care and inspection are held at company headquarters and in plants across the country. Also available are video cassette training programs, slide and film presentations, and in-plant chain sling inspections.

CM Chain's education programs are designed to promote the proper use of all CM products, and to assist users in complying with OSHA regulations.

### OSHA and CM Grade 80

OSHA regulations are not intended to inhibit technological progress. The use of chains and chain attachments at higher working load ratings than specified in ANSI B30.9 is permitted by OSHA if they substantially exceed the strength requirements described in B30.9. In such instances they may be used at ratings recommended by the manufacturer. Herc-Alloy 800 chain and accessories meet these requirements and may be used at the working load limits published in this catalog.

### Use of Chain Under Heat Conditions

When the chain itself is heated to temperatures shown below, the Working Load Limits should be reduced as indicated.

**Table 2-2. Working Load Limit Under Heat Conditions**

Chain Temperature (°F)	Reduction in Working Load Limit While Heated <sup>①</sup>	Permanent Reduction in Working Load Limit <sup>②</sup>
500	none	none
600	10%	none
700	20%	none
800	30%	none
900	40%	10%
1000	50%	15%

<sup>①</sup> While chain is at temperature shown in first column.

<sup>②</sup> When chain is used at room temperature after having been heated to temperatures shown in first column.

### Certificate of Test and Identification

The Identification Tag is found on the master coupling link of each chain sling and contains the following information:

- Grade
- Size
- Reach
- Type
- Working load limit (at a specific angle of lift)
- Serial number

A Certificate of Test is provided for every Columbus McKinnon made chain sling. The CM certificate has all of the information provided on the identification tag, and also gives the Proof Test load as required by OSHA regulations.

### Other Herc-Alloy 800 Specialties

CM's flat die forge shop is equipped to produce special chain sling attachments from your drawings. Die pins, special shackles, eye-bolts, stirrup hooks and many other fittings required to meet unusual conditions can be made to order.

### Herc-Alloy Welded Chain Slings

Made in the U.S.A. 

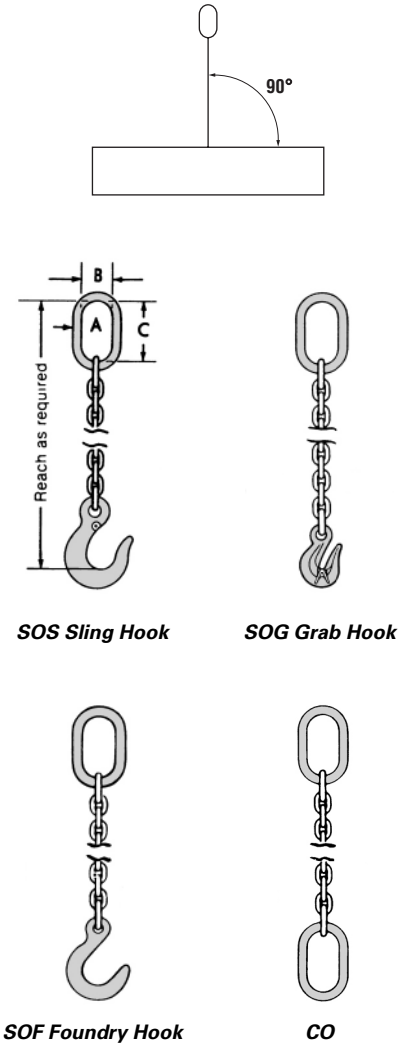
### CM Single Chain Sling Types S & C

Table 2-3. Grade 80 CM Herc Alloy 800

Chain Size		Working Load Limit (lbs.)*	Oblong Master Link			Approx. Weight (lbs.)
(in.)	(mm)		Dimensions (inches)			
			Diameter Material A	Inside Width B	Inside Length C	Type SOS 5' Reach
7/32	5.5	2,100	13/32	1-1/2	3	4
9/32	7	3,500	1/2	2-1/2	5	5
3/8	10	7,100	3/4	2-3/4	5-1/2	10
1/2	13	12,000	1	3-1/2	7	18
5/8	16	18,100	1	3-1/2	7	25
3/4	20	28,300	1-1/4	4-3/8	8-3/4	38
7/8	22	34,200	1-1/2	5-1/4	10-1/2	54
1	26	47,700	1-3/4	6	12	76
1-1/4	32	72,300	2	7	14	116

Table 2-4. Grade 100 CM Herc Alloy 1000

Chain Size		Working Load Limit (lbs.)*	Oblong Master Link			Approx. Weight (lbs.)
(in.)	(mm)		Dimensions (inches)			
			Diameter Material A	Inside Width B	Inside Length C	Type SOS 5' Reach
7/32	5.5	2,700	13/32	1-1/2	3	4
9/32	7	4,300	1/2	2-1/2	5	5
3/8	10	8,800	3/4	2-3/4	5-1/2	10
1/2	13	15,000	1	3-1/2	7	18
5/8	16	22,600	1	3-1/2	7	25
3/4	20	35,300	1-1/4	4-3/8	8-3/4	38



2

**\*WARNING** Do not exceed working load limits. — Use only alloy chain and attachments for lifting.

# CHAIN

Amick Associates, Inc.

## Chain Slings

version #2-04

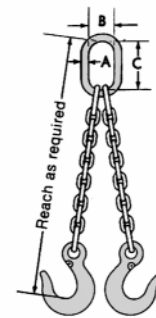
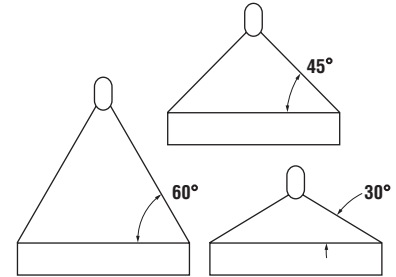
### Herc-Alloy Welded Chain Slings

Made in the U.S.A.

#### CM Double Chain Sling Type D

Table 2-5. Grade 80 CM Herc Alloy 800

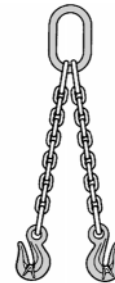
Chain Size		Working Load Limit (lbs.)*			Oblong Master Link Dimensions (inches)			Approx. Weight (lbs.)
(in.)	(mm)	60°	45°	30°	Diameter Material A	Inside Width B	Inside Length C	Type DOS 5' Reach
7/32	5.5	3,600	3,000	2,100	13/32	1-1/2	3	8
9/32	7	6,100	4,900	3,500	1/2	2-1/2	5	9
3/8	10	12,300	10,000	7,100	3/4	2-3/4	5-1/2	18
1/2	13	20,800	17,000	12,000	1	3-1/2	7	31
5/8	16	31,300	25,600	18,100	1-1/4	4-3/8	8-3/4	49
3/4	20	49,000	40,000	28,300	1-1/2	5-1/4	10-1/2	71
7/8	22	59,200	48,400	34,200	1-3/4	6	12	98
1	26	82,600	67,400	47,700	2	7	14	132
1-1/4	32	125,200	102,200	72,300	2-1/4	8	16	221



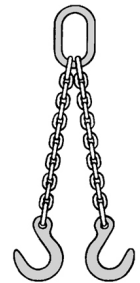
DOS Sling Hooks

Table 2-6. Grade 100 CM Herc Alloy 1000

Chain Size		Working Load Limit (lbs.)*			Oblong Master Link Dimensions (inches)			Approx. Weight (lbs.)
(in.)	(mm)	60°	45°	30°	Diameter Material A	Inside Width B	Inside Length C	Type DOS 5' Reach
7/32	5.5	4,700	3,800	2,700	13/32	1-1/2	3	8
9/32	7	7,400	6,100	4,300	1/2	2-1/2	5	9
3/8	10	15,200	12,400	8,800	3/4	2-3/4	5-1/2	18
1/2	13	26,000	21,200	15,000	1	3-1/2	7	31
5/8	16	39,100	32,000	22,600	1-1/4	4-3/8	8-3/4	49
3/4	20	61,100	49,900	35,300	1-1/2	5-1/4	10-1/2	71



DOG Grab Hooks



DOF Foundry Hooks

### \*WARNING

Do not exceed working load limits. — Use only alloy chain and attachments for lifting.

### Herc-Alloy Welded Chain Slings

Made in the U.S.A. 

#### CM Triple & Quad Chain Sling Type T & Q

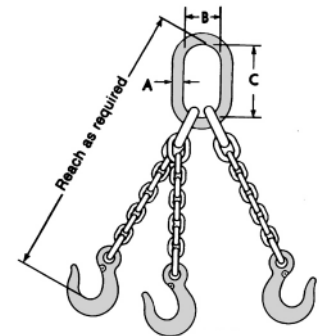
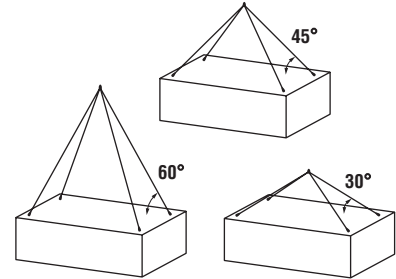
**Safety note:** A quad branch chain sling usually does not sustain loads with even distribution to its four branches, especially when loads are of rigid structure. Therefore, maximum working load limits are set at the same values as for triple branch chain slings of equal quality and size and used with branches at the same angle of inclination.

**Table 2-7. Grade 80 CM Herc Alloy 800**

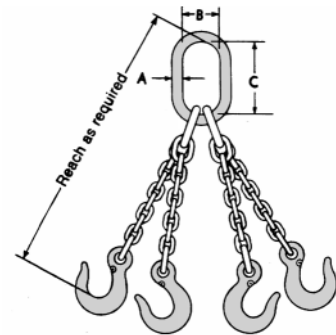
Chain Size		Working Load Limit (lbs.)*			Oblong Master Link Sub-Assembly Dimensions (inches)			Approx. Weight (lbs.)	
(in.)	(mm)	60°	45°	30°	Diameter Material A	Inside Width B	Inside Length C	Type TOS 5' Reach	Type QOS 5' Reach
7/32	5.5	5,450	4,450	3,150	1/2	2-1/2	5	12	16
9/32	7	9,100	7,400	5,200	3/4	2-3/4	5-1/2	14	18
3/8	10	18,400	15,100	10,600	1	3-1/2	7	28	36
1/2	13	31,200	25,500	18,000	1-1/4	4-3/8	8-3/4	50	62
5/8	16	47,000	38,400	27,100	1-1/2	5-1/4	10-1/2	79	97
3/4	20	73,500	60,000	42,400	1-3/4	6	12	112	137
7/8	22	88,900	72,500	51,800	2	7	14	155	188
1	26	123,900	101,200	71,500	2-1/4	8	16	215	260
1-1/4	32	187,800	153,400	108,400	2-3/4	9	16	348	421

**Table 2-8. Grade 100 CM Herc Alloy 1000**

Chain Size		Working Load Limit (lbs.)*			Oblong Master Link Sub-Assembly Dimensions (inches)			Approx. Weight (lbs.)	
(in.)	(mm)	60°	45°	30°	Diameter Material A	Inside Width B	Inside Length C	Type TOS 5' Reach	Type QOS 5' Reach
7/32	5.5	7,000	5,700	4,000	1/2	2-1/2	5	12	16
9/32	7	11,200	9,100	6,400	3/4	2-3/4	5-1/2	14	18
3/8	10	22,900	18,700	13,200	1	3-1/2	7	28	36
1/2	13	39,000	31,800	22,500	1-1/4	4-3/8	8-3/4	50	62
5/8	16	58,700	47,900	33,900	1-1/2	5-1/4	10-1/2	79	97
3/4	20	91,700	74,900	53,000	1-3/4	6	12	112	137



TOS Sling Hooks



QOS Sling Hooks

**\*WARNING**

Do not exceed working load limits. — Use only alloy chain and attachments for lifting.

# CHAIN

Amick Associates, Inc.

## Chain Slings

version #2-04

### Herc-Alloy Welded Chain Slings

Made in the U.S.A. 

#### CM Adjustable Single Chain Sling

Style B single and double adjustable slings are furnished with approximately one (1) foot of chain in short branches unless otherwise specified in the order.

Table 2-9. Grade 80 CM Herc Alloy 800

Chain Size		Working Load Limit (lbs.)*	Oblong Master Link		
(in.)	(mm)		Dimensions (inches)		
			Diameter Material A	Inside Width B	Inside Length C
7/32	5.5	2,100	13/32	1-1/2	3
9/32	7	3,500	1/2	2-1/2	5
3/8	10	7,100	3/4	2-3/4	5-1/2
1/2	13	12,000	1	3-1/2	7
5/8	16	18,100	1	3-1/2	7
3/4	20	28,300	1-1/4	4-3/8	8-3/4
7/8	22	34,200	1-1/2	5-1/4	10-1/2
1	26	47,700	1-3/4	6	12
1-1/4	32	72,300	2	7	14

Table 2-10. Grade 100 CM Herc Alloy 1000

Chain Size		Working Load Limit (lbs.)*	Oblong Master Link		
(in.)	(mm)		Dimensions (inches)		
			Diameter Material A	Inside Width B	Inside Length C
7/32	5.5	2,700	13/32	1-1/2	3
9/32	7	4,300	1/2	2-1/2	5
3/8	10	8,800	3/4	2-3/4	5-1/2
1/2	13	15,000	1	3-1/2	7
5/8	16	22,600	1	3-1/2	7
3/4	20	35,300	1-1/4	4-3/8	8-3/4



Style A



Style B

#### \* WARNING

Do not exceed working load limits. — Use only alloy chain and attachments for lifting.

### Herc-Alloy Welded Chain Slings

Made in the U.S.A. 

#### CM Adjustable Double Chain Slings

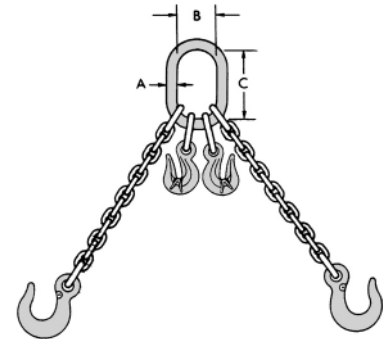
Style B single and double adjustable slings are furnished with approximately one (1) foot of chain in short branches unless otherwise specified in the order.

**Table 2-11. Grade 80 CM Herc Alloy 800**

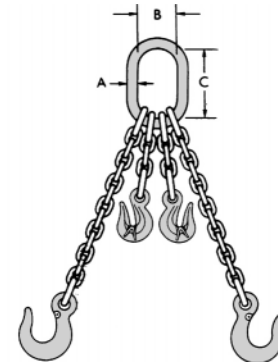
Chain Size		Working Load Limit (lbs.)*			Oblong Master Link		
(in.)	(mm)	60°	45°	30°	Dimensions (inches)		
					Diameter Material A	Inside Width B	Inside Length C
7/32	5.5	3,600	3,000	2,100	13/32	1-1/2	3
9/32	7	6,100	4,900	3,500	1/2	2-1/2	5
3/8	10	12,300	10,000	7,100	3/4	2-3/4	5-1/2
1/2	13	20,800	17,000	12,000	1	3-1/2	7
5/8	16	31,300	25,600	18,100	1-1/4	4-3/8	8-3/4
3/4	20	49,000	40,000	28,300	1-1/2	5-1/4	10-1/2
7/8	22	59,200	48,400	34,200	1-3/4	6	12
1	26	82,600	67,400	47,700	2	7	14
1-1/4	32	125,200	102,200	72,300	2-1/4	8	16

**Table 2-12. Grade 100 CM Herc Alloy 1000**

Chain Size		Working Load Limit (lbs.)*			Oblong Master Link		
(in.)	(mm)	60°	45°	30°	Dimensions (inches)		
					Diameter Material A	Inside Width B	Inside Length C
7/32	5.5	4,700	3,800	2,700	13/32	1-1/2	3
9/32	7	7,400	6,100	4,300	1/2	2-1/2	5
3/8	10	15,200	12,400	8,800	3/4	2-3/4	5-1/2
1/2	13	26,000	21,200	15,000	1	3-1/2	7
5/8	16	39,100	32,000	22,600	1-1/4	4-3/8	8-3/4
3/4	20	61,100	49,900	35,300	1-1/2	5-1/4	10



Style A



Style B

2

**\*WARNING**

Do not exceed working load limits. — Use only alloy chain and attachments for lifting.

# CHAIN

Amick Associates, Inc.

## Chain Slings

version #2-04

### Herc-Alloy Welded Chain Slings

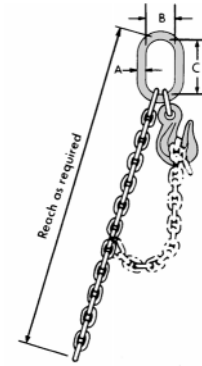
Made in the U.S.A. 

#### CM Adjustable Single Loop Chain Slings

Style B furnished with approximately one (1) foot of chain in short branches.

**Table 2-13. Grade 80 CM Herc Alloy 800**

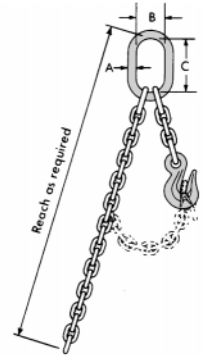
Chain Size		Working Load Limit (lbs.)*			Oblong Master Link		
(in.)	(mm)	60°	45°	30°	Dimensions (inches)		
					Diameter Material A	Inside Width B	Inside Length C
7/32	5.5	3,600	3,000	2,100	13/32	1-1/2	3
9/32	7	6,100	4,900	3,500	1/2	2-1/2	5
3/8	10	12,300	10,000	7,100	3/4	2-3/4	5-1/2
1/2	13	20,800	17,000	12,000	1	3-1/2	7
5/8	16	31,300	25,600	18,100	1-1/4	4-3/8	8-3/4
3/4	20	49,000	40,000	28,300	1-1/2	5-1/4	10-1/2
7/8	22	59,200	48,400	34,200	1-3/4	6	12
1	26	82,600	67,400	47,700	2	7	14
1-1/4	32	125,200	102,200	72,300	2-1/4	8	16



Style A

**Table 2-14. Grade 100 CM Herc Alloy 1000**

Chain Size		Working Load Limit (lbs.)*			Oblong Master Link		
(in.)	(mm)	60°	45°	30°	Dimensions (inches)		
					Diameter Material A	Inside Width B	Inside Length C
7/32	5.5	4,700	3,800	2,700	13/32	1-1/2	3
9/32	7	7,400	6,100	4,300	1/2	2-1/2	5
3/8	10	15,200	12,400	8,800	3/4	2-3/4	5-1/2
1/2	13	26,000	21,200	15,000	1	3-1/2	7
5/8	16	39,100	32,000	22,600	1-1/4	4-3/8	8-3/4
3/4	20	61,100	49,900	35,300	1-1/2	5-1/4	10



Style B

#### \* WARNING

Do not exceed working load limits. — Use only alloy chain and attachments for lifting.

### Herc-Alloy Welded Chain Slings

Made in the U.S.A. 

#### CM Adjustable Double Loop Chain Sling

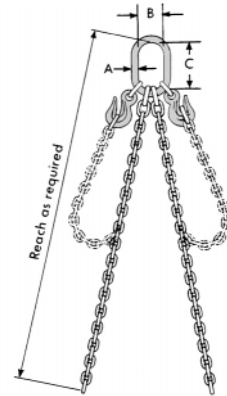
Style B furnished with approximately one (1) foot of chain in short branches.

**Table 2-15. Grade 80 CM Herc Alloy 800**

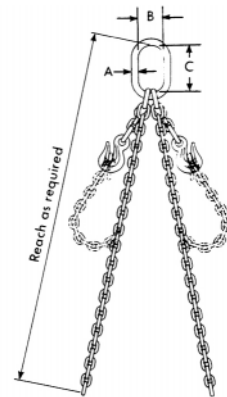
Chain Size		Working Load Limit (lbs.)*			Oblong Master Link Sub-Assembly		
(in.)	(mm)	60°	45°	30°	Dimensions (inches)		
					Diameter Material A	Inside Width B	Inside Length C
7/32	5.5	5,450	4,450	3,150	1/2	2-1/2	5
9/32	7	9,100	7,400	5,200	3/4	2-3/4	5-1/2
3/8	10	18,400	15,100	10,600	1	3-1/2	7
1/2	13	31,200	25,500	18,000	1-1/4	4-3/8	8-3/4
5/8	16	47,000	38,400	27,100	1-1/2	5-1/4	10-1/2
3/4	20	73,500	60,000	42,400	1-3/4	6	12
7/8	22	88,900	72,500	51,300	2	7	14
1	26	123,900	101,200	71,500	2-1/4	8	16
1-1/4	32	187,800	153,400	108,400	2-3/4	9	16

**Table 2-16. Grade 100 CM Herc Alloy 1000**

Chain Size		Working Load Limit (lbs.)*			Oblong Master Link Sub-Assembly		
(in.)	(mm)	60°	45°	30°	Dimensions (inches)		
					Diameter Material A	Inside Width B	Inside Length C
7/32	5.5	7,000	5,700	4,000	1/2	2-1/2	5
9/32	7	11,200	9,100	6,400	3/4	2-3/4	5-1/2
3/8	10	22,900	18,700	13,200	1	3-1/2	7
1/2	13	39,000	31,800	22,500	1-1/4	4-3/8	8-3/4
5/8	16	58,700	47,900	33,900	1-1/2	5-1/4	10-1/2
3/4	20	91,700	74,900	53,000	2-3/4	6	12



Style A



Style B

**\*WARNING**

Do not exceed working load limits. — Use only alloy chain and attachments for lifting.

# CHAIN

Amick Associates, Inc.

## Chain Slings

version #2-04

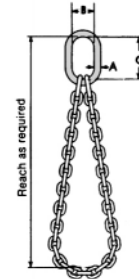
### Herc-Alloy Welded Chain Slings

Made in the U.S.A. 

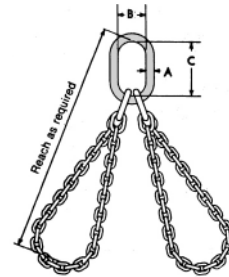
#### CM Basket Type Chain Sling (Single and Double)

Table 2-17. Grade 80 CM Herc Alloy 800

Chain Size		Working Load Limit (lbs.)*		Oblong Master Link					
		60°		Single Basket			Double Basket		
(in.)	(mm)	Single	Double	Diameter Material A	Inside Width B	Inside Length C	Diameter Material A	Inside Width B	Inside Length C
7/32	5.5	3,600	5,450	13/32	1-1/2	3	1/2	2-1/2	5
9/32	7	6,100	9,100	1/2	2-1/2	5	3/4	2-3/4	5-1/2
3/8	10	12,300	18,400	3/4	2-3/4	5-1/2	1	3-1/2	7
1/2	13	20,800	31,200	1	3-1/2	7	1-1/4	4-3/8	8-3/4
5/8	16	31,300	47,000	1-1/4	4-3/8	8-3/4	1-1/2	5-1/4	10-1/2
3/4	20	49,000	73,500	1-1/2	5-1/4	10-1/2	1-3/4	6	12
7/8	22	59,200	88,900	1-3/4	6	12	2	7	14
1	26	82,600	123,900	2	7	14	2-1/4	8	16
1-1/4	32	125,200	187,800	2-1/4	8	16	2-3/4	9	16



Single Basket Type



Double Basket Type

Table 2-18. Grade 100 CM Herc Alloy 1000

Chain Size		Working Load Limit (lbs.)*		Oblong Master Link					
		60°		Single Basket			Double Basket		
(in.)	(mm)	Single	Double	Diameter Material A	Inside Width B	Inside Length C	Diameter Material A	Inside Width B	Inside Length C
7/32	5.5	4,700	7,000	13/32	1-1/2	3	1/2	2-1/2	5
9/32	7	7,400	11,200	1/2	2-1/2	5	3/4	2-3/4	5-1/2
3/8	10	15,200	22,900	3/4	2-3/4	5-1/2	1	3-1/2	7
1/2	13	26,000	39,000	1	3-1/2	7	1-1/4	4-3/8	8-3/4
5/8	16	39,100	58,700	1-1/4	4-3/8	8-3/4	1-1/2	5-1/4	10-1/2
3/4	20	61,100	91,700	1-1/2	5-1/4	10	1-3/4	6	12

#### \* WARNING

Do not exceed working load limits. — Use only alloy chain and attachments for lifting.

### Herc-Alloy Welded Chain Slings

Made in the U.S.A. 

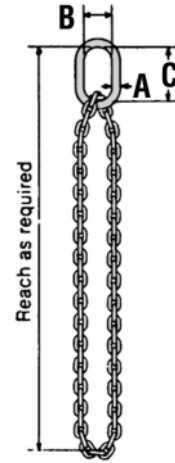
### CM Endless Basket Chain Sling (Single and Double)

**Table 2-19. Grade 80 CM Herc Alloy 800**

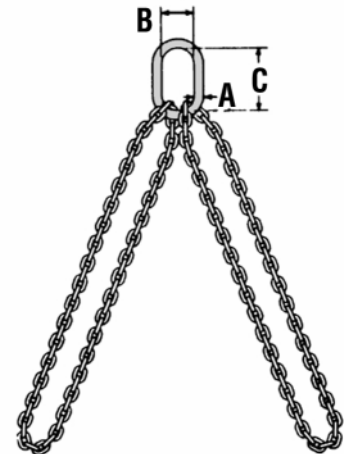
Chain Size		Working Load Limit (lbs.)*		Oblong Master Link					
		90°		Single Basket			Double Basket		
(in.)	(mm)	Single	Double	Diameter Material A	Inside Width B	Inside Length C	Diameter Material A	Inside Width B	Inside Length C
7/32	5.5	2,100	3,600	15/32	1-1/2	3	1/2	2-1/2	5
9/32	7	3,500	6,100	1/2	2-1/2	5	3/4	2-3/4	5-1/2
3/8	10	7,100	12,300	3/4	2-3/4	5-1/2	1	3-1/2	7
1/2	13	12,000	20,800	1	3-1/2	7	1-1/4	4-3/8	8-3/4
5/8	16	18,100	31,300	1-1/4	4-3/8	8-3/4	1-1/2	5-1/4	10-1/2
3/4	20	28,300	49,000	1-1/2	5-1/4	10-1/2	1-3/4	6	12
7/8	22	34,200	59,200	1-3/4	6	12	2	7	14

**Table 2-20. Grade 100 CM Herc Alloy 1000**

Chain Size		Working Load Limit (lbs.)*		Oblong Master Link					
		90°		Single Basket			Double Basket		
(in.)	(mm)	Single	Double	Diameter Material A	Inside Width B	Inside Length C	Diameter Material A	Inside Width B	Inside Length C
7/32	5.5	2,700	4,700	13/32	1-1/2	3	1/2	2-1/2	5
9/32	7	4,300	7,400	1/2	2-1/2	5	3/4	2-3/4	5-1/2
3/8	10	8,800	15,200	3/4	2-3/4	5-1/2	1	3-1/2	7
1/2	13	15,000	26,000	1	3-1/2	7	1-1/4	4-3/8	8-3/4
5/8	16	22,600	31,900	1-1/4	4-3/8	8-3/4	1-1/2	5-1/4	10-1/2
3/4	20	35,300	61,100	1-1/2	5-1/4	10-1/2	1-3/4	6	12



Single Endless Basket



Double Endless Basket

2

**\*WARNING**

Do not exceed working load limits. — Use only alloy chain and attachments for lifting.

# CHAIN

Amick Associates, Inc.

## Chain Slings

version #2-04

### Herc-Alloy Welded Chain Slings

Made in the U.S.A. 

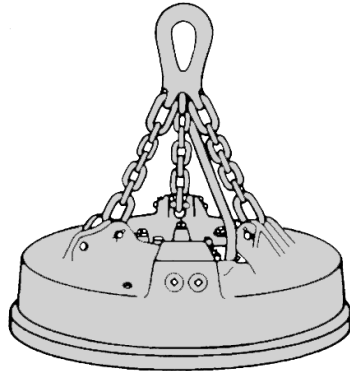
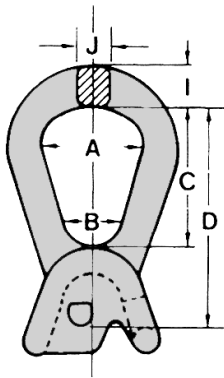
#### CM Bail-Type Magnet Chain Assemblies

- An alloy casting supplied with welded links and chain.
- Magnet not included with assembly.

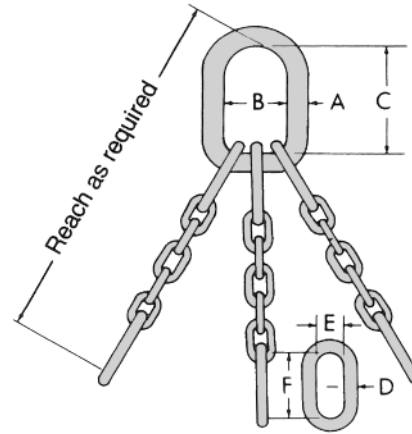
#### CM Standard Triple Branch Magnet Chains

- Assembled with 5 links of body chain in each branch.

2



CM Bail-Type Magnet Chain Assemblies



CM Standard Triple Branch Magnet Chains

Table 2-21. CM Bail-Type Magnet Chain Assemblies

Chain Size (in.)	Product Code	UPC 43927-	Magnet Diameter (in.)	Assembly Working Load Limit (lbs.)*	Bail (in.)						End Link (in.)			Standard Reach (in.) <sup>①</sup>	Length of 2 Body Chain Links (in.) <sup>①</sup>	Assembly Weight (lbs.)
					A	B	C	D	I	J	Dia. A	Inside Width B	Inside Length C			
3/4	607442	20932	39 to 44	59,500	4-1/4	3	7	11-1/4	2	2	7/8	2	5	31-1/4	4	69.4
7/8	607443	22535	44 & 45	74,500	4-1/4	3	7	11-1/4	2	2	1	2-1/4	5-3/4	34	4-1/2	83.8
1	607444	20933	45 & 60	101,000	5-3/16	3-1/2	8	12-3/4	2-3/8	2-1/4	1-1/8	2-1/4	5-3/4	37-9/16	5-9/16	125.9
1-1/4	607445	22785	over 60	149,000	7-1/2	6	11	17	2-1/2	2-1/2	1-1/2	3-1/8	8	49-1/4	6-1/2	265.5

① If additional reach is required, add 2 link increments to standard total reach.

Table 2-22. CM Bail-Type Magnet Chain Assemblies

Chain Size (in.)	Working Load Limit (lbs.)*	Product Code	UPC 43927-	Magnet Diameter (in.)	Master Link (in.)			End Link (in.)			Standard Reach (in.) <sup>①</sup>	Approximate Weight (lbs.)	Length of 2 Body Chain Links (in.)
					Diameter A	Inside Width B	Inside Length C	Diameter D	Inside Width E	Inside Length F			
5/8	47,000	604701	20927	up to 39	1-3/4	5	8	3/4	2	5	26-3/4	40	3-1/2
3/4	73,500	604702	20928	39 to 44	1-3/4	5	8	7/8	2	5	28	49	4
7/8	88,900	604703	20929	44 & 45	2	5	9	1	2-1/4	5-3/4	31-3/4	72	4-1/2
1	123,900	604704	20930	45 to 60	2	5	9	1-1/8	2-1/4	5-3/4	33-13/16	91-1/2	5-3/8
1-1/4	187,800	604705	20931	over 60	2-1/2	6-1/2	12	1-1/2	3-1/8	8	44-1/4	193-1/2	6-1/2

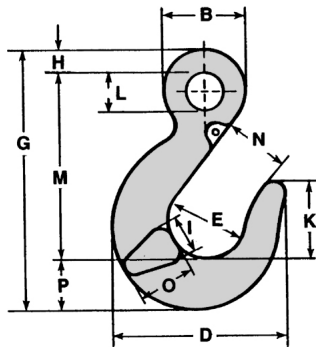
① If additional reach is required, add 2 link increments to standard total reach.

### \* ⚠ WARNING

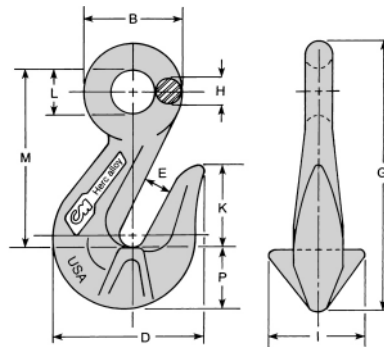
Do not exceed working load limits. — Use only alloy chain and attachments for lifting.

### Hooks

#### CM Sling Hook<sup>①</sup> without Latch — 100% Proof Tested



#### CM Cradle Grab Hook — 100% Proof Tested



2

**Table 2-23. CM Sling Hook<sup>①</sup> without Latch — 100% Proof Tested**

Chain Size		Grade 80 Working Load Limit (lbs.)*	Grade 100 Working Load Limit (lbs.)*	Dimensions (inches)												Weight Each (lbs.)
(in.)	(mm)			B	D	E	G	H	I	K	L	M	N	O	P	
7/32	5.5	2,100	2,700	—	3.31	1.44	4.30	.38	.78	1.25	.75	3.06	1.25	1.00	.86	.70
9/32	7	3,500	5,700	1.62	3.50	1.50	5.25	.44	.73	1.59	.75	3.75	1.19	1.20	1.05	1.10
3/8	10	7,100	8,800	2.06	4.34	1.88	6.64	.56	.95	2.19	.94	4.78	1.44	1.45	1.28	1.90
1/2	13	12,000	15,000	2.63	5.50	2.25	8.16	.75	1.17	2.56	1.13	5.69	1.78	1.94	1.66	4.50
5/8	16	18,100	22,600	3.06	6.34	2.63	9.66	.88	1.44	2.63	1.31	6.50	2.03	2.38	2.19	7.30
3/4	20	28,300	35,300	3.50	7.83	3.00	11.38	1.00	1.69	3.44	1.50	7.81	2.50	2.83	2.51	11.40
7/8	22	34,200	N/A	3.88	8.59	3.38	12.72	1.09	1.94	3.88	1.69	8.75	2.78	3.22	2.84	18.10
1	26	47,700	N/A	4.31	9.59	4.00	14.23	1.22	2.14	4.25	1.88	9.88	3.13	3.55	3.09	22.60
1-1/4	32	72,300	N/A	5.31	11.56	4.66	17.00	1.50	2.62	4.64	2.31	11.50	3.88	4.25	3.89	36.00

<sup>①</sup> Available from stock with/without latch. Replacement latch kits are also available.

**Table 2-24. CM Cradle Grab Hook — 100% Proof Tested**

Chain Size		Grade 80 Working Load Limit (lbs.)*	Grade 100 Working Load Limit (lbs.)*	Dimensions (inches)											Weight Each (lbs.)
(in.)	(mm)			B	D	E	G	H	I	K	L	M	P		
7/32	5.5	2,100	2,700	1.19	1.75	.36	2.69	.38	1.19	.96	.63	1.63	.70	.35	
9/32	7	3,500	4,300	1.38	1.81	.36	3.44	.38	1.19	.99	.63	2.36	.70	.40	
3/8	10	7,100	8,800	1.78	2.63	.45	4.67	.50	1.75	1.48	.78	3.11	1.06	1.06	
1/2	13	12,000	15,000	2.28	3.34	.59	5.86	.63	1.88	1.98	1.03	3.94	1.30	2.26	
5/8	16	18,100	22,600	2.75	4.08	.75	7.13	.75	2.25	2.63	1.25	4.78	1.59	4.36	
3/4	20	28,300	35,300	3.19	5.23	.88	8.99	.88	2.88	3.50	1.44	6.25	1.88	8.82	
7/8	22	34,200	N/A	3.75	5.69	1.00	9.63	1.00	3.00	3.75	1.75	6.50	2.12	10.40	
1	26	47,700	N/A	4.31	7.00	1.19	12.44	1.22	3.88	4.31	1.88	8.09	3.12	20.90	
1-1/4 <sup>①</sup>	32	72,300	N/A	5.38	8.50	1.50	15.56	1.56	3.50	5.50	2.25	10.50	3.50	40.00	

<sup>①</sup> Not cradle type.

**\* ⚠ WARNING** Do not exceed working load limits. — Use only alloy chain and attachments for lifting.

# CHAIN

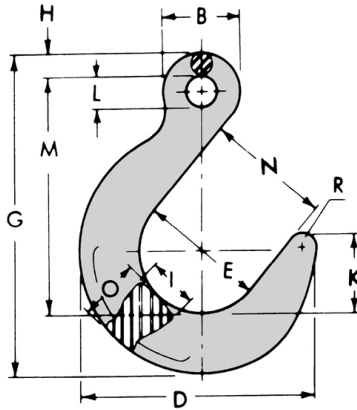
Amick Associates, Inc.

## Hooks

version #2-04

Made in the U.S.A. 

### CM Foundry Hook — 100% Proof Tested



### CM Large Eye Latchlok Hook — 100% Proof Tested

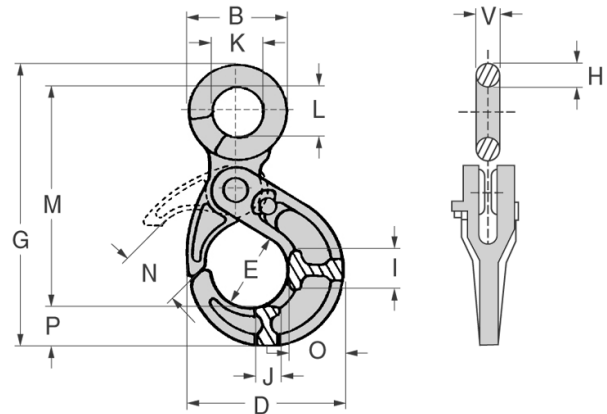


Table 2-25. CM Foundry Hook — 100% Proof Tested

Chain Size		Grade 80 Working Load Limit (lbs.)*	Grade 100 Working Load Limit (lbs.)*	Dimensions (inches)													Weight Each (lbs.)
(in.)	(mm)			B	D	E	G	H	I	K	L	M	N	O	R		
9/32	7	3,500	5,700	1.56	4.75	2.50	6.45	.47	1.00	1.56	.63	4.75	2.50	1.23	.25	2.40	
3/8	10	7,100	8,800	2.00	5.75	3.00	7.88	.63	1.27	1.88	.75	5.75	3.00	1.50	.31	4.50	
1/2	13	12,000	15,000	2.50	6.75	3.50	9.38	.75	1.50	2.22	1.00	6.88	3.50	1.75	.37	7.10	
5/8	16	18,100	22,600	3.00	7.81	4.00	10.97	.88	1.81	2.63	1.25	8.06	4.00	2.03	.43	11.60	
3/4	20	28,300	35,300	3.50	9.13	4.50	12.81	1.00	2.20	3.00	1.50	9.25	4.50	2.56	.50	20.00	
7/8	22	34,200	N/A	4.00	10.14	5.00	14.23	1.13	2.25	3.38	1.75	10.38	5.00	2.78	.56	26.00	
1	26	47,700	N/A	4.50	11.13	5.50	15.84	1.25	2.59	3.75	2.13	11.56	5.50	3.03	.62	36.80	
1-1/4	32	72,300	N/A	5.13	12.84	6.00	18.03	1.38	3.17	4.25	2.38	12.88	6.00	3.81	.75	58.40	

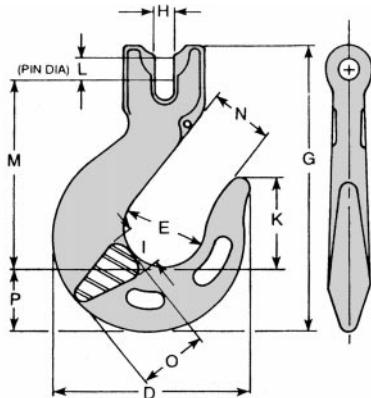
Table 2-26. CM Large Eye Latchlok Hook — 100% Proof Tested

Chain Size		Grade 80 Working Load Limit (lbs.)*	Grade 100 Working Load Limit (lbs.)*	Dimensions (inches)																Weight Each (lbs.)
(in.)	(mm)			B	D	E	G	H	I	J	K	L	M	N	O	P	V			
9/32	7	3,500	N/A	2-3/16	3-7/16	1-3/8	6-11/16	1/2	15/16	13/16	1-3/16	1-3/16	5-3/16	1-3/8	1-5/16	1	1/2	1.28		
3/8	10	7,100	N/A	2-13/16	4-1/16	1-3/4	8-11/32	11/16	1-1/8	5/8	1-7/16	1-7/16	6-1/2	1-3/4	1-19/32	1-9/64	11/16	2.08		
1/2	13	12,000	N/A	3-5/8	4-3/4	2-1/4	10-9/16	7/8	1-11/16	1-3/8	1-7/8	1-7/8	8-9/32	2-3/16	1-21/32	1-3/8	7/8	4.12		
5/8-3/4	16/20	28,300	N/A	5-1/16	5-3/4	2-7/16	13-1/2	1-1/4	2-1/16	1-3/4	2-9/16	2-9/16	10-1/2	2-5/8	2-3/8	1-3/4	1-1/4	10.34		

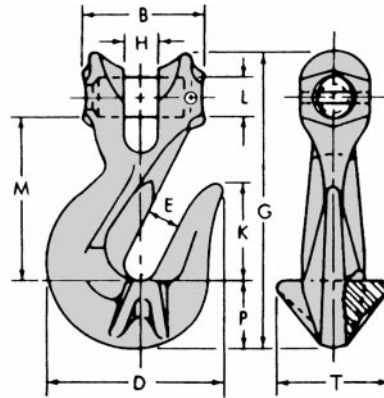
### \*WARNING

Do not exceed working load limits. — Use only alloy chain and attachments for lifting.

### CM Clevlok Sling Hook<sup>①</sup> without Latch — 100% Proof Tested



### CM Clevlok Cradle Grab Hook — 100% Proof Tested



2

**Table 2-27. CM Clevlok Sling Hook<sup>①</sup> without Latch — 100% Proof Tested**

Chain Size		Grade 80 Working Load Limit (lbs.)*	Grade 100 Working Load Limit (lbs.)*	Dimensions (inches)											Weight Each (lbs.)
(in.)	(mm)			D	E	G	H	I	K	L	M	N	O	P	
9/32	7	3,500	N/A	3.500	1.500	5.156	.328	.734	1.594	.357	3.437	1.187	1.203	1.051	.64
3/8	10	7,100	N/A	4.343	1.875	6.672	.453	.953	2.187	.507	4.468	1.437	1.453	1.281	1.91
1/2	13	12,000	N/A	5.500	2.250	8.000	.593	1.172	2.562	.625	5.265	1.781	1.938	1.656	4.33
5/8	16	18,100	N/A	6.281	2.625	9.687	.750	1.438	2.281	.750	6.078	2.031	2.375	2.188	5.20
3/4	20	28,300	N/A	7.827	3.000	11.688	.875	1.688	3.437	.906	7.344	2.500	2.828	2.563	11.40

<sup>①</sup> Latches available either as an option or in kit form. Replacement load pins and retainer pins available.

**Table 2-28. CM Clevlok Cradle Grab Hook — 100% Proof Tested**

Chain Size		Grade 80 Working Load Limit (lbs.)*	Grade 100 Working Load Limit (lbs.)*	Dimensions (inches)											Weight Each (lbs.)
(in.)	(mm)			B	D	E		G	H	K	L	M	P	T	
		Dim.	Tol.												
9/32	7	3,500	N/A	1.250	1.781	.359	±.016	3.000	.328	.984	.357	1.625	.718	1.187	.46
3/8	10	7,100	N/A	1.812	2.562	.468	±.031	4.078	.453	1.406	.507	2.109	1.062	1.750	1.23
1/2	13	12,000	N/A	2.156	3.250	.594	±.031	5.266	.593	1.875	.625	2.875	1.281	2.125	2.40
5/8	16	18,100	N/A	2.687	4.078	.750	±.031	6.531	.750	2.375	.750	3.562	1.593	2.500	4.17
3/4	20	28,300	N/A	3.125	5.234	.875	±.031	9.083	.875	3.503	.906	5.500	1.867	2.875	9.56

**\* ⚠ WARNING**

Do not exceed working load limits. — Use only alloy chain and attachments for lifting.

# CHAIN

## Links

Made in the U.S.A. 

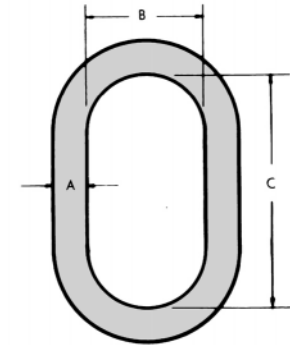
### Links

#### CM Oblong Master Link — Proof Tested

Table 2-29. CM Oblong Master Link — Proof Tested

Grade 80 Working Load Limit (lbs.)* <sup>①</sup>	Grade 100 Working Load Limit (lbs.)* <sup>①</sup>	Link Size (in.)			Type & Size of Chain Sling on Which Used (in.)				Weight Each (lbs.)
		Diameter Material A	Inside Width B	Inside Length C	Single Type S&C	Double Type D	Triple Type T	Quad Type Q	
3,600	5,400	13/32	1-1/2	3	7/32	7/32	—	—	.33
6,100	8,600	1/2	2-1/2	5	9/32	9/32	7/32	7/32	.8
12,300	17,600	3/4	2-3/4	5-1/2	3/8	3/8	9/32	9/32	2.1
20,800	30,000	1	3-1/2	7	1/2 or 5/8	1/2	3/8	3/8	4.6
31,300	45,200	1-1/4	4-3/8	8-3/4	3/4	5/8	1/2	1/2	9.2
49,000	70,600	1-1/2	5-1/4	10-1/2	7/8	3/4	5/8	5/8	15.7
73,500	105,900	1-3/4	6	12	1	7/8	3/4	3/4	24.5
88,900	N/A	2	7	14	1-1/4	1	7/8	7/8	37.3
125,200	N/A	2-1/4	8	16	—	1-1/4	1	1	54.0
187,800	N/A	2-3/4	9	16	—	—	1-1/4	1-1/4	84.8

<sup>①</sup> Working load limit of master link only.



CM Oblong Master Link

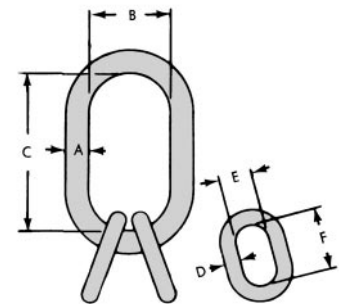
#### CM Oblong Master Link Sub-Assembly <sup>①</sup> — Proof Tested

For triple and quad branch chain slings, Grade 80 and Grade 100.

Table 2-30. CM Oblong Master Link Sub-Assembly <sup>①</sup> — Proof Tested

HA Chain (in.)	Oblong Master Link Size (in.)			Master Coupling Link Size (in.)			Weight Each (lbs.)
	A	B	C	D	E	F	
7/32	1/2	2-1/2	5	11/32	5/8	1-1/8	1.0
9/32	3/4	2-3/4	5-1/2	15/32	7/8	1-9/16	2.6
3/8	1	3-1/2	7	21/32	1-1/4	2-1/4	6.1
1/2	1-1/4	4-3/8	8-3/4	29/32	1-3/4	3-1/8	13.3
5/8	1-1/2	5-1/4	10-1/2	1-5/32	2-1/4	4	24.3
3/4	1-3/4	6	12	1-9/32	2-3/8	4-3/8	36.1
7/8	2	7	14	1-17/32	2-3/4	5-1/4	57.4
1	2-1/4	8	16	1-25/32	3	6	83.9
1-1/4	2-3/4	9	16	2-1/32	3-1/2	7	129.7

<sup>①</sup> Consisting of oblong master link and two welded master coupling links.



CM Oblong Master Link Sub-Assembly

### \* WARNING

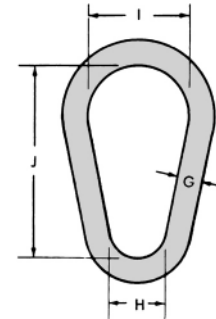
Do not exceed working load limits. — Use only alloy chain and attachments for lifting.

### CM Pear-Shaped Master Link — Proof Tested

Table 2-31. CM Pear-Shaped Master Link — Proof Tested

Link No.	Grade 80 Working Load Limit (lbs.)* <sup>①</sup>	Grade 100 Working Load Limit (lbs.)* <sup>①</sup>	Link Size (in.)				Type & Size of Chain Sling on Which Used (in.)		Weight Each (lbs.)
			Diameter Material G	Inside Widths		Inside Length J	Single Type S&C	Double Type D	
				H	I				
HA51	6,100	N/A	1/2	1-1/4	2-1/2	5-5/16	9/32	9/32	.8
HA79	12,300	N/A	3/4	2	2-3/4	5-5/8	3/8	3/8	2.1
HA103	20,800	N/A	1	2-5/8	3-1/2	7-1/4	1/2 or 5/8	1/2	4.6
HA129	31,300	N/A	1-1/4	3-1/4	4-5/8	8-3/4	3/4	5/8	9.2
HA153	49,000	N/A	1-1/2	3-7/8	5-1/4	10-1/2	7/8	3/4	15.3
HA179	59,200	N/A	1-3/4	4-1/2	6	12	1	7/8	23.9
HA201	82,600	N/A	2	3-1/2	7	14	1-1/4	1	35.9
HA229	125,200	N/A	2-1/4	6	8	16	—	1-1/4	52.8

<sup>①</sup> Working load limit of master link only.



CM Pear-Shaped Master Link

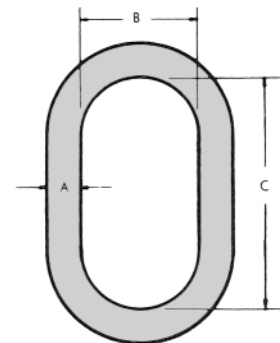
### CM Oblong Master Link — Special Sizes — Proof Tested

■ Heat treated.

Table 2-32. CM Oblong Master Link — Special Sizes — Proof Tested

Diameter (in.)	Product Code	UPC 43927-	Working Load Limit (lbs.)* <sup>①</sup>	Dimensions (in.)			Approx. Weight Each (lbs.)
				A	B	C	
1	554969	23345	18,200	1	4	8	5.3
1-1/4	554942	23332	22,800	1-1/4	6	12	12.1
1-1/2	554970	23346	42,900	1-1/2	6	12	17.6
1-1/2	554944	23334	36,700	1-1/2	7	14	20.1
1-3/4	554945	23359	63,000	1-3/4	7	14	27.9
2	554952	23340	77,800	2	8	16	41.9
2-1/2	554954	23341	147,300	2-1/2	8	16	67.0
3	554958	—	228,000	3	9	18	111.0
3-1/4	554959	—	262,200	3-1/4	10	20	144.0
3-1/2	554960	—	279,000	3-1/2	12	24	197.0

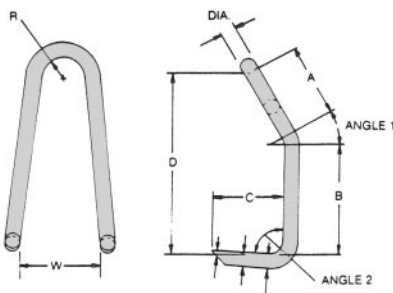
<sup>①</sup> Working load limit of master link only.



CM Oblong Master Link

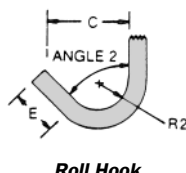
### Stirrup Hook

#### Stirrup

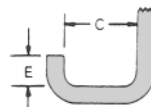


Style C

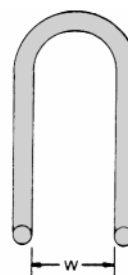
#### Stirrup Hook Options



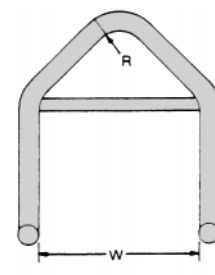
Roll Hook



Sill Hook



Style B



Style A <sup>①②</sup>

- <sup>①</sup> Optional crossbar retains stirrup on sling.
- <sup>②</sup> Optional brass or polymer non-mar pads protect sensitive surfaces.

### \*WARNING

Do not exceed working load limits. — Use only alloy chain and attachments for lifting.

# CHAIN

Amick Associates, Inc.

## Accessories

version #2-04

Made in the U.S.A. 

### Accessories

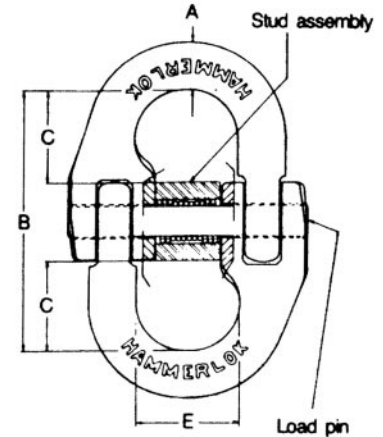
#### CM Hammerlok Coupling Link — Proof Tested

Dependable and easy to use for fast assembly on the job, for attaching chain to master links and eye type hooks, and for installing new body chain in old slings. C.V.S.A approved.

Table 2-33. CM Hammerlok Coupling Link — Proof Tested

Chain Size (in.)	Grade 80 Working Load Limit (lbs.)*	Grade 100 Working Load Limit (lbs.)*	Dimensions (inches)						Weight Each (lbs.)
			A	B	C	E ①	Max. Width	Diameter Hole to Accept Male Leg	
7/32	2,100	N/A	1/4	1-13/32	31/64	13/32	1-5/16	1/2	.12
9/32	3,500	N/A	5/16	1-13/16	5/8	1/2	1-11/16	35/64	.23
3/8	7,100	N/A	1/2	2-13/32	53/64	3/4	2-7/32	47/64	.65
1/2	12,000	N/A	11/16	3-3/8	1-7/32	1	3-1/8	59/64	1.5
5/8	18,100	N/A	13/16	4-1/16	1-1/2	1-1/4	3-11/16	1-1/16	2.6
3/4	28,300	N/A	15/16	4-25/32	1-51/64	1-1/2	4-5/16	1-1/4	3.8
7/8	34,200	N/A	1-3/64	5-1/8	1-29/32	1-3/4	5-5/16	1-11/32	6.3
1	47,700	N/A	1-1/4	5-3/4	2-3/16	2	6-3/16	1-9/16	9.3
1-1/4	72,300	N/A	1-17/32	6-13/16	2-5/8	2-1/4	7-3/4	2	17.3

① Diameter of stock of largest master link intended to be used with Hammerlok.

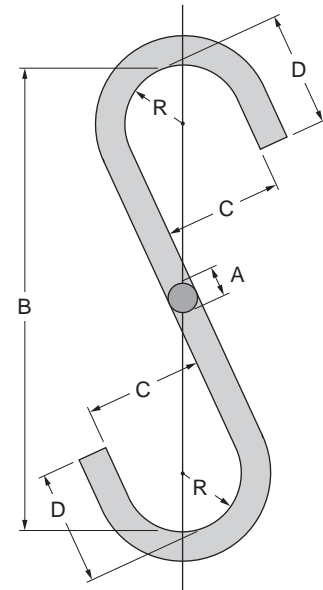


CM Hammerlok Coupling Link

#### CM S Hook — Proof Tested

Table 2-34. CM S Hook — Proof Tested

Size A (in.)	Grade 80 Working Load Limit (lbs.)*	Grade 100 Working Load Limit (lbs.)*	Dimensions (inches)				Weight Each (lbs.)
			B	C	D	R	
9/32	210	N/A	4-1/2	1-1/8	1-1/8	9/16	.15
3/8	410	N/A	6	1-1/2	1-1/2	3/4	.35
1/2	870	N/A	7-1/2	2	2	1	.82
5/8	1,120	N/A	9	2-1/2	2-1/2	1-1/4	1.6
3/4	1,730	N/A	10-1/2	3	3	1-1/2	2.6
7/8	2,370	N/A	12	3-1/2	3-1/2	1-3/4	4.2
1	2,920	N/A	13	4	4	2	6.0
1-5/32	3,150	N/A	15	4-1/2	4-1/2	2-1/4	9.3
1-1/4	4,450	N/A	16	5	5	2-1/2	11.7
1-3/8	6,100	N/A	17	5-1/2	5-1/2	2-3/4	15.4
1-1/2	6,250	N/A	18	6	6	3	19.5

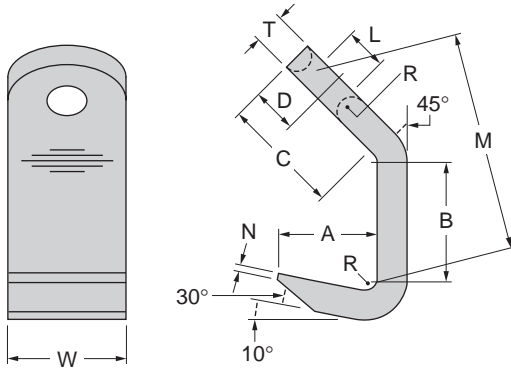


CM S Hook

### \* WARNING

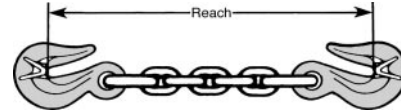
Do not exceed working load limits. — Use only alloy chain and attachments for lifting.

### CM Plate Hook — Proof Tested



### CM Chain Shortener

Standard arrangement consists of five links of body chain, two coupling links and two grab hooks as illustrated.



### CM Hook Latch Kits

Kit includes all hardware for easy installation on CM eye and Clevlok sling hooks.



Current Style Latch



Old Style Latch

Table 2-35. CM Plate Hook — Proof Tested

Chain Size (in.)	Grade 80 Working Load Limit (lbs.)*	Grade 100 Working Load Limit (lbs.)*	Dimensions (inches)										Weight Each (lbs.)
			A	B	C	D	L	M	N	T	R	W	
9/32	3,600	N/A	2	1-3/4	2-1/2	15/16	1	3-11/16	1/8	5/8	5/16	2-1/2	2.8
3/8	7,050	N/A	2-5/8	3	4-5/16	1-3/16	1-1/8	6-3/8	3/16	3/4	3/8	2-3/4	5.7
1/2	11,400	N/A	3-1/2	4	4-3/8	1-1/2	1-1/2	7-3/8	1/4	1	1/2	3-1/2	13.0
5/8	17,800	N/A	4-3/8	5	5-7/16	1-7/8	1-7/8	9-1/4	5/16	1-1/4	5/8	5	26.5
3/4	25,600	N/A	5-3/16	6	6-1/2	2-3/8	2-1/4	10-7/8	3/8	1-1/2	3/4	5-3/4	42.0
7/8	34,900	N/A	6	7	7-5/8	2-1/2	2-5/8	13-1/16	7/16	1-3/4	1	6	65.0

Note: For mechanical assembled slings, next larger size Hammerlok coupling link is required in addition to regular size Hammerlok coupling link.

Table 2-36. CM Chain Shortener

Chain Size (in.)	Grade 80 Working Load Limit (lbs.)*	Grade 100 Working Load Limit (lbs.)*	Reach (in.)
7/32	N/A	2,700	10-1/4
9/32	3,500	4,300	11-1/4
3/8	7,100	8,800	15-3/8
1/2	12,000	15,000	19-3/8
5/8	18,100	22,600	23-3/8
3/4	28,300	35,300	28
7/8	34,200	N/A	33-1/4
1	47,700	N/A	37-1/2
1-1/4	72,300	N/A	47-3/4

Table 2-37. CM Hook Latch Kits

Chain Size (in.)	Grade 80		Grade 100
	Current Style	Old Style	Current Style
	Product Code	Product Code	Product Code
7/32	—	595461	N/A
9/32	595523	595461	595523
3/8	595525	595463	595525
1/2	595528	595474	595528
5/8	595529	595465	595529
3/4	595530	595466	595530
7/8	595532	595467	N/A
1	595533	595468	N/A
1-1/4	595535	595469	N/A

**\*WARNING** Do not exceed working load limits. — Use only alloy chain and attachments for lifting.

# CHAIN

Amick Associates, Inc.

## Welded Chain & Assemblies

version #2-04

Made in the U.S.A. 

### Welded Chain & Assemblies

#### CM Binder Chain Assemblies

Table 2-38. CM Binder Chain Assemblies

Size	Approx. Weight Each (lbs.)	High Test	Grade 70	Herc Alloy 800
		Working Load Limits (lbs.)	Working Load Limits (lbs.)	Working Load Limits (lbs.)
1/4" x 20'	16	2,600	3,150	–
5/16" x 20'	25	3,900	4,700	–
3/8" x 20'	35	5,400	6,600	7,300
7/16" x 20'	46	7,200	8,750	–
1/2" x 20'	58	9,200	11,300	13,000
5/8" x 20'	92	11,500	17,000	20,300



Binder Chain

#### CM Coil Chain

Regular finish is Bright (polished), also zinc-plated and hot galvanized. Supplied Twist Link unless otherwise specified.

Table 2-39. CM Coil Chain

Trade No.	Fractional Inches	Twist Link			Straight Link		
		Links per ft.	Weight per 100 ft. (lbs.)	Working Load Limits (lbs.)	Links per ft.	Weight per 100 ft. (lbs.)	Working Load Limits (lbs.)
4	1/8	11	10	195	10-1/2	10	205
3	9/64	10-1/2	13	240	10-1/4	13	255
2	5/32	10-1/2	16	295	10-1/4	15	310
1/0	11/64	9-3/4	24	415	9-3/4	23	440
2/0	3/16	9-3/4	29	495	9-1/4	27	520
4/0	7/32	8-3/4	36	635	8-1/2	35	670
5/0	1/4	8-1/8	48	835	7-7/8	46	880



Twist Link Coil Chain



Straight Link Coil Chain

#### CM Machine Chain

Regular finish is Bright (polished), also zinc-plated and hot galvanized. Supplied Twist Link unless otherwise specified.

Table 2-40. CM Machine Chain

Trade No.	Fractional Inches	Twist Link			Straight Link		
		Links per ft.	Weight per 100 ft. (lbs.)	Working Load Limits (lbs.)	Links per ft.	Weight per 100 ft. (lbs.)	Working Load Limits (lbs.)
4	1/8	23-1/2	13	205	22	12	215
3	9/64	21-1/2	16	255	20	15	270
2	5/32	21	20	310	20	19	325
1/0	11/64	17-1/2	29	440	16-1/2	27	465
2/0	3/16	16-1/2	34	520	15-1/4	32	545
4/0	7/32	14	43	670	13-1/4	41	700
5/0	1/4	12	57	880	11-1/4	54	925



Twist Link Machine Chain



Straight Link Machine Chain

### \* WARNING

Do not use chains on this page for overhead lifting.

### CM Adjust-A-Link sling

- Adjustable all-purpose sling.
- Lifts even/uneven loads easily.
- Lightweight and portable.
- Available in 6' and 10' reach.
- Available in 7/32", 9/32" x 3/8" grade 80 alloy chain.
- All components proof tested.
- Alloy steel master/control link.
- Each assembly serialized and tagged.

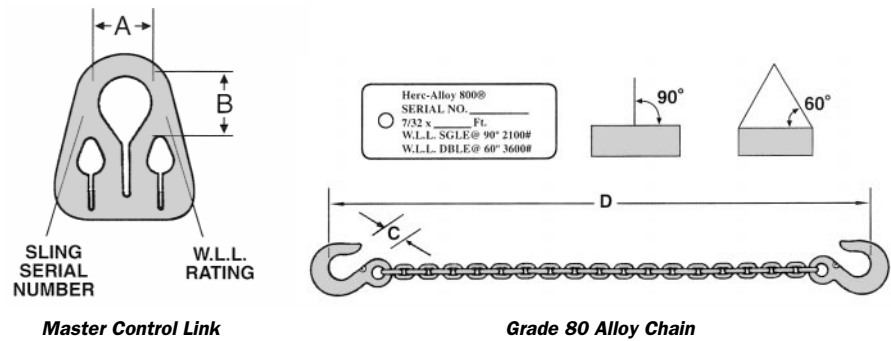
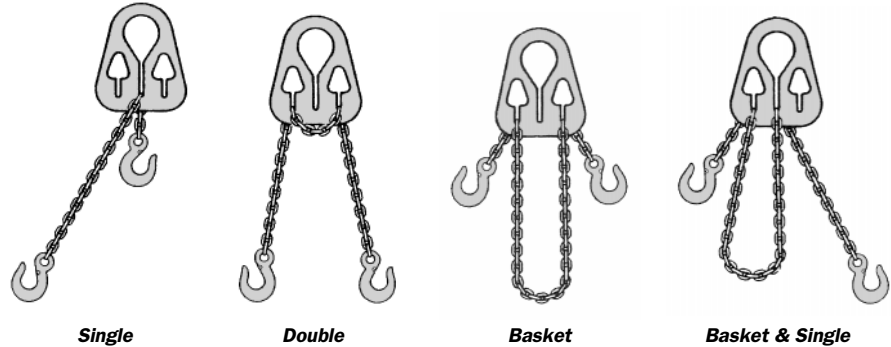


Table 2-41. CM Adjust-A-Link Sling

Chain Size (in.)	Product Code	UPC 43927-	Chain Reach D (ft.)	Working Load Limit (lbs.)		Link Dimensions (in.)			Weight (lbs.)
				Single at 90°	Double at 60°	A	B	C	
7/32	607971	20921	6	2,100	3,600	2	2	15/16	4-1/2
7/32	607972	20922	10	2,100	3,600	2	2	15/16	6-1/2
9/32	607974	20924	6	3,500	6,100	3	3-1/2	1-1/16	8
9/32	607975	20925	10	3,500	6,100	3	3-1/2	1-1/16	11
3/8	607976	20926	10	7,100	12,300	3-1/4	3-1/4	1-9/16	19

**\* ⚠ WARNING** Do not use chains on this page for overhead lifting.

# CHAIN

Amick Associates, Inc.

## Carbon Chain

version #2-04

Made in the U.S.A. 

### Carbon Chain

#### CM Grade 30 Proof Coil Chain

Low carbon steel utility chain with a wide range of general purpose uses. Self-colored (natural) finish. Links embossed every 10 inches with the make and grade appearing alternately. Also available in Hot Galvanized or Bright Zinc finish.

Table 2-42. CM Grade 30 Proof Coil Chain

Trade Size (in.)	Material Size (in.)	Weight per 100 ft. (lbs.)	Working Load Limit (lbs.)
3/16	7/32	38	800
1/4	9/32	66	1,300
5/16	11/32	98	1,900
3/8	13/32	144	2,650
7/16	15/32	210	3,700
1/2	17/32	278	4,500
5/8	21/32	422	6,900
3/4	25/32	628	10,600
1	1-1/32	1,069	17,900



Proof Coil Chain

#### CM Grade 43 High Test Chain

Made from a selected analysis carbon steel to provide higher tensile strength and working load limits, as well as better resistance to wear. Bright (polished) finish. Embossed every 10 inches with the make and grade appearing alternately. Also available in Hot Galvanized and Bright Zinc finish.

Table 2-43. CM Grade 43 High Test Chain

Trade Size (in.)	Material Size (in.)	Weight per 100 ft. (lbs.)	Working Load Limit (lbs.)
1/4	9/32	71	2,600
5/16	11/32	98	3,900
3/8	13/32	144	5,400
7/16	15/32	210	7,200
1/2	17/32	278	9,200
5/8	21/32	422	13,000
3/4	25/32	606	20,200
7/8	29/32	776	24,500
1	1-1/32	1,050	34,100



High Test Chain

#### CM Grade 70 Transportation — Binder Chain

Significantly higher tensile strength for all load binding and tie down applications, which permits you to hold a given load with the next smaller size chain than Grade 43. This increased strength-to-weight ratio means lower costs and a lighter chain, for easier storage and handling. GOLD finish. Embossed every 10 inches, with the make and grade appearing alternately.

Table 2-44. CM Grade 70 Transportation — Binder Chain

Trade Size (in.)	Material Size (in.)	Weight per 100 ft. (lbs.)	Working Load Limit (lbs.)
1/4	9/32	74	3,150
5/16	11/32	100	4,700
3/8	13/32	156	6,600
7/16	15/32	204	8,750
1/2	17/32	259	11,300



Transportation — Binder Chain

### \* WARNING

Do not use chains on this page for overhead lifting.

## Chain Inspections & Repairs

As part of our comprehensive service and safety programs for our valued customers, Amick Associates offers regularly scheduled chain inspections. Customers can schedule chain inspections annually, semi-annually, or quarterly with minimal interruption of plant work schedules.

### About the Inspection:

- Chains are visually inspected for wear, cracks, gouges, and deformations of the chain slings and lifting devices.
- A customer representative may join the inspection if he/she wishes to do so, however, it is not required.
- Any items failing inspection will be danger tagged and removed from service immediately.
- Before leaving the customer's premises, the Amick chain inspector will review the inspection with a customer representative to discuss corrective action or procedures.
- A complete, written inspection report will be sent to the customer one week after the inspection detailing the condition of every chain inspected.

### About the Repairs:

- Chains danger tagged will be brought back to Amick Associates, home of the largest chain repair station in western Pennsylvania. We are capable of repairing and/or replacing all brands of chain and fittings with a minimal turnaround time.
- Customers will receive a 'new vs. repair' quote before any corrective action is taken.

*This Page Intentionally Left Blank*

# WIRE ROPE

3

## **Wire Rope Basics**

- A Wire Rope is a "Machine" with Many Moving Parts
- Application Recommendations
- Constructions of Wire Rope

## **Wire Rope Products**

- Standard 6 x 19 and 6 x 36 Classification Ropes
- Rotation-Resistant Ropes
- Premium Value Ropes
- "Compacted" Non-Rotating Ropes

## **Stainless Steel Cables**

- Various Alloys Used
- Corrosion Resistance
- Why Type 302 is a Better Alloy for Making Cable

## **Proper Wire Rope Use**

- Unreeling and Uncoiling
- Winding Wire Rope
- Installing Rope on Drums
- Inspection and Removal Criteria
- Attaching Clips

## **Press-Grip Slings**

## **Grommet Slings**

## **Uni-Ply (Cable-Laid)**

## **Hand-Spliced Slings**

## **Hand-Braided Slings**

- 8 Part
- 6 Part
- 3 Part
- 7 Part

## **Wire Rope Inspections and Repairs**

# WIRE ROPE

## Wire Rope Basics

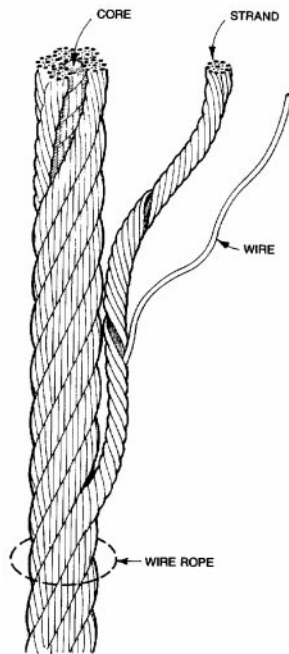
### Wire Rope Basics

#### A Wire Rope is a “Machine” With Many Moving Parts

From childhood, many of us have been conditioned to think of a machine as some device with gears, shafts, belts, cams, and assorted whirring parts. Yet, by the rules of physics, an ordinary pry bar is a simple machine, even though it has only one part.

A wire rope is in reality a very complicated machine. A typical 6 x 25 rope has 150 wires in its strands, all of which move independently and together in a very complicated pattern around the core as the rope bends. Clearances between wires are balanced when a rope is designed so that proper bearing clearances will exist to permit internal movement and adjustment of wires and strands when the rope has to bend. These clearances will vary as bending occurs, but are of the same range as the clearances found in automobile engine bearings.

Understanding and accepting the “machine idea” gives a rope user a greater respect for rope, and enables him to obtain better performance and longer useful life from rope applications. Anyone who uses a rope can use it more efficiently and effectively when he fully understands the machine concept.



#### How a Wire Rope “Machine” Works

The extent to which wires move in a rope when it bends is illustrated by the following example – what actually happens when you wrap a 1-inch rope over a 30-inch sheave. Between the point where the rope first touches the sheave on one side, and where it leaves the sheave on the other side, the length of rope in contact with the sheave would be 3-1/8 inches shorter than the length of the side away from the sheave – if the rope did not move and adjust internally by wires sliding back and forth.

The mathematics is simple: just subtract half the circumference of a 30-inch circle from half the circumference of a 32-inch circle.

$$Circumference = \pi \times Diameter$$

$$C = 3.1416 \times 32 = 100.5312$$

$$C = 3.1416 \times 30 = \frac{94.2490}{6.2931} \div 2 = 3.14$$

Thus, circumference of a 32-inch circle is slightly more than 6-1/4 inches longer than that of a 30-inch circle. Since a rope only touches half a sheave at any time, the length differential which a rope must accommodate is 3-1/8 inches. By this same reasoning, a 1-inch rope wrapped on a 30-inch hoist drum must compensate internally for a 6-1/4 inch length differential in each wrap.

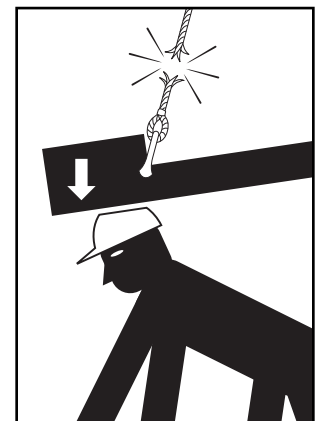
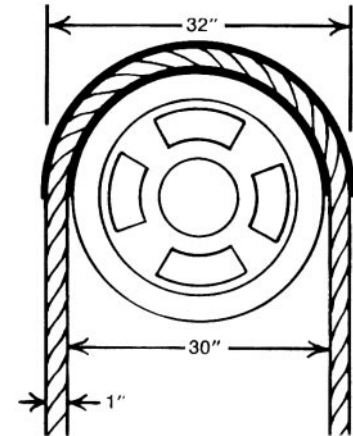
This change of dimension is achieved by the sliding and adjusting of the strands in relation to one another, and a similar sliding and adjusting of the individual wires within each strand.

By painting stripes around a wire rope as illustrated here and actually bending the rope, we can see the movement of strands as the rope bends. Anytime a rope flexes, this movement takes place. The sharper the bend, the more the movement.

#### \*Warning – Protect yourself and others:

- ALWAYS INSPECT wire rope for WEAR, DAMAGE or ABUSE BEFORE USE.
- NEVER USE wire rope that is WORN-OUT, DAMAGED or ABUSED.
- NEVER OVERLOAD a wire rope.
- INFORM YOURSELF: Read and understand manufacturer’s literature or “Wire Rope and Wire Rope Sling Safety Bulletin.”
- REFER TO APPLICABLE CODES, STANDARDS and REGULATIONS for INSPECTION REQUIREMENTS and REMOVAL CRITERIA.

**Note:** For additional information or the Bulletin, ask your employer or wire rope supplier.



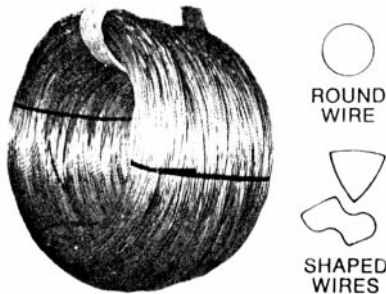
#### \*WARNING

Wire rope WILL FAIL if worn-out, overloaded, misused, damaged, improperly maintained or abused. Wire rope failure may cause serious injury or death! See above.

### The “Parts List” of a Wire Rope Machine

#### The Wire

The basic element of wire rope is, of course, the wire – usually round, but sometimes shaped. It is all “cold drawn” to the desired diameter and physical properties after special heat-treating. Most wire is made to one of two grades – Improved Plow Steel (IPS), or Extra Improved Plow Steel (XXIP) which has about 15% greater tensile strength. Both grades are carbon steel that is tough and resists wear. When the wire has a natural finish, it is called “Bright.” Otherwise it is plated, galvanized, or may have some other surface treatment for special applications.



#### The Core

Rope cores are usually one of three types:

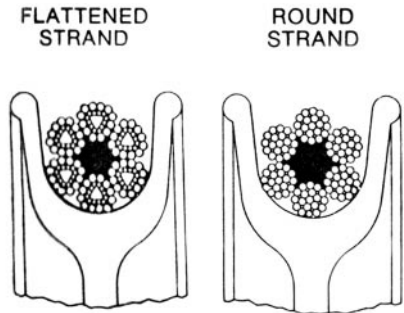
1. **Fiber rope core** – either natural sisal fiber, or man-made fiber such as polypropylene.
2. **Wire rope core** – literally an independent wire rope, which is called IWRC.
3. **Strand core** – which is a typical wire rope strand.

The primary purpose of a rope core is to provide a foundation, or support, for the strands. Approximately 7-1/2% of the rope's strength of a 6-strand IWRC rope is attributed to the core.



#### The Strands

The greatest differences between wire ropes occur in the number of strands and in the number and pattern of wires per strand. There are two general types – round strands, and strands that have been shaped or formed. Strand design is a precise engineering science.



#### Preforming

In most ropes made today, the strands are “preformed” just before they are laid together to make the rope. Preforming is a mechanical operation by which the individual strands are formed into a continuous helical shape which causes them to be at rest in the rope. Preforming serves two functions: It maintains the rope's shape when it is cut, and it forms the strands in such a way that they will slide and adjust together more smoothly within the rope when the rope works.

# WIRE ROPE

Amick Associates, Inc.

## Wire Rope Basics

version #1-18

### Cranes – Mobile (Truck Mounted or Locomotive)



### Application Recommendations

**Hoist Line:** 6 x 25 FW EIP or IPS regular lay IWRC

— *As an alternate more flexible rope and particularly in larger sizes. 6 x 41 WS EIP regular lay IWRC may be used.*

For rotation-resistant requirements: 19 x 19 EEIP, or 19 x 7 or 8 x 19 EIP

**Boom Line:** Up through 5/8": 6 x 25 FW EIP or IPS regular lay IWRC or 6 x 26 WS alternate lay EIP IWRC (through 1")

*Larger sizes of alternate lay on request.*

3/4" through 1": 6 x 26 WS EIP or IPS lang lay IWRC

1-1/8" and larger: 6 x 41 WS EIP or lang lay IWRC

### Cranes (Extendable Boom)

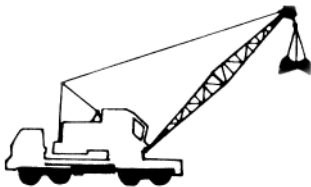


**Boom extension** where applicable: 6 x 25 or 6 x 26 WS EIP or IPS regular lay IWRC

**Main Hoist:** For rotation-resistant requirements: 10 x 19 EIP or 19 x 7 or 8 x 19 EIP

— *Always select rope whose strength is consistent with the rated capacity of the crane. These ropes have different strengths. Their nominal strength is predicated on fixed ends. Swivels drastically reduce strength.*

### Clamshell Crane



**Holding Line:** 6 x 25 FW EIP or IPS regular lay IWRC

**Closing Line:** 6 x 25 FW EIP or IPS regular lay IWRC

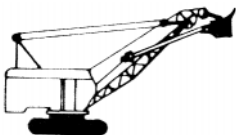
**Boom Line:** Up through 5/8": 6 x 25 FW EIP or IPS regular lay IWRC or 6 x 26 WS alternate lay EIP IWRC (through 1")

*Larger sizes of alternate lay on request.*

3/4" through 1": 6 x 26 WS EIP or IPS lang lay IWRC

1-1/8" and larger: 6 x 41 WS EIP lang lay IWRC

### Shovels



**Hoist:** Up through 5/8": 6 x 25 FW EIP or IPS regular lay IWRC

3/4" through 1-1/8": 6 x 25 FW EIP lang lay IWRC

1-1/4" – 2": 6 x 41 WS EIP lang lay IWRC

**Boom:** Up through 5/8": 6 x 25 FW EIP or IPS regular lay IWRC

3/4" through 1": 6 x 26 WS EIP or IPS lang lay IWRC

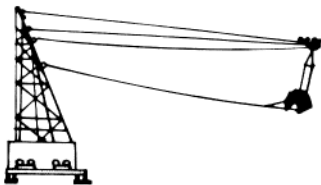
1-1/8" and up: 6 x 41 WS EIP lang lay IWRC

**Crowd:** Up through 7/8": 6 x 26 WS EIP or IPS lang lay IWRC

1" and above: 6 x 41 WS EIP lang lay IWRC

**Trip Line:** 6 x 19 class IPS regular lay F/C

### Drag Scrapers (Sauerman Type)

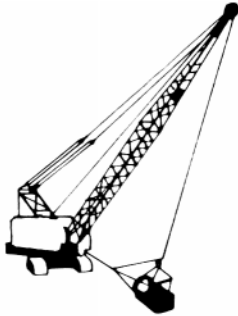


**Drag or Inhaul:** All sizes: 6 x 26 WS EIP or IPS lang lay IWRC

**Tail or Haulback Line:** All sizes: 6 x 26 WS EIP or IPS lang lay IWRC

The applications shown represent common, appropriate uses of wire rope for construction, excavation, and general purposes. This is provided to aid wire rope buyers and users in their selection.

### Drag Line Excavators



### Application Recommendations

**Hoist:** Up through 5/8": 6 x 25 FW EIP or IPS regular lay IWRC

3/4" – 1": 6 x 25 FW or 6 x 26 WS EIP or IPS lang lay IWRC

1-1/8" and larger: 6 x 41 WS EIP or IPS lang lay IWRC

**Drag Line:** Up through 1-5/8": 6 x 26 WS EIP lang lay IWRC

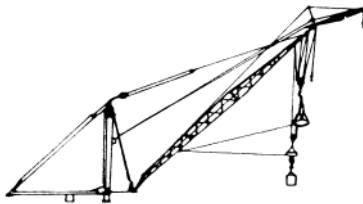
1-3/4" and larger: 6 x 25 FW EIP lang lay IWRC

**Boom Hoist:** Up through 5/8": 6 x 25 FW EIP or IPS regular lay IWRC

3/4" through 1": 6 x 26 WS EIP or IPS lang lay IWRC

1-1/8" and larger: 6 x 41 WS EIP lang lay IWRC

### Derricks



**Hoist Line:** (Multiple Reeved): 6 x 25 FW EIP or IPS regular lay IWRC

— For single line, a rotation resistant rope such as 19 x 7 or 8 x 19 rotation resistant may be required.

**Boom Line:** Up through 5/8": 6 x 25 FW EIP or IPS regular lay IWRC

3/4" through 1": 6 x 26 WS EIP or IPS lang lay IWRC

1-1/8" and larger: 6 x 41 WS EIP or IPS lang lay IWRC

**Swing Line:** 6 x 25 FW IPS regular lay IWRC

**Guy Line:** 6 x 7 or 6 x 19 EIP or IPS regular lay F/C

### Pile Drivers



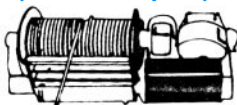
6 x 25 FW EIP or IPS regular lay IWRC

6 x 31 WS EIP or IPS regular lay IWRC

6 x 36 WS EIP or IPS regular lay IWRC

1" and larger: 6 x 41 WS EIP regular lay IWRC

### Winches (General Purpose)



6 x 25 FW EIP or IPS regular lay IWRC

6 x 31 WS EIP or IPS regular lay IWRC

### Cranes (Overhead Traveling)



1/4" through 1/2": 6 x 19 class EIP or IPS regular lay IWRC

Above 1/2": 6 x 41 WS EIP or IPS regular lay IWRC

— Fiber core ropes may be used if loads permit. IWRC is mandatory for temperatures above 200°F.

### Cranes (Small Shop Hoists)

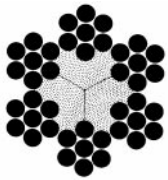


1/4" – 3/8": 6 x 37 class IPS regular lay F/C or IWRC

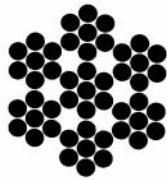
# WIRE ROPE

## Wire Rope Basics

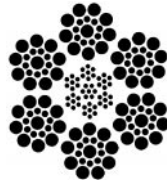
### Constructions of Wire Rope



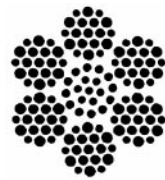
6 x 7



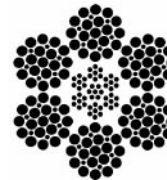
7 x 7



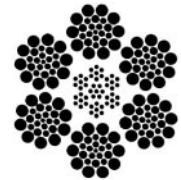
6 x 19 Seale  
(7 x 7 IWRC)



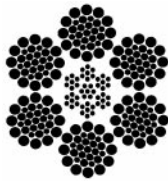
6 x 19 Warrington  
(1 x 19 Strand Core)



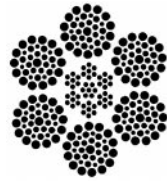
6 x 25 Filler Wire  
(7 x 7 IWRC)



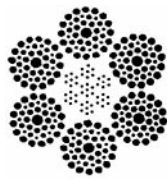
6 x 26 Warrington  
Seale (7 x 7 IWRC)



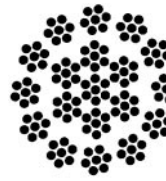
6 x 31 Warrington  
Seale (7 x 7 IWRC)



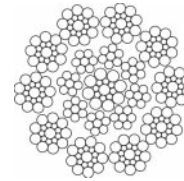
6 x 36 Warrington  
Seale (7 x 7 IWRC)



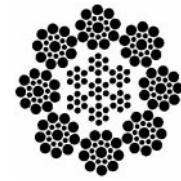
6 x 41 Warrington  
Seale (7 x 7 IWRC)



19 x 7 Rotation  
Resistant



10 x 19

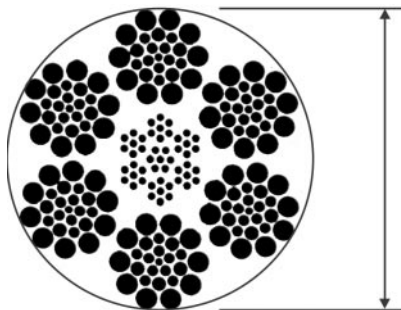


8 x 19 Seale  
(IWRC)

### How to Measure Wire Rope Diameter

The correct diameter of a wire rope is the diameter of a circumscribed circle that will enclose all the strands. It's the largest cross-sectional measurement as shown here.

You should make the measurement carefully with calipers. These illustrations show the correct and incorrect methods of measuring a wire rope's diameter.



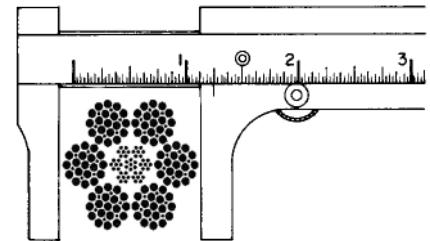
True Diameter

### Allowable Tolerance in Wire Rope Diameter

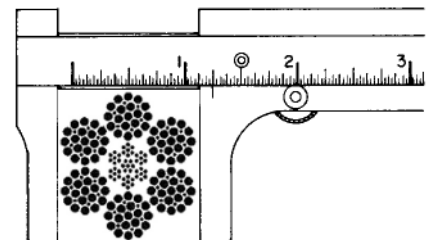
Wire rope is normally made slightly larger than its catalog (or nominal) size. The following chart lists the size tolerances of wire rope.

**Table 3-1. Allowable Tolerance in Wire Rope Diameter**

Nominal Rope Diameter (in.)	Tolerance	
	Under	Over
0 – 1/8	-0	+8%
Over 1/8 – 3/16	-0	+7%
Over 3/16 – 5/16	-0	+6%
Over 5/16	-0	+5%



Correct



Incorrect

## Wire Rope Products

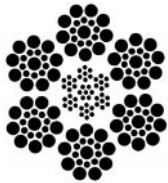
### Standard 6 x 19 and 6 x 36 Classification Ropes

The 6 x 19 classification of wire ropes includes standard 6 strand, round strand ropes with 16 through 26 wires per strand. The 6 x 36 classification of wire ropes includes standard 6 strand, round strand ropes with 27 through 49 wires per strand. Although their operating characteristics vary, all have the same weight per foot and the same nominal strength, size for size.

While the 6 x 19 ropes give primary emphasis to abrasion resistance in varying degrees, the 6 x 36 ropes are important for their fatigue resistance. This fatigue resistance is made possible by the greater number of small wires per strand.

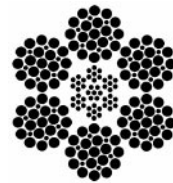
Although there are exceptions for special applications, the constructions in 6 x 36 classification are primarily designed to be the most efficient for each rope diameter. As the rope size increases, for instance, a large number of wires can be used to achieve required fatigue resistance, and still those wires will be large enough to offer adequate resistance to abrasion.

#### 6 x 19 Classification Ropes



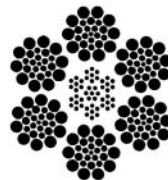
**6 x 19 S (Seale)**

**6 x 19 S (Seale)** In this construction, each strand has nine outer wires over nine smaller inner wires over one large center wire. A comparison of cross-sections shows that these outside wires are larger than those of the 6 x 25 FW or 6 x 26 WS. Therefore, its resistance to abrasion is increased, but its fatigue resistance is decreased. This is a good rope to withstand abrasion or crushing on the drum.



**6 x 25 FW (Filler Wire)**

**6 x 25 FW (Filler Wire)** To most wire rope users, 6 x 19 means 6 x 25 filler wire. It was the most common rope in the 6 x 19 classification. This rope has a good balance between both abrasion resistance and fatigue resistance in relation to other ropes.

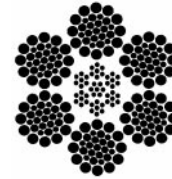


**6 x 26 WS (Warrington Seale)**

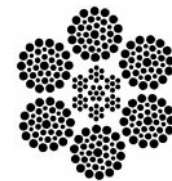
**6 x 26 WS (Warrington Seale)** This construction has better resistance to abrasion than a 6 x 25 FW. It also features a compact construction with solid support for the wires; hence, it has a high resistance to crushing. Its number and relative size of the inner wires add to the stability of the strand and gives it a fatigue resistance comparable to a 6 x 25 FW.

A standard 6 x 26 WS construction provides the best rope for a wide range of applications. In general, we recommend the use of a 6 x 26 WS in any application where a 6 x 25 FW is used.

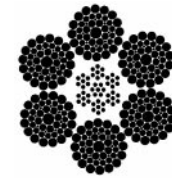
#### 6 x 36 Classification Ropes



**6 x 31 WS (Warrington Seale)**



**6 x 36 WS (Warrington Seale)**



**6 x 49 SWS (Seale Warrington Seale)**

In most rope sizes, only one 6 x 36 classification rope is made. These constructions were selected to provide fatigue resistance without having wires that are too small.

The greater number of wires in the 6 x 36 classification makes these ropes more susceptible to crushing. This can be minimized, however, by specifying an Independent Wire Rope Core (IWRC) and by using well-designed sheaves, grooved drums and proper operating techniques.

# WIRE ROPE

Amick Associates, Inc.

## Wire Rope Products

version #1-18

Table 3-2. Nominal Strengths and Weights for Standard 6 x 19 and 6 x 36 Classification Ropes

Diameter (in.)	Fiber Core			IWRC			
	Approx. wt./ft. (lbs.)	Nominal Strength (Tons of 2,000 lbs.)		Approx. wt./ft. (lbs.)	Nominal Strength (Tons of 2,000 lbs.)		
		IPS	XIP®		IPS	XIP®	XXIP®
3/16	0.059	1.55	1.71				
1/4	0.105	2.74	3.02	0.116	2.94	3.40	
5/16	0.164	4.26	4.69	0.18	4.58	5.27	
3/8	0.236	6.10	6.72	0.26	6.56	7.55	8.30
7/16	0.32	8.27	9.10	0.35	8.89	10.2	11.2
1/2	0.42	10.7	11.8	0.46	11.5	13.3	14.6
9/16	0.53	13.5	14.9	0.59	14.5	16.8	18.5
5/8	0.66	16.7	18.3	0.72	17.9	20.6	22.7
3/4	0.95	23.8	26.2	1.04	25.6	29.4	32.4
7/8	1.29	32.2	35.4	1.42	34.6	39.8	43.8
1	1.68	41.8	46.0	1.85	44.9	51.7	56.9
1-1/8	2.13	52.6	57.8	2.34	56.5	65.0	71.5
1-1/4	2.63	64.6	71.1	2.89	69.4	79.9	87.9
1-3/8	3.18	77.7	85.5	3.50	83.5	96.0	106.0
1-1/2	3.78	92.0	101.0	4.16	98.9	114.0	125.0
1-5/8	4.44	107.0	118.0	4.88	115.0	132.0	146.0
1-3/4	5.15	124.0	137.0	5.67	133.0	153.0	169.0
1-7/8	5.91	141.0	156.0	6.50	152.0	174.0	192.0
2	6.72	160.0	176.0	7.39	172.0	198.0	217.0
2-1/8	7.59	179.0	197.0	8.35	192.0	221.0	244.0
2-1/4	8.51	200.0	220.0	9.36	215.0	247.0	272.0
2-3/8				10.4	239.0	274.0	
2-1/2				11.6	262.0	302.0	
2-5/8				12.8	288.0	331.0	
2-3/4				14.0	314.0	361.0	
2-7/8				15.3	341.0	392.0	
3				16.6	370.0	425.0	
3-1/8				18.0	399.0	458.0	
3-1/4				19.5	429.0	492.0	
3-3/8				21.0	459.0	529.0	
3-1/2				22.7	491.0	564.0	
3-5/8				24.3	523.0	602.0	
3-3/4				26.0	557.0	641.0	
3-7/8				27.7	591.0	680.0	
4				29.6	627.0	720.0	
4-1/8				31.7	658.0	757.0	
4-1/4				33.3	694.0	799.0	
4-3/8				35.4	734.0	844.0	

Note: Available galvanized at 10% lower strengths, or in equivalent strengths on special request.

## Rotation-Resistant Ropes

Rotation-resistant ropes can frequently provide the best and most economical service in specific applications when you choose, handle and use them properly.

Contra-helically laid, rotation-resistant ropes are different from standard ropes because they're designed to reduce rope torque. Modes of failure and wear for rotation-resistant ropes can differ from those for standard rope constructions. The very nature of these ropes requires special handling, selection and usage not encountered with standard constructions. They are susceptible to kinking, crushing and unbalancing in the form of "core pops" and "birdcages." Use extreme care to avoid operational practices that can possibly lead to these conditions.

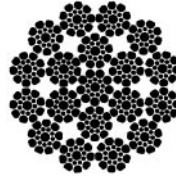
Rotation-resistant ropes should not be used with swivels that allow rope rotation — or in single part lifts where the load can rotate. Rotation will cause a reduction in strength, unequal loading in the rope and possible rope unbalance. If any significant change in diameter is found in a short length of a rotation-resistant rope, the rope needs to be replaced.

These ropes should be replaced when you see two randomly distributed crown wire breaks in six rope diameters — or four randomly distributed crown wire breaks in 30 rope diameters.

Because rotation-resistant ropes are special, there are separate design, maintenance, inspection and removal criteria established for them by applicable industry regulations and standards.

We recommend that rotation-resistant ropes be used with a minimum design factor of 5.0.

### Flex-X®19



*Flex-X 19*

Flex-X delivers extra value when you need high strength in a rotation-resistant wire rope. Its rotation-resistant construction provides a smooth, extremely compact wire rope with more steel in the cross-section than conventional ropes.

Flex-X 19 is made from 19-wire Seale strands. Six strands are laid around a core strand in one direction, then 12 strands are laid around this first operation in the opposite direction. Because of its tightly compacted, smooth design, Flex-X 19 offers advantages:

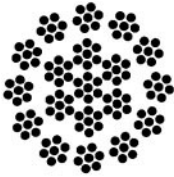
- More crush resistance than a standard 19 x 7 rope while providing the same rotation resistance.
- Higher strength-to-diameter due to compacted wires in the strands. With increased metallic area, it provides rope strengths equal to 6 strand XXIP IWRC ropes of the same diameter.
- Resistance to bending fatigue due to the uniformity of the wires within each strand. The strand's outer surface is smooth, reducing contact pressures between the rope's strands and radial pressures as it operates over sheaves and drums.
- Exceptional stability due to the higher density strands compiled with the smooth outer surface.
- Improved handling, operating and spooling characteristics.
- Reduced wear to sheaves and drums.

Flex-X has also demonstrated greater fatigue resistance to substantially cut rope expense and extend rope service life. It's ideal for single-part or multi-part hoist lines wherever you encounter spooling problems, drum crushing, block twisting or have fast line speeds.

# WIRE ROPE

## Wire Rope Products

### 19 x 7 Rope



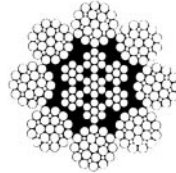
19 x 7

In an application where a single part hoist rope is used to lift a free load — or where rotation-resistant properties are essential for rope performance — the 19 x 7 can be used.

Its rotation-resistant characteristic is achieved by laying six strands around a core strand in one direction, then laying 12 strands around the first operation in the opposite direction. Thus, when the rope is in tension, opposing rotational forces are created between the inner and outer layers.

In addition, frequent and regular inspection for broken wires is critical when using this rope. Due to its design, the 19 x 7 construction has a relatively low reserve strength. This can result in short service life between the point in time when the broken wire removal criteria are met and when actual rope failure occurs.

### 8 x 25 Resistwist® Rope



8 x 25 FW

In a multi-part wire rope system where the blocks have a tendency to twist — or for a single-part hoist line that doesn't require the degree of rotation-resistant properties found in a 19 x 7 rope — the 8 x 25 Resistwist rope has found successful application. The rotation-resistant characteristic is achieved by laying the eight outer strands around an independent wire rope core so these strands are in the opposite direction to the lay of the core. Thus, when the rope is in tension, opposing rotational forces are created between the core and outer strands.

Though not as rotation-resistant, the 8 x 25 Resistwist is more stable than a 19 x 7 rope. It also has increased resistance to bending, fatigue and crushing. This is achieved through the use of eight-strand construction with an independent wire rope core.

Like any application where an installation's rope type is changed, the 8 x 25 Resistwist rope should be substituted only after carefully comparing specifications and strength requirements.

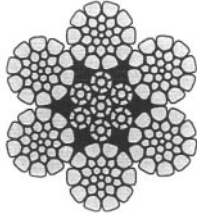
**Table 3-3. Nominal Strengths and Weights for Rotation-Resistant Crane Ropes**

Diameter (in.)	Flex-X® 19		19 x 7 XIP®		8 x 25 XXIP®	
	Approx. wt./ft. (lbs.)	Nominal Strength (Tons of 2,000 lbs.) ①	Approx wt./ft. (lbs.)	Nominal Strength (Tons of 2,000 lbs.) ①	Approx. wt./ft. (lbs.)	Nominal Strength (Tons of 2,000 lbs.) ①
3/16			0.064	1.57		
1/4			0.113	2.77		
5/16			0.177	4.30	0.18	4.63
3/8	0.31	8.3	0.25	6.15	0.26	6.63
7/16	0.40	11.2	0.35	8.33	0.36	8.97
1/2	0.54	14.6	0.45	10.8	0.47	11.6
9/16	0.69	18.5	0.58	13.6	0.60	14.7
5/8	0.85	22.7	0.71	16.8	0.73	18.1
3/4	1.25	32.4	1.02	24.0	1.06	25.9
7/8	1.68	43.8	1.39	32.5	1.44	35.0
1	2.17	56.9	1.82	42.2	1.88	45.5
1-1/8	2.75	71.5	2.30	53.1	2.39	57.3
1-1/4	3.45	87.9	2.83	65.1	2.94	70.5
1-3/8	4.33	106.0	3.43	78.4	3.56	84.9
1-1/2	5.11	125.0	4.08	92.8	4.24	100.0

① These strengths apply only when a test is conducted with both ends fixed. When in use, the strengths of these ropes may be significantly reduced if one end is free to rotate.

### Premium Value Ropes

#### Flex-X® 6 Wire Ropes

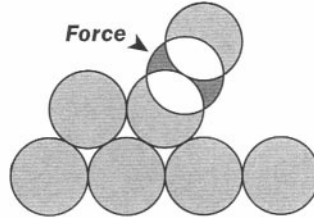


Flex-X 6

Most applications for wire rope are extremely demanding. Wire rope must resist crushing, bending fatigue and abrasion. For example, clamshell closing lines must resist bending fatigue and boom hoists are subject to pressures that cause crushing. Overhead hoists test that stability and strength of a wire rope. All drum-related applications demand a rope that will spool and operate smoothly and dependably.

Flex-X 6 users receive superior performance and increased service life in many applications compared to the ropes they had previously employed. When compared to conventional 6 strand ropes, Flex-X 6 ropes provide greater surface area and more steel per given diameter, which increases rope stability and strength, too. This results in longer service life and less sheave and drum wear.

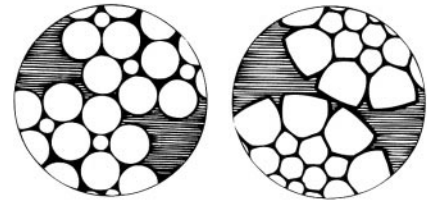
#### Flex-X vs. Standard 6 x 26 WS



Wire Contact of Flex-X

Drum scrubbing between the lead line and the previous wrap is reduced. The smooth contact creates less interference, less metal loss and wire deformation (above).

The increased surface area of Flex-X can be seen in the comparison of the contact points of a standard 6 x 26 WS (below left) and Flex-X (below right).



6 x 26 WS and Flex-X



**Table 3-4. Minimum Breaking Force and Weights for Flex-X 6 and Flex-X 9**

Diameter (in.)	Flex-X 6		Flex-X 9	
	Approximate wt./ft. (lbs.)	Minimum Breaking Force (Tons of 2,000 lbs.)	Approximate wt./ft. (lbs.)	Minimum Breaking Force (Tons of 2,000 lbs.)
3/8	0.32	8.8		
7/16	0.41	11.9		
1/2	0.55	15.3		
9/16	0.70	19.3		
5/8	0.86	22.7	0.95	26.2
3/4	1.25	32.4	1.35	37.4
7/8	1.67	43.8	1.85	50.6
1	2.18	56.9	2.40	65.7
1-1/8	2.71	71.5	3.05	82.7
1-1/4	3.43	87.9		
1-3/8	4.25	106.0		
1-1/2	5.01	125.0		

# WIRE ROPE

Amick Associates, Inc.

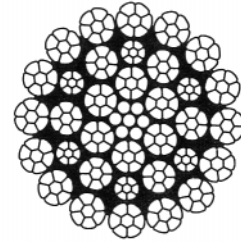
## Wire Rope Products

version #1-18

### "Compacted" Non-Rotating Ropes

Table 3-5. T/S: 195 kg/mm<sup>2</sup> equal to "EIPS - Grade"

Nominal Diameter		Minimum Breaking Strength			Approximate Weight	Maximum Length
(in.)	mm	lbs.	kg	kN	kg/m	m
1/2	12.0	27,600	12,520	123	0.74	4,000
	12.7	30,900	14,020	137	0.83	4,000
	13.0	32,400	14,690	144	0.87	3,000
9/16 5/8	14.0	37,500	17,040	167	1.01	3,000
	14.3	39,200	17,770	174	1.05	3,000
	16.0	49,000	22,250	218	1.32	2,000
3/4	18.0	62,100	28,160	276	1.67	2,000
	19.0	69,200	31,380	308	1.86	2,500
	20.0	76,000	34,770	341	2.06	2,500
7/8	22.0	92,700	42,070	413	2.47	2,500
	22.2	94,400	42,840	420	2.52	1,500
	24.0	110,400	50,070	491	2.94	1,500
1	25.0	119,800	54,330	533	3.21	1,500
	25.4	123,600	56,080	550	3.31	1,500
	26.0	129,500	58,760	576	3.43	1,500
1-1/8	28.0	150,200	68,150	668	3.98	1,500
	28.6	156,700	71,100	697	4.15	1,500
	30.0	172,500	78,230	767	4.63	1,300
1-1/4	31.8	193,800	87,900	862	5.20	1,100
	32.0	196,200	89,010	873	5.27	1,100
	34.0	221,500	100,480	985	5.94	1,000
1-3/8	35.0	234,800	106,480	1,044	6.31	900
	36.0	248,400	112,650	1,105	6.66	900



Construction: 35 x 7(WA) 1- 6- (6-WA6)-16

## Stainless Steel Cables

### Various Alloys Used

#### Stainless Steel (18-8 Grade)

Type 302 stainless steel is the standard alloy for cable. It has about the same strength as galvanized aircraft cable and much better corrosion resistance. It has excellent corrosion resistance in most industrial atmospheres, and good corrosion resistance in sea water and marine atmospheres. Type 302 also has very good corrosion resistance to many chemicals including nitric acid.

#### Type 305

Type 305 has better corrosion resistance than Type 302 with 10 – 15% lower strength. This alloy is primarily used for nonmagnetic cable applications. When sufficiently cold worked, this alloy does not become magnetic.

#### Type 316

Type 316 is the standard high corrosion resistant alloy for cable. It is resistant to many of the chemicals in the paper pulp, photographic, food processing and textile industries. It has the best pitting resistance in marine use of the commonly used stainless steels. The breaking strength is 10 – 15% below Type 302. Excellent. Excellent scale resistance allows its continuous use at temperatures up to 900 degrees F.

### Corrosion Resistance

Chromium in stainless steels is the primary reason for their corrosion resistance. The chrome protects the surface by quickly forming an impervious, tenacious oxide film. This acts as a protective barrier against attack. Nickel improves the oxide forming ability of chromium and also gives the stainless steel a broader range of corrosion resistance. Molybdenum improves the general corrosion resistance and specifically resistance to pitting attack in sea water.

### Why Type 302 is a Better Alloy for Making Cable

Type 302 and Type 304 are of the 18-8 grade (18% chromium, 8% nickel) of stainless steels. Strength can be developed in this grade by cold-working only. In the case of wire, drawing from a larger annealed size to a smaller size is the cold-working process. Because of its higher carbon content, Type 302 develops the required strength with less drawing and also enables it to resist fatigue better than Type 304.

The strength of cable depends not only on the strengths of the individual wires but on the ability of each wire to bear its share of the load. All the wires must be equally strong and each wire must be uniformly strong throughout its length. Our manufacturing practice produces wire of Type 302 with outstanding uniformity in strength and elongation properties. These properties are essential to long-lasting strength of a cable.

Of equal importance to strength is fatigue resistance. Type 304 has to be drawn farther to develop sufficient strength and is closer to the point of brittleness and less effective in resisting fatigue than Type 302.

In some forms and conditions in which these alloys are used, Type 304 with its lower carbon content, could have equal or better corrosive resistance than an extremely high carbon Type 302. In the form of hard-drawn wire for cable, however, the structure of the Type 304 alloy may be under such severe internal stress that it becomes more susceptible to chemical attack; for example, by sea water. Our controlled carbon content Type 302 stainless steel wire in its relaxed condition offers greater resistance to corrosion. All of these features of our Type 302 stainless steel cable lead to broader applications for its use. The user will gain efficiency and economy from our high performance Type 303 stainless steel cables.

**Table 3-6. Preformed — IWRC Stainless Steel — Type 316**

Diameter (in.)	Breaking Strength Pounds	Weight Pounds M Feet
<b>6 x 19</b>		
7/16	15,000	356.0
1/2	19,300	458.0
5/8	29,800	715.0
<b>7 x 7</b>		
3/64	240	4.2
1/16	360	7.5
3/32	700	16.0
1/8	1,360	28.5
<b>7 x 19</b>		
1/8	1,300	29.0
5/32	2,000	45.0
3/16	2,900	65.0
1/4	4,900	110.0
5/16	7,600	173.0
3/8	11,000	243.0

**Table 3-7. Annealed Stainless Steel Seizing Strand**

Diameter (in.)	Breaking Strength Pounds	Weight Pounds M Feet
<b>1 x 7</b>		
1/32	60	2.3
3/64	130	5.3
1/16	230	8.5
5/64	360	14.0
3/32	500	20.0
1/8	900	33.0
5/32	1,350	50.0

**Table 3-8. Preformed — Stainless Steel Strand — Type 302**

Diameter (in.)	Breaking Strength Pounds	Weight Pounds M Feet
<b>1 x 7</b>		
.012	25	0.33
.015	40	0.55
.018	55	0.73
.021	80	1.00
.024	100	1.30
.027	125	1.70
1/32	185	2.30
.038	250	3.50
3/64	375	5.50
1/16	500	8.50
5/64	800	14.00
3/32	1,200	20.00
7/64	1,600	27.00
1/8	2,100	35.00
5/32	3,300	55.00
3/16	4,700	77.00
7/32	6,300	103.00
1/4	8,500	135.00

# WIRE ROPE

## Stainless Steel Cables

**Table 3-8. (Continued) Preformed — Stainless Steel Strand — Type 302**

Diameter (in.)	Breaking Strength Pounds	Weight Pounds M Feet
<b>1 x 7 (Continued)</b>		
9/32	10,700	170.0
5/16	13,200	212.0
3/8	18,000	282.0
7/16	26,000	416.0
1/2	33,700	535.0

**1 x 19**

1/32	185	2.5
3/64	335	5.5
1/16	500	8.5
5/64	800	14.0
3/32	1,200	20.0
7/64	1,600	27.0
1/8	2,100	35.0
5/32	3,300	55.0
3/16	4,700	77.0
7/32	6,300	102.0
1/4	8,200	135.0
9/32	10,300	170.0
5/16	12,500	210.0
3/8	17,500	300.0
7/16	22,500	410.0
1/2	30,000	521.0
9/16	36,200	670.0
5/8	47,000	855.0

**3 x 3**

.021	40	0.5
------	----	-----

**3 x 7**

1/32	110	1.7
5/64	650	9.7

**6 x 19 IWRC**

7/16	16,300	356.0
1/2	22,800	458.0
9/16	28,500	590.0
5/8	35,000	715.0
3/4	49,600	922.0
7/8	66,500	1,430.0
1	85,400	1,870.0
1-1/8	106,400	2,400.0
1-1/4	129,400	2,900.0

**6 x 37 IWRC**

3/16	3,000	65.0
1/4	5,400	100.0
5/16	8,300	180.0
3/8	11,700	240.0
7/16	15,800	330.0
1/2	20,800	430.0
9/16	25,600	540.0
5/8	31,400	670.0
3/4	44,400	960.0
7/8	59,700	1,310.0
1	77,300	1,700.0
1-1/8	96,600	2,160.0
1-1/4	118,400	2,660.0

**Table 3-8. (Continued) Preformed — Stainless Steel Strand — Type 302**

Diameter (in.)	Breaking Strength Pounds	Weight Pounds M Feet
----------------	--------------------------	----------------------

**6 x 42 Non-Preformed**

1/8	700	18.0
3/16	1,600	40.0
1/4	3,200	70.0
5/16	4,900	110.0
3/8	6,900	160.0
7/16	9,300	210.0
1/2	12,000	280.0
9/16	15,000	350.0
5/8	18,400	430.0

**7 x 3**

.018	40	0.5
.024	60	1.0
.031	110	1.7

**7 x 7**

.031	115	2.0
3/64	270	4.2
1/16	480	7.5
5/64	650	11.0
3/32	920	16.0
7/64	1,260	22.0

1/8	1,700	28.5
5/32	2,400	43.0
3/16	3,700	62.0
7/32	5,000	83.0
1/4	6,400	106.0
9/32	7,800	134.0
5/16	9,000	167.0
3/8	12,000	236.0
7/16	15,600	342.0
1/2	21,300	440.0
9/16	26,600	550.0
5/8	32,500	680.0
3/4	46,000	970.0

**7 x 19**

3/64	270	4.2
1/16	480	7.5
3/32	920	16.0
7/64	1,260	22.0
1/8	1,760	29.0
5/32	2,400	45.0
3/16	3,700	65.0
7/32	5,000	86.0
1/4	6,400	110.0
9/32	7,800	139.0
5/16	9,000	173.0
3/8	12,000	243.0

**19 x 7 Non-Rotating**

1/8	1,500	29.0
5/32	2,160	45.0
3/16	3,330	65.0
7/32	4,500	86.0
1/4	5,760	110.0
5/16	8,100	173.0
3/8	10,800	243.0
7/16	13,800	356.0
1/2	20,520	458.0
9/16	24,200	590.0
5/8	31,500	715.0

**Table 3-9. Preformed — IWRC Stainless Steel Strand — Type 305**

Diameter (in.)	Breaking Strength Pounds	Weight Pounds M Feet
----------------	--------------------------	----------------------

**6 x 19 Non-Magnetic**

7/16	14,900	356.0
1/2	19,300	458.0
9/16	24,300	590.0
5/8	30,100	715.0
3/4	42,900	1,052.0
7/8	58,000	1,430.0
1	75,200	1,870.0

**7 x 7**

1/16	360	7.5
3/32	700	16.0

**7 x 19**

1/8	1,300	29.0
5/32	2,000	45.0
3/16	2,900	65.0
7/32	3,800	86.0
1/4	4,900	110.0
9/32	6,100	139.0
5/16	7,600	173.0
3/8	11,000	243.0

**Table 3-10. Preformed — IWRC Stainless Steel Strand — Type 305**

Diameter (in.)	Breaking Strength Pounds	Weight Pounds M Feet
----------------	--------------------------	----------------------

**1 x 7**

7/32	5,700	103.0
1/4	7,650	135.0
9/32	9,650	170.0
5/16	11,900	212.0
3/8	16,200	282.0
7/16	23,400	416.0
1/2	30,200	535.0

**1 x 19**

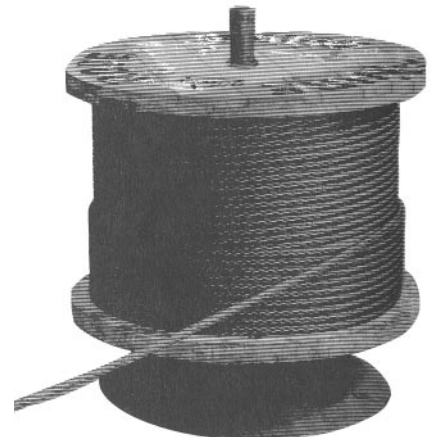
1/8	1,780	35.0
5/32	2,800	55.0
3/16	4,000	77.0
7/32	5,350	102.0
1/4	6,900	135.0
9/32	9,400	170.0
5/16	10,600	210.0
3/8	14,800	300.0
7/16	20,000	410.0
1/2	27,000	521.0
9/16	32,400	670.0
5/8	42,000	855.0

### Proper Wire Rope Use

#### Unreeling and Uncoiling

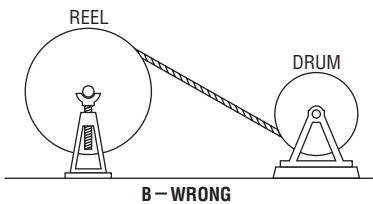
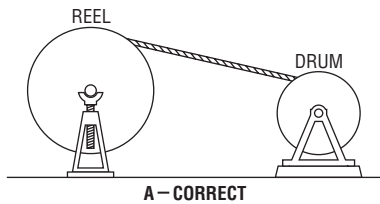


The wire rope reel is mounted on a shaft supported by jacks. This permits the reel to rotate freely, and the rope can be unwound either manually or by a powered mechanism.



A vertical unreeling stand.

3



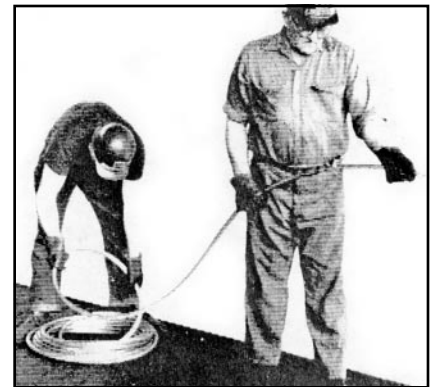
The correct (A) and the wrong (B) way to wind wire rope from reel to drum.



Perhaps the most common and easiest uncoiling method is to hold one end of the rope while the coil is rolled along the ground.



Illustrating a wrong method of unreeling wire rope.



Illustrating a wrong method of uncoiling rope.

# WIRE ROPE

Amick Associates, Inc.

## Proper Wire Rope Use

version #1-18

### Winding Wire Rope

Invariably in winding wire rope onto a shipping reel or a cooling drum, the rope is wound over the top of the reel or drum. The fact that the rope comes from under the stock reel to wind reversely on top of the shipping reel has no effect on the physical condition of the rope, provided the stock reel is set at least 20 feet, or preferably more, from the rewinding machine.

The rope should be wound “thread lay,” with close even winding throughout the length of the rope. If wound unevenly, the turns of rope bunch up, cross wind and are liable to form doglegs, particularly on the more flexible ropes.

Never fill the reel full to the rim or edge of the flanges. If possible, leave a clearance equivalent to at least two layers of rope. This will save injury to the rope when the reel is rolled over obstructions on the ground.

### Installing Rope on Drums

The manner in which wire rope is installed or wound on a drum will, to a large measure, determine the service life of the rope. Improperly wound ropes will cause undue crushing of the rope, doglegs, kinks, excessive abrasion and cutting of the individual wires. Bad spooling also causes uneven application of force and motion. This results in fast fatiguing of the line from the end attachment to the drum.

There are five precautionary steps that should be taken before starting the actual winding of the rope off the coil or shipping reel.

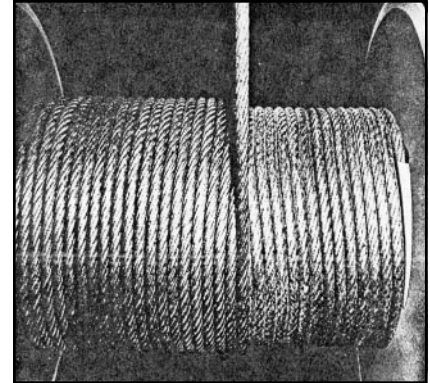
1. A check should be made of the drum to determine the condition, size and shape of the grooves. If the drum is a smooth type, then the surface should be checked for straightness and smoothness.
2. Flanges should be checked to determine the extent of undercutting at the base.
3. Dirt, grit, filled grease or any other type of debris should be cleaned off.
4. Bearings should be checked.
5. Cracks or breaks in segments of the drum should be reported.

Whenever any of these five conditions are observed, the equipment should be removed from service and properly cleaned, repaired or replaced. This recommendation is made not alone to improve or maintain good rope life, but to eliminate a potential hazard.

After establishing the satisfactory condition of the drum, the shipping reel is mounted on suitable jacks. The end is attached to the drum using the attachment provided. A tension should be induced into the line by providing some means of braking the shipping reel. A tight winding is imperative, particularly if multiple layer winding is required.

When winding a rope onto a grooved drum, the groove will properly guide the rope. If the rope is to be rewound on a smooth drum, then a helper should guide the rope, making sure each turn is winding tightly against the adjacent turn.

A lead or brass hammer is useful in tapping the line over as it is being wound. Do not use a steelhead hammer or pinch bars. These can readily cause damage to the lines.



3

### Inspection of Sheaves and Drums

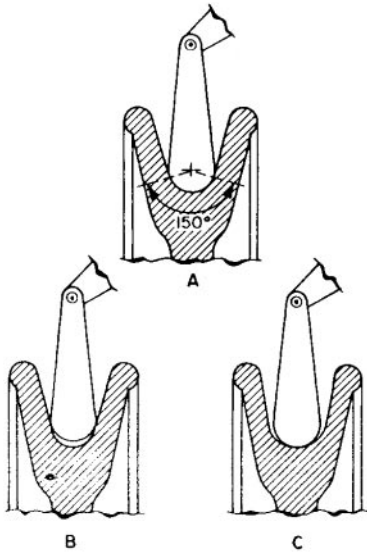
Under normal conditions, machines receive periodic inspections, and their overall condition is recorded. Such inspections usually include the drum, sheaves, and other parts that may come into contact with the wire rope and subject it to wear. As an additional precaution, rope-related working parts, particularly in the areas described below, should be re-inspected prior to the installation of a new wire rope.

The very first item to be checked when examining sheaves and drums, is the condition of the grooves. To check the size, contour and amount of wear, a groove gage is used. As shown in the figure to the left, the gage should contact the groove for about 150° of arc.

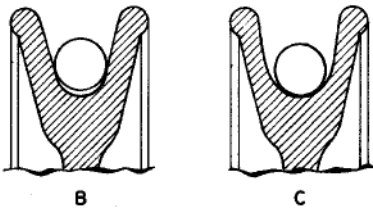
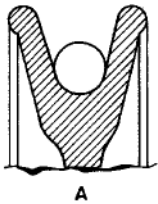
Two types of groove gages are in general use and it is important to note which of these is being used. The two differ by their respective percentage over nominal.

For new or re-machined grooves, the groove gage is nominal plus the full oversize percentage. The gage carried by most wire rope representatives today is used for worn grooves and is made nominal plus half the oversize percentage.

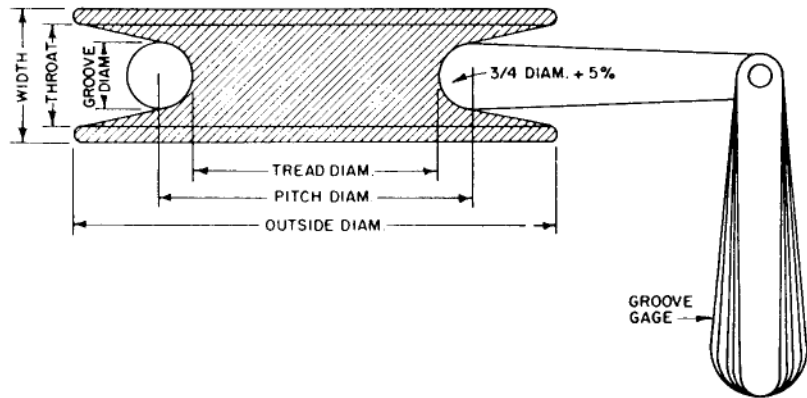
This latter gage is intended to act as a sort of "no-go" gage. Any sheave with a groove smaller than this must be re-grooved or, in all likelihood, the existing rope will be damaged.



**Cross-sections illustrating three sheave-groove conditions. A is correct, B is too tight, and C is too loose.**



**These sheave-groove cross-sections represent three wire rope seating conditions: A, a new rope in a new groove; B, a new rope in a worn groove; and C, a worn rope in a worn groove.**



**Illustrating the various dimensions of a sheave, and the use of a groove gage.**

## Proper Wire Rope Use

### Wire Rope Inspection

All wire ropes will wear out eventually and gradually lose work capability throughout their service life. That's why periodic inspections are critical. Applicable industry standards such as ASME B30.2 for overhead and gantry cranes or federal regulations such as OSHA refer to specific inspection criteria for varied applications.

### Three Purposes for Inspection

Regular inspection of wire rope and equipment should be performed for three good reasons:

1. It reveals the rope's condition and indicates the need for replacement.
2. It can indicate if you're using the most suitable type of rope.
3. It makes possible the discovery and correction of faults in equipment or operation that can cause costly accelerated rope wear.

### How Often

All wire ropes should be thoroughly inspected at regular intervals. The longer it has been in service or the more severe the service, the more thoroughly and frequently it should be inspected. Be sure to maintain records of each inspection.

### Appoint a Qualified Person to Inspect

Inspections should be carried out by a person who has learned through special training or practical experience what to look for and who knows how to judge the importance of any abnormal conditions they may discover. It is the inspector's responsibility to obtain and follow the proper inspection criteria for each application inspected.

- One outer wire broken at the contact point with the core of the rope which has worked its way out of the rope structure and protrudes or loops out from the rope structure.
- Wear of one-third the original diameter of outside individual wires.
- Kinking, crushing, birdcaging, or any other damage resulting in distortion of the rope structure.
- Evidence of any heat damage from any cause.
- Valley breaks.
- Reductions from nominal rope diameter of more than the rope diameters listed below.

**Table 3-11. Reduction of Nominal Rope Diameters**

Reduction (in.)	Nominal Rope Diameter (in.)
1/64	Up to & including 5/16
1/32	Over 5/16 thru 1/2
3/64	Over 1/2 thru 3/4
1/16	Over 3/4 thru 1-1/8
3/32	Over 1-1/8

- In standing ropes, more than two broken wires in one lay in section beyond end connections or more than one broken wire at an end connection.

Replacement rope shall have a strength rating at least as great as the original rope furnished by the equipment manufacturer or as originally specified. Any deviation from the original size, grade, or construction shall be specified by the equipment manufacturer, original design engineer, or a qualified person.

### Ropes Not in Regular Use

All rope which has been idle for a period of a month or more due to shutdown or storage of equipment on which it is installed should be given inspections as previously described before being placed in service. This inspection should be for all types of deterioration and should be performed by an appointed or authorized person.

### What to Look For

Here's what happens when a wire breaks under tensile load exceeding its strength. It's typically recognized by the "cup and cone" appearance at the point of failure. The necking down of the wire at the point of failure to form the cup and cone indicates failure has occurred while the wire retained its ductility.

This is a wire with a distinct **fatigue break**. It's recognized by the **square end** perpendicular to the wire. This break was produced by a torsion machine that's used to measure the ductility. This break is similar to wire failures in the field caused by fatigue.

A wire rope that has been subjected to repeated bending over sheaves under normal loads. This results in **fatigue breaks** in individual wires — these breaks are square and usually in the crown of the strands.

An example of **fatigue failure** of a wire rope subjected to heavy loads over small sheaves. The breaks in the valleys of the strands are caused by "strand nicking." There may be crown breaks, too.

Here you see a single strand removed from a wire rope subjected to "**strand nicking**." This condition is a result of adjacent strands rubbing against one another. While this is normal in a rope's operation, the nicking can be accentuated by high loads, small sheaves or loss of core support. The ultimate result will be individual wire breaks in the valleys of the strands.

### Inspection Records

Frequent Inspection — no records required.

Periodic Inspection: In order to establish data as a basis for judging the proper time for replacement a signed report of rope condition at each periodic inspection should be kept on file. This report should include points of deterioration previously described.

A long range inspection program should be established and include records of examination of ropes removed from service so a relation can be established between visual observation and actual condition of the internal structure.



### Typical Evidence of Wear and Abuse

A “**birdcage**” is caused by sudden release of tension and the resulting rebound of rope. These strands and wires will not be returned to their original positions. The rope should be replaced immediately.



A typical failure of a rotary drill line with a poor cutoff practice. These wires have been subjected to continued **peening**, causing fatigue type failures. A predetermined, regularly scheduled cutoff practice can help eliminate this type of problem.



This is **localized wear** over an equalized sheave. The danger here is that it's invisible during the rope's operation, and that's why you need to inspect this portion of an operating rope regularly. The rope should be pulled off the sheave during inspection and bent to check for broken wires.



This is a wire rope with a **high strand** — a condition in which one or more strands are worn before adjoining strands. This is caused by improper socketing or seizing, kinks or doglegs. At top, you see a closeup of the concentration of wear. At bottom, you see how it recurs every sixth strand in a six strand rope.



A **kinked wire rope** is shown here. It's caused by pulling down a loop in a slack line during handling, installation or operation. Note the distortion of the strands and individual wires. This rope must be replaced.



Here's a wire rope that has jumped a sheave. The rope “**curled**” as it went over the edge of the sheave. When you study the wires, you'll see two types of breaks here: tensile “cup and cone” breaks and shear breaks that appear to have been cut on an angle.



**Drum crushing** is caused by small drums, high loads and multiple winding conditions.



### Removal Criteria

A major portion of any wire rope inspection is the detection of broken wires. The number and type of broken wires are an indication of the rope's general condition and a benchmark for its replacement.

Frequent inspections and written records help determine the rate at which wires are breaking. Replace the rope when the values given in the table below are reached.

Valley wire breaks — where the wire fractions between strands or a broken wire protrudes between strands — are treated differently than those that occur on the outer surface of the rope. When there is more than one valley break, replace the rope.

Broken wire removal criteria cited in many standards and specifications, like those listed below, apply to wire ropes operating on steel sheaves and drums. For wire ropes operating on sheaves and drums with material other than steel, please contact the sheave, drum or equipment manufacturer or a qualified person for proper broken wire removal criteria.



**Table 3-12. When to Replace Wire Rope — Based on Number of Wires**

Standard	Equipment	Number of Broken Wires in Running Ropes			Number of Broken Wires in Standing Ropes		
		In One Rope Lay	In One Strand	At End Connection	In One Rope Lay	At End Connection	
ASME/B30.2	Overhead and Gantry Cranes	12 ①	4	Not Specified	Not Specified		
ASME/B30.4	Portal, Tower and Pillar Cranes	6 ①	3	2	3	2	
ASME/B30.5	Mobile and Locomotive Cranes	Running Ropes	6 ①	3	2	3	2
		Rotation-resistant Ropes	2 Randomly Distributed Broken Wires in 6 Rope Diameters or 4 Randomly Distributed Broken Wires in 30 Rope Diameters ①				
ASME/B30.6	Derricks	6 ①	3	2	3	2	
ASME/B30.7	Base-mounted Drum Hoists	6 ①	3	2	3	2	
ASME/B30.8	Floating Cranes and Derricks	6 ①	3	2	3	2	
ASME/b30.16	Overhead Hoists	12 ①	4	Not Specified	Not Specified		
ANSI/A10.4	Personnel Hoists	6 ①	3	2	2 ①	2	
ANSI/A10.5	Material Hoists	6 ①	Not Specified		Not Specified		

① Also remove for one valley break.

# WIRE ROPE

Amick Associates, Inc.

## Proper Wire Rope Use

version #1-18

### Attaching Clips

A termination made in accordance with the instructions and using the number of clips shown has an approximate 80% efficiency rating. This rating is based upon the catalog breaking strength of wire rope. If a pulley is used in place of a thimble for turning back the rope, add one additional clip.

The number of clips shown is based upon using right regular or lang lay wire rope, 6 x 19 class or 6 x 37 class, fiber core or IWRC, improved plow or extra improved plow. If Seale construction or similar large outer wire construction in the 6 x 19 class is to be used for sizes 1 inch and larger, add one additional clip.

The number of clips shown also applies to right regular lay wire rope, 8 x 19 class, fiber core, improved plow, sizes 1-1/2 inches and smaller; and right regular lay wire rope, 19 x 7 class, improved plow or extra improved plow, sizes 1-3/4 inches and smaller.

For other classes of wire rope not mentioned above, it may be necessary to add additional clips to the number shown.

### Suggested Method of Applying Clips to Get Maximum Holding Power

1. Turn back the specified amount of rope from the thimble. Apply the first clip one base width from the dead end of the wire rope (U-bolt over dead end — live end rests in clip saddle). Tighten nuts evenly to suggested torque.
2. Apply the next clip as near the loop as possible. Turn nuts firm but do not tighten.
3. Space additional clips, if required, equally between the first two. Turn nuts — take up rope slack — tighten all nuts evenly on all clips to suggested torque.
4. **Notice:** Apply the initial load and retighten nuts to the suggested torque. Rope will stretch and shrink in diameter when loads are applied. Inspect periodically and tighten.

**Important:** Failure to make a termination in accordance with aforementioned instruction or failure to periodically check and retighten to the suggested torque will cause a reduction in aforementioned efficiency rating.



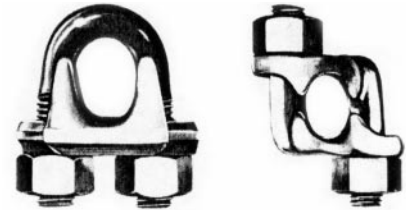
**RIGHT WAY for Maximum Rope Strength**



**WRONG WAY: Clips Staggered**



**WRONG WAY: Clips Reversed**



**Wire Rope Clips**

**Table 3-13. Number of Clips Suggested**

Clip Size (in.)	Minimum Number of Clips	Amount of Rope to Turn Back (in.)	Torque in ft. lbs.
1/8	2	3-1/4	4.5
3/16	2	3-3/4	7.5
1/4	2	4-3/4	15
5/16	2	5-1/4	30
3/8	2	6-1/2	45
7/16	2	7	65
1/2	3	11-1/2	65
9/16	3	12	95
5/8	3	12	95
3/4	4	18	130
7/8	4	19	225
1	5	26	225
1-1/8	6	34	225
1-1/4	6	37	360
1-3/8	7	44	360
1-1/2	7	48	360
1-5/8	7	51	430
1-3/4	7	53	590
2	8	71	750
2-1/4	8	73	750
2-1/2	9	84	750
2-3/4	10	100	750
3	10	106	1,200

**Note:** If a greater number of clips are used than shown in the table, the amount of rope turnback should be increased proportionately.

**Note:** Tabular data concerning Wire Rope Clips, courtesy of The Crosby Group, Division of American Hoist & Derrick Co., Tulsa, Oklahoma.

### Press-Grip Slings

#### Type U-1 (Mechanical Splice)

Type U-1 is a general purpose sling. It is adaptable for basket and straight pull hitches. This type of sling is used more widely than any other type for general material handling.

**Table 3-14. 6 x 19 & 6 x 37 Type XIP, IWRC ①**

Rope Size (in.)	Eye Size (in.)		Recommended Minimum Length	Rated Capacity (Tons 2,000 lbs.) ②					
	W	L		Straight Pull	Choker Hitch	Basket Hitch — Horizontal			
						90°	60°	45°	30°
1/4	3	6	1'6"	0.65	0.48	1.3	1.1	0.91	0.65
5/16	3	6	1'10"	1.0	0.74	2.0	1.7	1.4	1.0
3/8	3	6	1'10"	1.4	1.1	2.9	2.5	2.0	1.4
7/16	4	8	2'4"	1.9	1.4	3.9	3.4	2.7	1.9
1/2	4	8	2'6"	2.5	1.9	5.1	4.4	3.6	2.5
9/16	4	8	2'8"	3.2	2.4	6.4	5.5	4.5	3.2
5/8	5	10	3'2"	3.9	2.9	7.8	6.8	5.5	3.9
3/4	6	12	3'8"	5.6	4.1	11.0	9.7	7.9	5.6
7/8	7	14	4'4"	7.6	5.6	15.0	13.0	11.0	7.6
1	8	16	4'10"	9.8	7.2	20.0	17.0	14.0	9.8
1-1/8	9	18	5'6"	12.0	9.1	24.0	21.0	17.0	12.0
1-1/4 ③	10	20	6'2"	15.0	11.0	30.0	26.0	21.0	15.0
1-3/8 ③	11	22	6'10"	18.0	13.0	36.0	31.0	25.0	18.0
1-1/2 ③	12	24	7'4"	21.0	16.0	42.0	37.0	30.0	21.0
1-3/4 ③	14	28	8'6"	28.0	21.0	57.0	49.0	40.0	28.0
2 ③	16	32	9'10"	37.0	28.0	73.0	63.0	52.0	37.0

① XXIP Slings are 10% stronger than XIP.

② Rated loads are based on a diameter of curvature of 20 times the individual rope diameter at points of sling contact with load.

③ 6 x 37 Type only.

#### Type U-3 (Mechanical Splice)

Type U-3 is recommended for handling pipe, bundles, bars, castings, lumber - for any type of load that lends itself to a choker hitch. The sliding hook is of high strength steel with rounded saddle to minimize wear on the rope when choked. Hitches quickly and holds tight.

**Table 3-15. 6 x 19 & 6 x 37 Type XIP, IWRC ①**

Rope Size (in.)	Eye Size (in.)		Recommended Minimum Length	Rated Capacity (Tons 2,000 lbs.) ②	Fittings		
	W	L			Choker Hitch	Sliding Hook	Wire Rope Thimble
1/4	3	6	2'	0.48		1/4 - 5/16	1/4
5/16	3	6	2'	0.74		1/4 - 5/16	5/16
3/8	3	6	2'6"	1.1		3/8	3/8
7/16	4	8	2'6"	1.4		1/2	7/16
1/2	4	8	2'6"	1.9		1/2	1/2
9/16	4	8	3'	2.4		5/8	9/16
5/8	5	10	3'6"	2.9		5/8	5/8
3/4	6	12	3'6"	4.1		3/4	3/4
7/8	7	14	4'6"	5.6		7/8 - 1	7/8
1	8	16	5'	7.2		7/8 - 1	1
1-1/8	9	18	5'	9.1		1-1/8 - 1-1/4	1-1/8
1-1/4 ③	10	20	6'	11.0		1-1/8 - 1-1/4	1-3/8
1-3/8 ③	11	22	7'	13.0		1-3/8 - 1-1/2	1-3/8
1-1/2 ③	12	24	7'	16.0		1-3/8 - 1-1/2	1-1/2

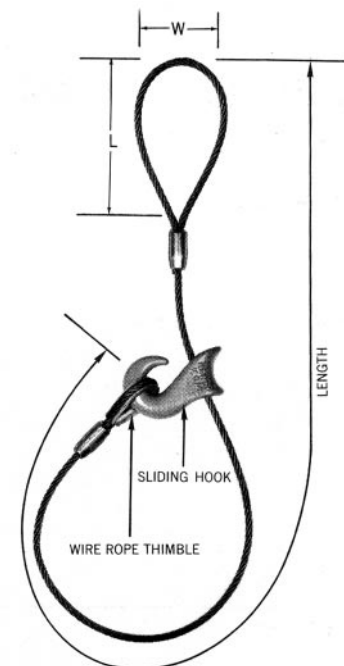
① XXIP Slings are 10% stronger than XIP.

② Rated loads are based on a diameter of curvature of 20 times the individual rope diameter at point of sling contact with load.

③ 6 x 37 Type only.



**Press-Grip Sling / Type U-1**



**Press-Grip Sling / Type U-3**

# WIRE ROPE

## Press-Grip Slings

### Type U-4 (Mechanical Splice)

□ choker sling □ t h o legs. Each leg has a sliding hook and the top eye is spliced in to an oblong or pear shaped link. This type of sling eliminates load rotations and is better suited for handling pipe, bar stock, timber, tanks, castings, and other loads that run in longer lengths.

Table 3-16. 6 x 19 & 6 x 37 Type XIP, IWRC ①

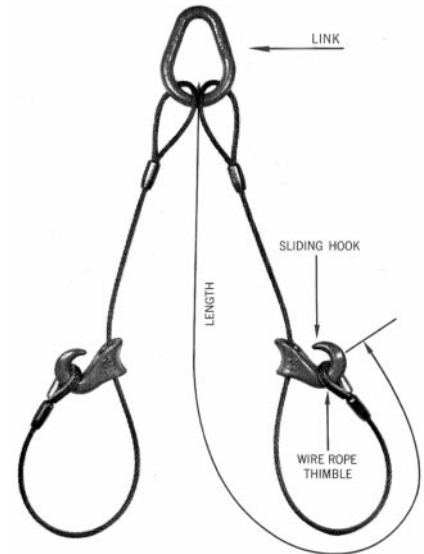
Rope Size (in.)	Recommended Minimum Length	Rated Capacity (Tons 2,000 lbs.) — Horizontal ②		Fittings		
		60°	30°	Sliding Hook (2 Req'd)	Wire Rope Thimble (2 Req'd)	Link ③
1/4	2'	0.82	0.48	1/4 – 5/16	1/4	L-0
5/16	2'	1.3	0.74	1/4 – 5/16	5/16	L-0
3/8	2'6"	1.8	1.1	3/8	3/8	L-1
7/16	2'6"	2.5	1.4	1/2	7/16	L-2
1/2	2'6"	3.2	1.9	1/2	1/2	L-3
9/16	3'	4.1	2.4	5/8	5/8	L-3
5/8	3'6"	5.0	2.9	5/8	5/8	L-4
3/4	3'6"	7.1	4.1	3/4	3/4	L-5
7/8	4'6"	9.7	5.6	7/8 – 1	7/8	L-10
1	5'	13.0	7.2	7/8 – 1	1	L-12
1-1/8	5'	16.0	9.1	1-1/8 – 1-1/4	1-1/8	L-13
1-1/4 ④	6'	19.0	11.0	1-1/8 – 1-1/4	1-1/4	L-13
1-3/8 ④	7'	23.0	13.0	1-3/8 – 1-1/2	1-3/8	L-13
1-1/2 ④	7'	28.0	16.0	1-3/8 – 1-1/2	1-1/2	L-14 (L-15)

① XXIP strength slings are 10% stronger than XIP.

② Rated loads are based on a diameter of curvature of 20 times the individual rope diameter at points of sling contact with load.

③ Links in parentheses are needed for adequate space when thimbles are used in the sling eyes at the link.

④ 6 x 37 Type only.



Press-Grip Sling/Type U-4

### Type U-6 (Mechanical Splice)

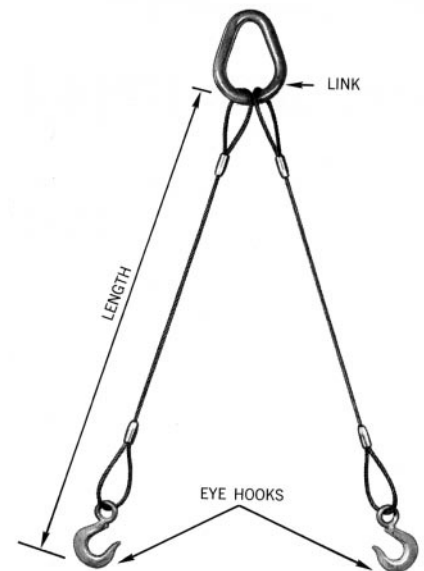
Type U-6 is one of the most popular two-legged slings. Eyes are spliced into an oblong or pear shaped link, with the other ends spliced into eye hooks. Efficient for such applications as lifting machinery, castings, motors, and aircraft assemblies.

Table 3-17. 6 x 19 & 6 x 37 Type XIP, IWRC ①

Rope Size (in.)	Recommended Minimum Length	Rated Capacity (Tons 2,000 lbs.) — Horizontal				Fittings	
		90°	60°	45°	30°	Eye Hook	Link
1/4	1'6"	1.3	1.1	0.91	0.65	22	L-0
5/16	1'8"	2.0	1.7	1.4	1.0	23	L-1
3/8	1'10"	2.9	2.5	2.0	1.4	24	L-2
7/16	2'4"	3.9	3.4	2.7	1.9	25	L-3
1/2	2'6"	5.1	4.4	3.6	2.5	26	L-4
9/16	2'10"	6.4	5.5	4.5	3.2	27	L-5
5/8	3'4"	7.8	6.8	5.5	3.9	28	L-5
3/4	3'8"	11.0	9.7	7.9	5.6	29	L-10
7/8	4'4"	15.0	13.0	11.0	7.6	31	L-12
1	5'	20.0	17.0	14.0	9.8	32	L-13
1-1/8	5'10"	24.0	21.0	17.0	12.0	33	L-13
1-1/4 ②	6'6"	30.0	26.0	21.0	15.0	34	L-14
1-3/8 ②	7'	36.0	31.0	25.0	18.0	35	L-16
1-1/2 ②	7'6"	42.0	37.0	30.0	21.0	35	L-17
1-3/4 ②	9'2"	57.0	49.0	40.0	28.0	36	L-18

① XXIP strength slings are 10% stronger than XIP.

② 6 x 37 Type only.



Press-Grip Sling/Type U-6

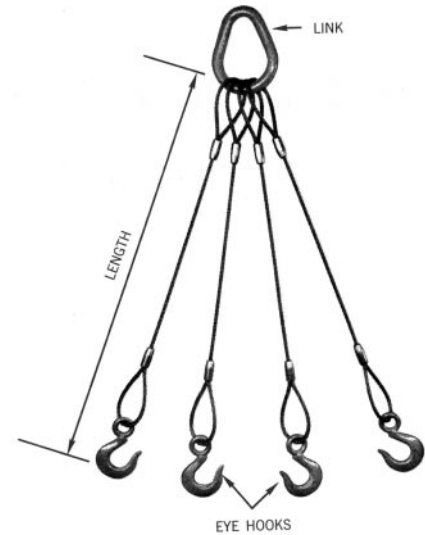
### Type U-8 (Mechanical Splice)

Here's extra stability for heavy, bulky loads. Ideal for ship sections, planer beds, foundry molds, pressure vessel manholes, and similar loads. Eyes are spliced into oblong or pear shaped links, and the other ends are spliced into eye hooks.

**Table 3-18. 6 x 19 & 6 x 37 Type XIP, IWRC ①**

Rope Size (in.)	Recommended Minimum Length	Rated Capacity (Tons 2,000 lbs.) — Horizontal				Fittings	
		90°	60°	45°	30°	Eye Hook	Link ②
1/4	1'6"	2.6	2.2	1.8	1.3	22	L-2
5/16	1'8"	4.0	3.5	2.8	2.0	23	L-3
3/8	1'10"	5.7	5.0	4.1	2.9	24	L-4
7/16	2'4"	7.8	6.7	5.5	3.9	25	L-5 ③
1/2	2'6"	10.0	8.8	7.1	5.1	26	L-10
9/16	2'10"	13.0	11.0	9.0	6.4	27	L-10 (L-11)
5/8	3'4"	16.0	14.0	11.0	7.8	28	L-12
3/4	3'8"	22.0	19.0	16.0	11.0	29	L-13
7/8	4'4"	30.0	26.0	21.0	15.0	31	L-14 (L-15)
1	5'	39.0	34.0	28.0	20.0	32	L-16 (L-17)
1-1/8	5'10"	48.0	42.0	34.0	24.0	33	L-18 (L-19)
1-1/4 ⑤	6'6"	59.0	51.0	42.0	30.0	34	L-20 (L-23) ④
1-3/8 ⑤	7'	71.0	62.0	50.0	36.0	35	L-20 (L-25)
1-1/2 ⑤	7'6"	84.0	73.0	60.0	42.0	35	L-22 (L-25)

- ① XXIP strength slings are 10% stronger than XIP.
- ② Links in parentheses are needed for adequate space when thimbles are used in the sling eyes at the link.
- ③ If thimbles are used, use 1/2" thimbles.
- ④ If thimbles are used, use 1-3/8" thimbles.
- ⑤ 6 x 37 Type only.



**Press-Grip Sling/Type U-8**

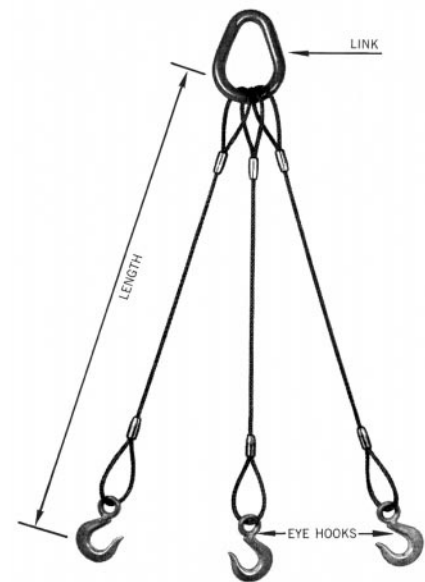
### Type U-9 (Mechanical Splice)

Type U-9 is a three-leg bridle sling. It gives sure balance when lifting heavy materials such as dies, castings, and assemblies that must be lifted and placed carefully - sometimes in difficult locations. Eyes are spliced into an oblong or pear shaped link, the other end into eye hooks.

**Table 3-19. 6 x 19 & 6 x 37 Type XIP, IWRC ①**

Component Part Size (in.)	Recommended Minimum Length	Rated Capacity (Tons 2,000 lbs.) — Horizontal				Fittings	
		90°	60°	45°	30°	Eye Hook	Link ②
1/4	1'6"	1.9	1.7	1.4	0.97	22	L-1
5/16	1'8"	3.0	2.6	2.1	1.5	23	L-2
3/8	1'10"	4.3	3.7	3.0	2.2	24	L-3
7/16	2'4"	5.8	5.0	4.1	2.9	25	L-4
1/2	2'6"	7.6	6.6	5.4	3.8	26	L-5
9/16	2'10"	9.6	8.3	6.8	4.8	27	L-5
5/8	3'4"	12.0	10.0	8.3	5.9	28	L-10
3/4	3'8"	17.0	15.0	12.0	8.4	29	L-12
7/8	4'4"	23.0	20.0	16.0	11.0	31	L-13
1	5'	29.0	26.0	21.0	15.0	32	L-14
1-1/8	5'10"	36.0	31.0	26.0	18.0	33	L-16
1-1/4 ③	6'6"	44.0	38.0	31.0	22.0	34	L-18
1-3/8 ③	7'	53.0	46.0	38.0	27.0	35	L-18 (L-22)
1-1/2 ③	7'6"	63.0	55.0	45.0	32.0	35	L-20 (L-23)
1-3/4 ③	9'2"	85.0	74.0	60.0	42.0	36	L-22 (L-24)

- ① XXIP strength slings are 10% stronger than XIP.
- ② Links in parentheses are needed for adequate space when thimbles are used in the sling eyes at the link.
- ③ 6 x 37 Type only.



**Press-Grip Sling/Type U-9**

# WIRE ROPE

## Grommet Slings

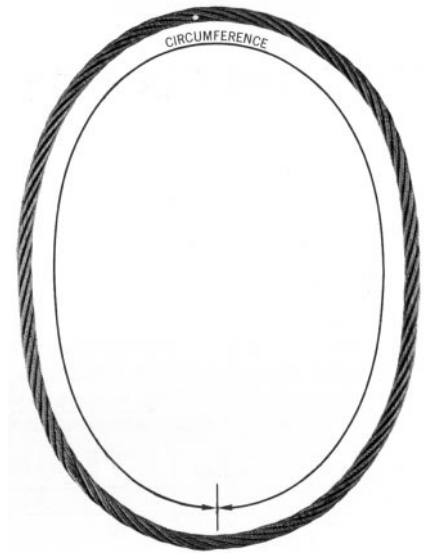
### Grommet Slings

Grommet Slings can be fabricated in very short circumferences. The reason is this: Grommet Slings are made from one continuous length of strand or wire rope. This requires only one tuck-in point as compared with six tuck-in points needed to manufacture an endless sling.

Grommets made from strand are called Rope Grommets — and are used for high resistance to abrasion. Grommets made from wire rope are called Cable Grommets — and are used where extra flexibility is needed. Many fittings are adaptable for use with Grommet Slings.

#### Length Tolerance

Grommets are made to a length tolerance of plus or minus 6 sling body diameters or plus or minus 1% of circumferential sling length, whichever is greater.



Grommet Sling

Table 3-20. Rope Grommets

Size (in.)	Construction	Minimum Circum. (ft.)	Rated Capacity (Tons 2,000 lbs.) ①					
			Straight Pull	Choker Hitch	Basket Hitch — Horizontal			
					90°	60°	45°	30°
1/4	7 x 19	2	.85	.64	1.7	1.5	1.2	.80
3/8	7 x 19	3	1.9	1.4	3.8	3.3	2.7	1.9
1/2	7 x 19	4	3.3	2.5	6.7	5.8	4.7	3.4
5/8	7 x 19	5	5.2	3.9	10.0	8.6	7.1	5.0
3/4	7 x 19	6	7.4	5.6	15.0	13.0	11.0	7.5
7/8	7 x 19	7	10.0	7.5	20.0	17.0	14.0	10.0
1	7 x 19	8	13.0	9.7	26.0	23.0	18.0	13.0
1-1/8	7 x 19	9	16.0	12.0	32.0	28.0	23.0	16.0
1-1/4	7 x 37	10	19.0	15.0	39.0	34.0	27.0	19.0
1-3/8	7 x 37	11	23.0	18.0	47.0	40.0	33.0	23.0
1-1/2	7 x 37	12	28.0	21.0	55.0	48.0	39.0	28.0

① Rated loads are based on a diameter of curvature of 5 times the individual rope diameter at points of sling contact with load.

Table 3-21. Cable Grommets

Size (in.)	Construction	Minimum Circum. (ft.)	Rated Capacity (Tons 2,000 lbs.) ①					
			Straight Pull	Choker Hitch	Basket Hitch — Horizontal			
					90°	60°	45°	30°
3/8	7 x 6 x 7	3.0	1.3	.95	2.5	2.2	1.8	2.2
9/16	7 x 6 x 7	4.5	2.8	2.1	5.6	4.8	4.0	2.8
5/8	7 x 6 x 7	5.0	3.8	2.8	7.6	6.6	5.4	3.8
3/8	7 x 7 x 7	3.0	1.6	1.2	3.2	2.8	2.3	1.6
9/16	7 x 7 x 7	4.5	3.5	2.6	6.9	6.0	4.9	3.4
5/8	7 x 7 x 7	5.0	4.5	3.4	9.0	7.8	6.4	4.5
5/8	7 x 6 x 19	5.0	3.9	3.0	7.9	6.8	5.6	3.9
3/4	7 x 6 x 19	6.0	5.1	3.8	10.0	8.7	7.1	5.0
15/16	7 x 6 x 19	7.5	7.9	5.9	16.0	14.0	11.0	8.0
1-1/8	7 x 6 x 19	9.0	11.0	8.4	22.0	19.0	16.0	11.0
1-5/16	7 x 6 x 19	10.5	15.0	11.0	30.0	26.0	21.0	15.0
1-1/2	7 x 6 x 19	12.0	19.0	14.0	39.0	34.0	28.0	19.0
1-11/16	7 x 6 x 19	13.5	24.0	18.0	49.0	42.0	35.0	24.0
1-7/8	7 x 6 x 19	15.0	30.0	22.0	60.0	52.0	42.0	30.0
2-1/4	7 x 6 x 19	18.0	42.0	31.0	84.0	73.0	59.0	42.0
2-5/8	7 x 6 x 19	21.0	56.0	42.0	112.0	97.0	79.0	56.0

① Rated loads are based on a diameter of curvature of 5 times the individual rope diameter at points of sling contact with load.

### Uni-Ply (Cable-Laid)

#### All Types

Flexibility is the outstanding characteristic of Union Wire Rope Uni-Ply Slings. This extra flexibility is obtained through the use of special multi-wire ropes. The eye is formed with a Flemish eye splice and a pressed-on ferrule. Uni-Ply Slings range from 3/8-inch through 1-1/4 inches. They are available in all types U-1 through U-13. All Uni-Ply Slings are made from galvanized wire.

#### Length Tolerance

Uni-Ply Slings are made to a length tolerance of plus or minus 2 rope diameters or plus or minus 0.5% of sling length, whichever is greater. Slings which are used as a matched set are within 1 rope diameter of each other.

Table 3-22. Uni-Ply Slings

Rope Diameter (in.)	Construction	Eye Size (in.)		Recommended Minimum Length	Rated Capacity (Tons 2,000 lbs.) ①					
		W	L		Straight Pull	Choker Hitch	Basket Hitch — Horizontal			
							90°	60°	45°	30°
1/4	7 x 7 x 7	2	4	1'4"	.50	.38	1.0	.87	.71	.50
3/8	7 x 7 x 7	3	6	1'10"	1.1	.81	2.0	1.7	1.4	1.0
1/2	7 x 7 x 7	4	8	2'6"	1.8	1.4	3.7	3.2	2.6	1.8
5/8	7 x 7 x 7	5	10	3'2"	2.8	2.1	5.5	4.7	3.8	2.7
3/4	7 x 7 x 7	6	12	3'8"	3.8	2.9	7.6	6.6	5.3	3.8
5/8	7 x 7 x 19	5	10	3'2"	2.9	2.2	5.8	5.0	4.1	2.9
3/4	7 x 7 x 19	6	12	3'8"	4.1	3.0	8.1	7.0	5.7	4.0
7/8	7 x 7 x 19	7	14	4'4"	5.4	4.0	11.0	9.5	7.8	5.5
1	7 x 7 x 19	8	16	4'10"	6.9	5.1	14.0	12.0	9.9	7.0
1-1/8	7 x 7 x 19	9	18	5'6"	8.2	6.2	16.0	14.0	11.0	8.0
1-1/4	7 x 7 x 19	10	20	6'2"	9.9	7.4	20.0	17.0	14.0	10.0
3/4	7 x 6 x 19 IWRC	6	12	3'8"	3.8	2.8	7.6	6.6	5.3	3.8
7/8	7 x 6 x 19 IWRC	7	14	4'4"	5.0	3.8	10.0	8.6	7.0	5.0
1	7 x 6 x 19 IWRC	8	16	4'10"	6.4	4.8	13.0	11.0	9.1	6.5
1-1/8	7 x 6 x 19 IWRC	9	18	5'6"	7.7	5.8	15.0	13.0	10.0	7.5
1-1/4	7 x 6 x 19 IWRC	10	20	6'2"	9.2	6.9	18.0	15.0	12.0	9.0
1-3/8	7 x 6 x 19 IWRC	11	22	6'10"	11.0	8.2	22.0	19.0	15.0	11.0
1-1/2	7 x 6 x 19 IWRC	12	24	7'4"	13.0	9.6	26.0	22.0	18.0	13.0

① Rated loads are based on the diameter of curvature of 10 times the individual rope diameter at points of sling contact with load.



Uni-Ply

# WIRE ROPE

Amick Associates, Inc.

## Hand-Spliced Slings

version #1-18

### Hand-Spliced Slings

#### Length Tolerance

Hand-spliced slings are manufactured to a length tolerance of plus or minus 2 rope diameters, or plus or minus 0.5% of sling length, whichever is greater. Slings which will be used as matched sets will be within 1 rope diameter of each other.

Table 3-23. 6 x 19 and 6 x 37 Classification, XIP, IWRC

Rope Diameter (in.)	Construction	Eye Size (in.)		Rated Capacity (Tons 2,000 lbs.) <sup>①</sup>			Recommended Minimum Length
		W	L	Vertical	Choker Hitch	Vertical Basket Hitch	
1/4	6 x 19	3	6	0.54	0.42	1.1	1'10"
5/16	6 x 19	3	6	0.83	0.66	1.7	2'0"
3/8	6 x 19	3	6	1.2	0.94	2.4	2'2"
7/16	6 x 19	4	8	1.6	1.3	3.2	2'8"
1/2	6 x 19	4	8	2.0	1.6	4.0	2'10"
9/16	6 x 19	5	10	2.5	2.1	5.0	3'4"
5/8	6 x 19	5	10	3.1	2.6	6.2	3'6"
3/4	6 x 19	6	12	4.3	3.7	8.6	4'2"
7/8	6 x 19	7	14	5.7	5.0	11.0	5'2"
1	6 x 19	8	16	7.4	6.4	15.0	5'10"
1-1/8	6 x 19	9	18	9.3	8.1	19.0	6'8"
1-1/4	6 x 37	10	20	11.0	9.9	23.0	7'4"
1-3/8	6 x 37	11	22	14.0	12.0	27.0	8'0"
1-1/2	6 x 37	12	24	16.0	14.0	32.0	8'10"
1-5/8	6 x 37	13	26	19.0	16.0	38.0	9'6"
1-3/4	6 x 37	14	28	22.0	19.0	44.0	10'4"
2	6 x 37	16	32	28.0	25.0	56.0	11'8"

<sup>①</sup> Rated loads are based on a diameter of curvature of 10 times the individual rope diameter at points of sling contact with load.



Hand-Spliced Slings

### Hand-Braided Slings

#### 8 Part

All 8-part slings are round bodied. Type U-1 is a general purpose sling adaptable for basket and straight pull hitches. Type U-3 is recommended for pipe, bundles bars, castings, lumber – for any type of load which lends itself to a choker hitch. Type U-4 is a two-part bridle choker sling. Each part has a sliding hook and is braided into a pear or oblong shaped link. This type of sling eliminates load rotation and is well suited for handling pipe, bar stock, timber, tanks, castings and other hard-to-handle loads which run in longer lengths.

**Table 3-24. U-1**

Comp. Part Size (in.)	Eye Size (in.)		Recom- mended Minimum Length	Rated Capacity (Tons 2,000 lbs.) ①							Fittings ②	
	W	L		Straight Pull	Choker Hitch	Basket Hitch — Horizontal				Crescent Thimble	Slip-thru Thimble	
						90°	60°	45°	30°			
1/8	3	6	1'6"	.95	.71	1.9	1.6	1.3	.95	8C	W3	
3/16	4	8	1'10"	2.1	1.5	4.1	3.6	2.9	2.1	8C	W3	
1/4	5	10	2'6"	3.1	2.3	6.1	5.3	4.3	3.1	10C	W4	
5/16	6	12	2'10"	4.8	3.6	9.5	8.3	6.7	4.8	14C	W5	
3/8	7	14	3'2"	6.8	5.1	14.0	12.0	9.7	6.8	16C	W5	
7/16	8	16	3'10"	9.3	6.9	18.0	16.0	13.0	9.3	18C	W6	
1/2	9	18	4'4"	12.0	9.0	24.0	21.0	17.0	12.0	20C	W7	
9/16	10	20	4'8"	15.0	11.0	30.0	26.0	21.0	15.0	22C	W7	
5/8	11	22	5'2"	19.0	14.0	37.0	32.0	26.0	19.0	24C	W8	
3/4	12	24	6'2"	27.0	20.0	53.0	46.0	38.0	27.0	28C	W9	
7/8	14	28	7'0"	36.0	27.0	72.0	62.0	51.0	36.0	40C	W10	
1	16	32	8'2"	47.0	35.0	94.0	81.0	66.0	47.0	48C	W11	

① Rated loads are based on a diameter of curvature of 20 times the component part size at points of sling contact with load.  
 ② Fittings must be specified when ordering slings.

**Table 3-25. U-3**

Component Part Size (in.)	Eye Size (in.)		Recommended Minimum Length	Rated Capacity (Tons 2,000 lbs.) ①	Fittings ②		
	W	L			Choker Hitch	Sliding Hook No.	Choker Thimble No.
1/8	3	6	1'6"	.71	2	82	W3
3/16	4	8	2'	1.5	3	83	W3
1/4	5	10	2'6"	2.3	4	84	W4
5/16	6	12	3'	3.6	5	85	W5
3/8	7	14	3'6"	5.1	6	86	W5
7/16	8	16	4'	6.9	7	87	W6

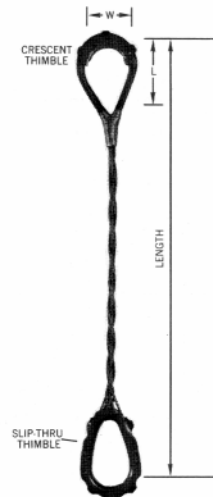
① Rated loads are based on a diameter of curvature of 20 times the component part size at points of sling contact with load.  
 ② Fittings must be specified when ordering slings.

**Table 3-26. U-4**

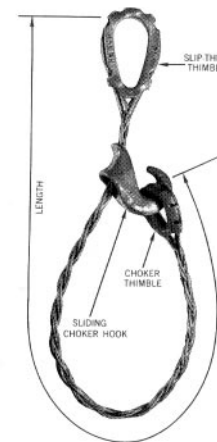
Comp. Part Size (in.)	Eye Size (in.)		Recom- mended Minimum Length	Rated Capacity (Tons 2,000 lbs.) — Horizontal ①				Fittings ②			
	W	L		90°	60°	45°	30°	Sliding Hook No.	Choker Thimble No.	Slip-thru Thimble	Link No.
1/8	3	6	1'6"	1.4	1.2	1.0	.71	2	82	W3	L-1
3/16	4	8	2'	3.1	2.7	2.2	1.5	3	83	W3	L-3
1/4	5	10	2'6"	4.6	4.0	3.2	2.3	4	84	W4	L-4
5/16	6	12	3'	7.1	6.2	5.1	3.6	5	85	W5	L-5
3/8	7	14	3'6"	10.0	8.9	7.2	5.1	6	86	W5	L-11
7/16	8	16	4'	14.0	12.0	9.8	6.9	7	87	W6	L-12

① Rated loads are based on a diameter of curvature of 20 times the component part size at points of sling contact with load.  
 ② Fittings must be specified when ordering slings.

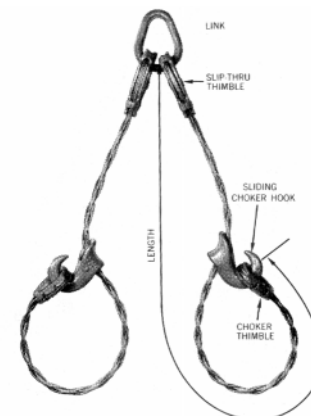
**Note:** When a solid fitting is used at both ends, the fitting on the pear or oblong link will be cut and welded. Various fittings may be adapted to the type of sling. If larger slings are requested, fittings may not be available.



**8 Part/U-1**



**8 Part/U-3**



**8 Part/U-4**

# WIRE ROPE

## Hand-Braided Slings

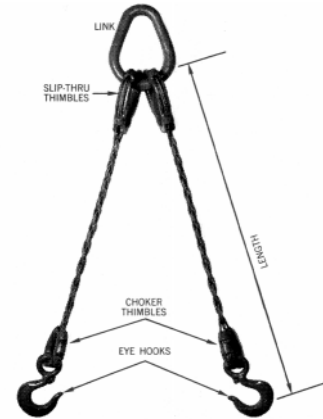
### 8 Part

Type U-6 is one of the most popular of the two-legged slings. Eyes are braided into a pear or oblong shaped link, with the other ends braided into eye hooks. Efficient for such applications as lifting machinery, castings, motors and aircraft assemblies. Type U-8 has extra stamina for heavy, bulky loads. Ideal for handling ship sections, planer beds, founder's molds, pressure vessel man-holes and similar loads. Type U-9 is a bridle sling with 3 legs. Gives sure balance in lifting such heavy things as dies, castings, and assemblies which must be lifted and placed carefully.

Table 3-27. U-6

Comp. Part Size (in.)	Recommended Minimum Length	Rated Capacity (Tons 2,000 lbs.) — Horizontal				Fittings ①			
		90°	60°	45°	30°	Link No.	Eye Hook No.	Slip-thru Thimble	Choker Thimble No.
1/8	1'6"	1.9	1.6	1.3	.95	L-1	24	W3	82
3/16	1'10"	4.1	3.6	2.9	2.1	L-3	26	W3	83
1/4	2'6"	6.1	5.3	4.3	3.1	L-5	28	W4	84
5/16	2'10"	9.5	8.3	6.7	4.8	L-10	29	W5	85
3/8	3'2"	14.0	12.0	9.7	6.8	L-12	31	W5	86
7/16	3'8"	18.0	16.0	13.0	9.3	L-13	32	W6	87

① Fittings must be specified when ordering slings.

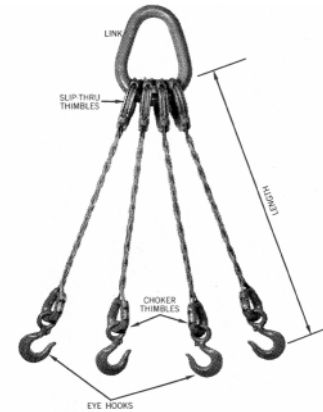


8 Part/U-6

Table 3-28. U-8

Comp. Part Size (in.)	Recommended Minimum Length	Rated Capacity (Tons 2,000 lbs.) — Horizontal				Fittings ①			
		90°	60°	45°	30°	Link No.	Eye Hook No.	Slip-thru Thimble	Choker Thimble No.
1/8	1'6"	3.8	3.3	2.7	1.9	L-5	24	W3	82
3/16	1'10"	8.3	7.2	5.8	4.1	L-5	26	W3	83
1/4	2'6"	12.0	11.0	8.7	6.1	L-12	28	W4	84
5/16	2'10"	19.0	16.0	13.0	9.5	L-17	29	W5	85
3/8	3'2"	27.0	24.0	19.0	14.0	L-17	31	W5	86
7/16	3'8"	37.0	32.0	26.0	18.0	L-19	32	W6	87

① Fittings must be specified when ordering slings.



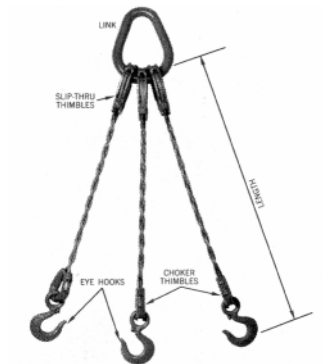
8 Part/U-8

Table 3-29. U-9

Comp. Part Size (in.)	Recommended Minimum Length	Rated Capacity (Tons 2,000 lbs.) — Horizontal				Fittings ①			
		90°	60°	45°	30°	Link No.	Eye Hook No.	Slip-thru Thimble	Choker Thimble No.
1/8	1'6"	2.8	2.5	2.0	1.4	L-3	24	W3	82
3/16	1'10"	6.2	5.4	4.4	3.1	L-5	26	W3	83
1/4	2'6"	9.2	8.0	6.5	4.6	L-11	28	W4	84
5/16	2'10"	14.0	12.0	10.0	7.1	L-12	29	W5	85
3/8	3'2"	20.0	18.0	14.0	10.0	L-13	31	W5	86
7/16	3'8"	28.0	24.0	20.0	14.0	L-15	32	W6	87

① Fittings must be specified when ordering slings.

**Note:** When a solid fitting is used in both ends, the fitting on the pear or oblong link will be cut and welded. Various fittings may be adapted to the type sling. If larger slings than listed are requested, fittings may not be available.



8 Part/U-9

### 6 Part

All 6-part slings are flat bodied for unequalled gripping and load hugging characteristics. Type U-1 is a general purpose sling adaptable for basket and straight pull hitches. Type U-3 is a choker type sling that is quickly hitched and holds tight. Type U-4 is a two-part bridle-choker sling that eliminates load rotation. Suitable for handling pipe, bar stock, timber, tanks castings and other loads which run in longer lengths.

Table 3-30. U-1

Component Part Size (in.)	Eye Size (in.)		Recommended Minimum Length	Rated Capacity (Tons 2,000 lbs.) — Horizontal ①						Fittings ②	
	W	L		Straight Pull	Choker Hitch	90°	60°	45°	30°	Crescent Thimble	Slip-thru Thimble
1/8	3	6	1'4"	.71	.53	1.4	1.2	1.0	.71	6C	W2
3/16	4	8	1'10"	1.5	1.2	3.1	2.7	2.2	1.5	8C	W3
1/4	5	10	2'2"	2.3	1.7	4.6	4.0	3.2	2.3	9C	W3
5/16	6	12	2'10"	3.6	2.7	7.1	6.2	5.0	3.6	10C	W4
3/8	7	14	3'2"	5.1	3.8	10.0	8.9	7.2	5.1	14C	W5
7/16	8	16	3'8"	6.9	5.2	14.0	12.0	9.8	6.9	16C	W5
1/2	9	18	4'2"	9.0	6.7	18.0	15.0	13.0	9.0	18C	W6
9/16	10	20	4'6"	11.0	8.5	23.0	20.0	16.0	11.0	18C	W6
5/8	11	22	4'10"	14.0	10.0	28.0	24.0	20.0	14.0	20C	W6
3/4	12	24	5'10"	20.0	15.0	40.0	35.0	28.0	20.0	24C	W8
7/8	14	28	6'10"	27.0	20.0	54.0	47.0	38.0	27.0	32C	W9
1	16	32	7'8"	35.0	26.0	70.0	61.0	50.0	35.0	40C	W10

- ① Rated loads are based on a diameter of curvature of 20 times the component part size at points of sling contact with load.
- ② Fittings must be specified when ordering slings.

Table 3-31. U-3

Component Part Size (in.)	Eye Size (in.)		Recommended Minimum Length	Rated Capacity (Tons 2,000 lbs.) ①			Fittings ②		
	W	L		Choker Hitch	Sliding Hook No.	Choker Thimble No.	Slip-thru Thimble		
1/8	3	6	1'6"	.53	2	82	W2		
3/16	4	8	2'	1.2	3	83	W3		
1/4	5	10	2'6"	1.7	4	83	W3		
5/16	6	12	3'	2.7	5	84	W4		
3/8	7	14	3'6"	3.8	6	85	W5		
7/16	8	16	4'	5.2	7	86	W5		
1/2	9	18	4'6"	6.7	8	87	W6		

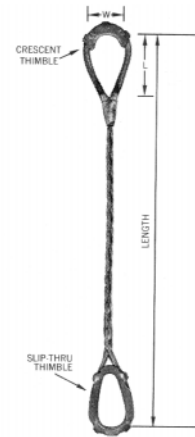
- ① Rated loads are based on a diameter of curvature of 20 times the component part size at points of sling contact with load.
- ② Fittings must be specified when ordering slings.

Table 3-32. U-4

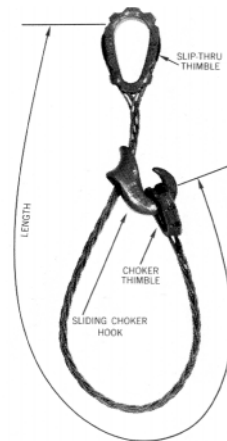
Comp. Part Size (in.)	Eye Size (in.)		Recommended Minimum Length	Rated Capacity (Tons 2,000 Lbs.) — Horizontal ①				Fittings ②			
	W	L		90°	60°	45°	30°	Sliding Hook No.	Choker Thimble No.	Slip-thru Thimble	Link No.
1/8	3	6	1'6"	1.1	.93	.77	.53	2	82	W2	L-0
3/16	4	8	2'	2.3	2.0	1.6	1.2	3	83	W3	L-2
1/4	5	10	2'6"	3.4	3.0	2.4	1.7	4	83	W3	L-3
5/16	6	12	3'	5.4	4.6	3.8	2.7	5	84	W4	L-4
3/8	7	14	3'6"	7.7	6.6	5.4	3.8	6	85	W5	L-5
7/16	8	16	4'	10.0	9.0	7.4	5.2	7	86	W5	L-11
1/2	9	18	4'6"	13.0	12.0	9.5	6.7	8	87	W6	L-12

- ① Rated loads are based on a diameter of curvature of 20 times the component part size at points of sling contact with load.
- ② Fittings must be specified when ordering slings.

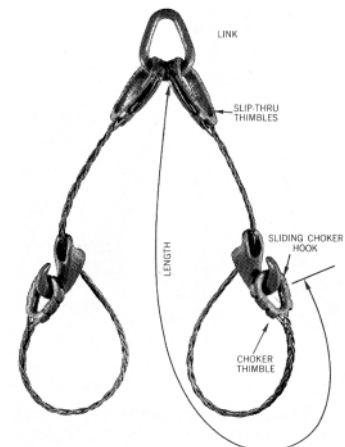
**Note:** When a solid fitting is used at both ends, the fitting on the pear or oblong link will be cut and welded. Various fittings may be adapted to the type sling. If larger slings than listed are requested, fittings may not be available.



6 Part/U-1



6 Part/U-3



6 Part/U-4

# WIRE ROPE

Amick Associates, Inc.

## Hand-Braided Slings

version #1-18

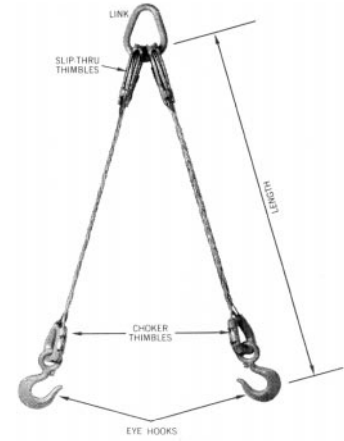
### 6 Part

Type U-6 is commonly used for lifting machinery, castings, motors, aircraft assemblies and rolls of paper. It is one of the most popular of the two-legged slings. Type U-8 has extra stamina for heavy, bulky loads. Use to lift ship sections, planer beds, founder's molds, pressure vessel manholes and other heavy loads. Type U-9 is a sure balance bridle sling with three legs. It is used for lifting dies, castings, assemblies and other heavy loads which must be lifted and placed carefully. Eyes are braided into pear or oblong shaped links and eye hooks.

Table 3-33. U-6

Comp. Part Size (in.)	Recommended Minimum Length	Rated Capacity (Tons 2,000 lbs.) — Horizontal				Fittings ①			
		90°	60°	45°	30°	Link No.	Eye Hook No.	Slip-thru Thimble	Choker Thimble No.
1/8	1'6"	1.4	1.2	1.0	.71	L-0	24	W2	82
3/16	1'10"	3.1	2.7	2.2	1.5	L-3	26	W3	83
1/4	2'2"	4.6	4.0	3.2	2.3	L-4	26	W3	83
5/16	2'8"	7.1	6.2	5.0	3.6	L-5	28	W4	84
3/8	3'	10.0	8.9	7.2	5.1	L-11	29	W5	85
7/16	3'6"	14.0	12.0	9.8	6.9	L-12	31	W5	86
1/2	4'0"	18.0	15.0	13.0	9.0	L-13	32	W6	87

① Fittings must be specified when ordering slings.

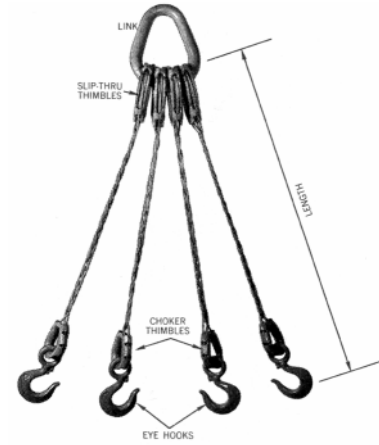


6 Part/U-6

Table 3-34. U-8

Comp. Part Size (in.)	Recommended Minimum Length	Rated Capacity (Tons 2,000 lbs.) — Horizontal				Fittings ①			
		90°	60°	45°	30°	Link No.	Eye Hook No.	Slip-thru Thimble	Choker Thimble No.
1/8	1'6"	2.8	2.5	2.0	1.4	L-4	24	W2	82
3/16	1'10"	6.2	5.4	4.4	3.1	L-5	26	W3	83
1/4	2'2"	9.2	8.0	6.5	4.6	L-11	26	W3	83
5/16	2'8"	14.0	12.0	10.0	7.1	L-12	28	W4	84
3/8	3'	20.0	18.0	14.0	10.0	L-17	29	W5	85
7/16	3'6"	28.0	24.0	20.0	14.0	L-17	31	W5	86
1/2	4'0"	36.0	31.0	25.0	18.0	L-19	32	W6	87

① Fittings must be specified when ordering slings.



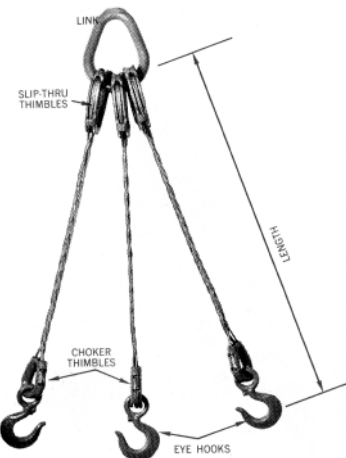
6 Part/U-8

Table 3-35. U-9

Comp. Part Size (in.)	Recommended Minimum Length	Rated Capacity (Tons 2,000 lbs.) — Horizontal				Fittings ①			
		90°	60°	45°	30°	Link No.	Eye Hook No.	Slip-thru Thimble	Choker Thimble No.
1/8	1'6"	2.1	1.8	1.5	1.1	L-2	24	W2	82
3/16	1'10"	4.7	4.0	3.3	2.4	L-4	26	W3	83
1/4	2'2"	6.9	6.0	4.9	3.4	L-5	26	W3	83
5/16	2'8"	11.0	9.3	7.6	5.4	L-11	28	W4	84
3/8	3'	15.0	13.0	11.0	7.6	L-12	29	W5	85
7/16	3'6"	21.0	18.0	15.0	10.0	L-13	31	W5	86
1/2	4'0"	27.0	23.0	19.0	13.0	L-15	32	W6	87

① Fittings must be specified when ordering slings.

**Note:** When a solid fitting is used at both ends, the fitting on the pear or oblong link will be cut and welded. Various fittings may be adapted to the type sling. If larger slings than listed are requested, fittings may not be available.

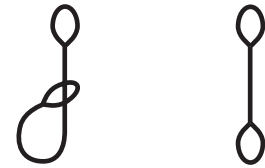


6 Part/U-9

### 3 Part Body — Single Leg Wire Rope Slings

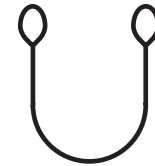
Table 3-36. 3 Part

Rope Diameter	Sling Diameter	Eye Size (in.)		Rated Capacity (Tons 2,000 lbs.)					
		W	L	Straight Pull	Choker Hitch	Basket Hitch — Horizontal			
						90°	60°	45°	30°
1/8	1/4	3	6	.57	.5	1.1	1.1	.99	.81
3/16	3/8	3	6	.95	.83	1.9	1.8	1.6	1.3
1/4	1/2	4	8	1.7	1.5	3.4	3.3	2.9	2.4
5/16	5/8	4	8	2.6	2.3	5.2	5.0	4.5	3.7
3/8	3/4	5	10	3.7	3.2	7.4	7.1	6.4	5.2
7/16	7/8	6	12	5.1	4.5	10.0	9.9	8.8	7.2
1/2	1	6	12	6.6	5.8	13.0	13.0	11.0	9.3
9/16	1-1/8	7-1/2	15	8.0	6.0	16.0	15.4	13.9	11.3
5/8	1-1/4	9	18	9.9	7.4	19.8	19.1	17.1	14.0
3/4	1-1/2	10	20	14.0	10.5	28.0	27.0	24.0	20.0
7/8	1-3/4	12	24	19.0	14.3	38.0	36.0	33.0	27.0
1	2	15	30	24.8	18.6	49.6	48.0	43.0	35.0
1-1/8	2-1/4	17	34	31.2	23.4	62.4	60.0	54.0	44.0
1-1/4	2-1/2	20	40	38.4	28.8	76.8	74.0	66.5	54.0
1-3/8	2-3/4	22	44	46.0	34.5	92.0	89.0	80.0	65.0
1-1/2	3	25	50	55.0	41.2	110.0	106.0	95.0	78.0
1-3/4	3-1/2	27	54	73.0	54.8	146.0	141.0	126.5	103.0
2	4	30	60	95.0	71.2	190.0	184.0	165.0	134.0
2-1/4	4-1/2	32	64	118.0	88.5	236.0	228.0	204.0	167.0
2-1/2	5	35	70	145.0	109.0	290.0	280.0	251.0	205.0

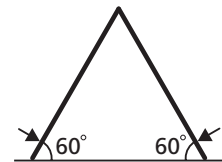


Choker Hitch

Vertical Hitch



90° Basket Hitch

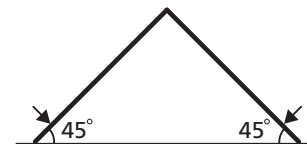


60° Basket Hitch

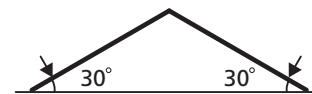
### 7 Part Body — IWRC EIP

Table 3-37. 7 Part

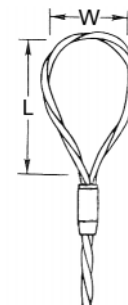
Rope Diameter	Sling Diameter	Eye Size (in.)		Rated Capacity (Tons 2,000 lbs.)					
		W	L	Straight Pull	Choker Hitch	Basket Hitch — Horizontal			
						90°	60°	45°	30°
1/8	13/32	3	6	1.1	.96	2.2	2.1	1.9	1.6
3/16	21/32	4	8	1.9	1.7	3.8	3.7	3.3	2.7
1/4	27/32	5	10	3.5	3.1	7.0	6.7	6.1	5.0
5/16	1-1/32	6	12	5.2	4.6	10.0	9.7	8.7	7.1
3/8	1-7/32	7-1/2	15	7.4	6.5	15.0	14.5	13.0	10.6
7/16	1-13/32	9	18	10.0	8.8	20.0	19.3	17.3	14.1
1/2	1-19/32	10	20	13.0	11.0	26.0	25.1	22.5	18.4
9/16	1-25/32	12	24	16.0	14.0	32.0	30.9	27.7	22.6
5/8	1-31/32	12	24	20.0	18.0	40.0	38.6	34.6	28.3
3/4	2-11/32	15	30	29.0	25.0	58.0	56.0	50.2	41.0
7/8	2-3/4	17	34	39.0	34.0	78.0	75.0	67.0	55.0
1	3	20	40	51.0	45.0	102.0	98.0	88.0	72.0



45° Basket Hitch



30° Basket Hitch



Eye Dimensions  
Mechanical Splice

# WIRE ROPE

*Amick Associates, Inc.*

## Wire Rope Inspections and Repairs

version #1-18

### Wire Rope Inspections and Repairs

In our never-ending effort to keep our customer's overhead lifting products safe and reliable, Amick Associates offers wire rope inspections. Customers can schedule wire rope inspections annually, semi-annually, or quarterly with minimal interruption of plant work schedules.

All wire ropes will wear out eventually and gradually lose work capability throughout their service life. That's why periodic inspections are critical. Applicable industry standards such as ASME B30.2 for overhead and gantry cranes or federal regulations such as OSHA refer to specific inspection criteria for varied applications.

#### Three Purposes for Inspection:

- Reveals the rope's condition and indicates a possible need for replacement.
- Indicates if you are using the most suitable type of rope for the given application.
- Makes possible the discovery and correction of faults in equipment or operation that can cause costly accelerated rope wear.

As with all of our inspections, the Amick inspector will review the inspection with a customer representative before leaving the premises to discuss corrective action or procedures.

#### About the Repairs:

Amick can revise and recertify your fittings on your wire rope bridle slings. High strength wire rope used to make your sling lift stronger and safer. All repaired slings tagged, tested and certified as per OSHA and ANSI regulations.

3

# FITTINGS & BLOCKS

## Wire Rope Clips

Crosby® Clips

## Forged Shackles

Anchor, Chain & Bolt Type Shackles

## Hooks & Latches

Hoist, Shank & Swivel Hooks

Hook Connectors

Crosby® Latch Kit

## Turnbuckles

## Wire Rope Thimbles

## End Fittings, Swage & Spelter Sockets

National Swage Buttons

S-421T Wedge Sockets

Open & Closed Swage Sockets

Open & Closed Spelter Sockets

## Eye Nuts, Pad Eyes & Hoist Rings

## Forged Eye Bolts

Regular Nut, Shoulder Nut, Screw Eye Bolts

## Load Binders

L-140 Binders

## Blocks

Ordering Information

McKissick® Utility Crane Blocks — 380 Series

Construction & Crane Blocks —

Important Considerations in Block Requirements

Snatch Blocks

## Sheaves

McKissick® Sheaves

# FITTINGS & BLOCKS

Amick Associates, Inc.

## Wire Rope Clips

version #2-04

the **Crosby** group  
inc.

Made in the U.S.A. 

## Wire Rope Clips

### Crosby® Clips

- Each base has a Product Identification Code (PIC) for material traceability, the name CROSBY or "CG," and a size forged into it.
- Sizes 1/8" through 2-1/2" have forged bases.
- Entire clip — galvanized to resist corrosive and rusting action.
- Only genuine Crosby clips have a Red-U-Bolt® for instant recognition.
- All clips are individually bagged or tagged with proper application instructions and warning information.
- Clip sizes up through 1-1/2" have rolled threads.

**Note:** Crosby clips, all sizes 1/4" and larger, meet the performance requirements of Federal Specification FF-C-450 TYPE 1 CLASS 1, except for those provisions required of the contractor.



G-450

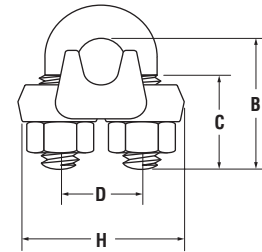
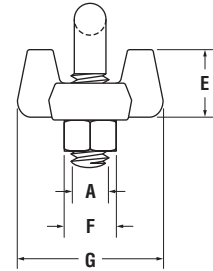


Table 4-1. Crosby Clips

Rope Size (in.)	G-450 Stock No. Galvanized	Standard Package Quantity	Weight per 100 (lbs.)	Dimensions (in.)							
				A	B	C	D	E	F	G	H
1/8 ①	1010015	100	6	.22	.72	.44	.47	.41	.38	.81	.94
3/16 ①	1010033	100	10	.25	.97	.56	.59	.50	.44	.94	1.16
1/4	1010051	100	19	.31	1.03	.50	.75	.66	.56	1.19	1.44
5/16	1010079	100	28	.38	1.38	.75	.88	.72	.69	1.31	1.69
3/8	1010097	100	48	.44	1.50	.75	1.00	.91	.75	1.63	1.94
7/16	1010113	50	78	.50	1.88	1.00	1.19	1.03	.88	1.81	2.28
1/2	1010131	50	80	.50	1.88	1.00	1.19	1.13	.88	1.91	2.28
9/16	1010159	50	109	.56	2.25	1.25	1.31	1.22	.94	2.06	2.50
5/8	1010177	50	110	.56	2.38	1.25	1.31	1.34	.94	2.06	2.50
3/4	1010195	25	142	.62	2.75	1.44	1.50	1.41	1.06	2.25	2.84
7/8	1010211	25	212	.75	3.12	1.62	1.75	1.59	1.25	2.44	3.16
1	1010239	10	252	.75	3.50	1.81	1.88	1.78	1.25	2.63	3.47
1-1/8	1010257	10	283	.75	3.88	2.00	2.00	1.91	1.25	2.81	3.59
1-1/4	1010275	10	438	.88	4.25	2.13	2.31	2.19	1.44	3.13	4.13
1-3/8	1010293	10	442	.88	4.63	2.31	2.38	2.31	1.44	3.13	4.19
1-1/2	1010319	10	544	.88	4.94	2.38	2.59	2.44	1.44	3.41	4.44
1-5/8	1010337	Bulk	704	1.00	5.31	2.62	2.75	2.66	1.63	3.63	4.75
1-3/4	1010355	Bulk	934	1.13	5.75	2.75	3.06	2.94	1.81	3.81	5.28
2	1010373	Bulk	1,300	1.25	6.44	3.00	3.38	3.28	2.00	4.44	5.88
2-1/4	1010391	Bulk	1,600	1.25	7.13	3.19	3.88	3.19	2.00	4.50	6.38
2-1/2	1010417	Bulk	1,900	1.25	7.69	3.44	4.13	3.69	2.00	4.05	6.63
2-3/4 ②	1010435	Bulk	2,300	1.25	8.31	3.56	4.38	4.88	2.00	5.00	6.88
3	1010453	Bulk	3,100	1.50	9.19	3.88	4.75	4.69	2.38	5.88	7.63
3-1/2 ②	1010426	Bulk	4,000	1.50	10.75	4.50	5.50	6.00	2.38	6.19	8.38

① Electro-plated U-Bolt and Nuts.

② 2-3/4" and 3-1/2" base is made of cast steel.



Made in the U.S.A.

### Forged Shackles

- Working Load Limit permanently shown on every shackle.
- Forged, quenched and tempered, with alloy pins.
- Capacities 1/3 through 150 tons.
- Look for the red color...mark of genuine Crosby-Laughlin quality.
- Shackles can be furnished proof tested with certificates to designated standards (i.e., ABS, Lloyds, etc.). Charges for proof testing and certification available upon request.
- Hot dip galvanized or self colored.



**G-209 S-209**  
**Screw Pin Anchor Shackle**

Note: Screw pin anchor shackles meet Federal Specification RR-C-271b Type IV Class 1.



**G-213 S-213**  
**Round Pin Anchor Shackle**

Note: Round pin anchor shackles meet Federal Specification RR-C-271b Type IV Class 4.

4

**Table 4-2. Anchor Shackles**

Working Load Limit (tons)	Nominal Shackle Size (in.)	Dimensions (in.)								Weight (lbs.)	
		Inside Length	Inside Width		Diameter		Tolerance Plus or Minus		213	209	
			at Pin	at Bow	Pin	Outside of Eye	Length	Width			
1/3 ①	3/16	7/8	3/8	11/16	1/4	9/16	1/16	1/16	—	.05	
1/2	1/4	1-1/8	1/2	25/32	5/16	11/16	1/16	1/16	.13	.12	
3/4	5/16	1-7/32	17/32	27/32	3/8	13/16	1/16	1/16	.17	.19	
1	3/8	1-7/16	21/32	1-1/32	7/16	31/32	1/8	1/16	.25	.31	
1-1/2	7/16	1-11/16	23/32	1-5/32	1/2	1-1/16	1/8	1/16	.38	.38	
2	1/2	1-7/8	13/16	1-5/16	5/8	1-3/16	1/8	1/16	.70	.63	
3-1/4	5/8	2-3/8	1-1/16	1-11/16	3/4	1-9/16	1/8	1/16	1.50	1.38	
4-3/4	3/4	2-13/16	1-1/4	2	7/8	1-7/8	1/4	1/16	2.32	2.25	
6-1/2	7/8	3-5/16	1-7/16	2-9/32	1	2-1/8	1/4	1/16	3.40	3.38	
8-1/2	1	3-3/4	1-11/16	2-11/16	1-1/8	2-3/8	1/4	1/16	5.00	5.32	
9-1/2	1-1/8	4-1/4	1-13/16	2-29/32	1-1/4	2-5/8	1/4	1/16	6.97	6.81	
12	1-1/4	4-11/16	2-1/32	3-1/4	1-3/8	3	1/4	1/16	9.75	9.50	
13-1/2	1-3/8	5-3/16	2-1/4	3-1/2	1-1/2	3-5/16	1/4	1/8	13.25	13.25	
17	1-1/2	5-3/4	2-3/8	3-7/8	1-5/8	3-5/8	1/4	1/8	17.25	17.70	
25	1-3/4	7	2-7/8	5	2	4-5/16	3/4	1/8	29.46	30.38	
35	2	7-3/4	3-1/4	5-3/4	2-1/4	5	3/4	1/8	45.75	45.00	
55 ①	2-1/2	10-1/2	4-1/8	7-1/4	2-3/4	6	3/4	1/4	—	85.75	

① Furnished in Screw Pin only.

# FITTINGS & BLOCKS

Amick Associates, Inc.

## Forged Shackles

version #2-04

the **Crosby** group  
inc.

Made in the U.S.A. 



**G-210 S-210**  
**Screw Pin Chain Shackle**

**Note:** Screw pin chain shackles meet Federal Specification RR-C-271b Type IV Class 2.



**G-215 S-215**  
**Round Pin Chain Shackle**

**Note:** Round pin chain shackles meet Federal Specification RR-C-271b Type IV Class 5.



**G-2130 S-2130**  
**Bolt Type Anchor Shackle With  
Thin Head Bolt — Nut With Cotter Pin**

**Note:** Bolt type anchor shackles with thin head bolt — nut with cotter pin: Meets Federal Specification RR-C-271b Type IV Class 6.



**G-2150 S-2150**  
**Bolt Type Chain Shackle With  
Thin Hex Head Bolt — Nut With Cotter Pin**

**Table 4-3. Chain Shackles — Round Pin & Screw Pin**

Working Load Limit (tons)	Nominal Shackle Size (in.)	Dimensions (in.)						Weight (lbs.)	
		Inside Length	Inside Width	Diameter		Tolerance Plus or Minus		210	215
				Pin	Outside of Eye	Length	Width		
1/2	1/4	7/8	15/32	5/16	11/16	1/16	1/16	.11	.10
3/4	5/16	1-1/32	17/32	3/8	13/16	1/16	1/16	.17	.18
1	3/8	1-1/4	21/32	7/16	31/32	1/8	1/16	.24	.25
1-1/2	7/16	1-7/16	23/32	1/2	1-1/16	1/8	1/16	.40	.38
2	1/2	1-5/8	13/16	5/8	1-3/16	1/8	1/16	.59	.50
3-1/4	5/8	2	1-1/16	3/4	1-9/16	1/8	1/16	1.21	1.21
4-3/4	3/4	2-3/8	1-1/4	7/8	1-7/8	1/4	1/16	2.25	2.00
6-1/2	7/8	2-13/16	1-7/16	1	2-1/8	1/4	1/16	3.16	3.28
8-1/2	1	3-3/16	1-11/16	1-1/8	2-3/8	1/4	1/16	4.75	4.75
9-1/2	1-1/8	3-9/16	1-13/16	1-1/4	2-5/8	1/4	1/16	6.75	6.30
12	1-1/4	3-15/16	2-1/32	1-3/8	3	1/4	1/8	9.06	9.00
13-1/2	1-3/8	4-3/8	2-1/4	1-1/2	3-5/16	1/4	1/8	11.63	12.00
17	1-1/2	4-13/16	2-3/8	1-5/8	3-5/8	1/4	1/8	15.95	16.15
25	1-3/4	5-3/4	2-7/8	2	4-1/8	3/4	1/8	26.75	29.96
35	2	6-3/4	3-1/4	2-1/4	5	3/4	1/8	42.31	43.25
55 ①	2-1/2	8	4-1/8	2-3/4	6	3/4	1/4	71.75	—

① Furnished in Screw Pin only.

**Table 4-4. Bolt Type Shackles — Anchor & Chain**

Working Load Limit (tons)	Nominal Shackle Size (in.)	Dimensions (in.)								Weight (lbs.)	
		Inside Length		Inside Width at Pin	Diameter		Tolerance Plus or Minus		2130	2150	
		2130	2150		Pin	Outside of Eye	Length	Width			
2	1/2	1-7/8	1-5/8	13/16	5/8	1-3/16	1/8	1/16	.79	.75	
3-1/4	5/8	2-3/8	2	1-1/16	3/4	1-9/16	1/8	1/16	1.68	1.47	
4-3/4	3/4	2-13/16	2-3/8	1-1/4	7/8	1-7/8	1/4	1/16	2.72	2.52	
6-1/2	7/8	3-5/16	2-13/16	1-7/16	1	2-1/8	1/4	1/16	3.95	3.85	
8-1/2	1	3-3/4	3-3/16	1-11/16	1-1/8	2-3/8	1/4	1/16	6.12	5.55	
9-1/2	1-1/8	4-1/4	3-9/16	1-13/16	1-1/4	2-5/8	1/4	1/16	8.27	7.60	
12	1-1/4	4-11/16	3-15/16	2-1/32	1-3/8	3	1/4	1/16	11.71	10.81	
13-1/2	1-3/8	5-3/16	4-3/8	2-1/4	1-1/2	3-5/16	1/4	1/8	15.38	13.75	
17	1-1/2	5-3/4	4-13/16	2-3/8	1-5/8	3-5/8	1/4	1/8	20.80	18.50	
25	1-3/4	7	5-3/4	2-7/8	2	4-1/8	3/4	1/8	33.91	31.40	
35	2	7-3/4	6-3/4	3-1/4	2-1/4	5	3/4	1/8	52.25	46.75	
55	2-1/2	10-1/2	8	4-1/8	2-3/4	6	3/4	1/4	98.25	85.00	
85 ①	3	13	8-1/2	5	3-1/4	6-1/2	1/4	1/4	154.00	124.25	
120 ①	3-1/2	14-5/8	—	5-1/4	3-3/4	8	1/4	1/4	265.00	—	
150 ①	4	14-1/2	—	5-1/2	4-1/4	9	1/4	1/4	338.00	—	

① Individually proof tested.

**Note:** Maximum Proof Load is 2.2 x Working Load Limit or as designated. Minimum Ultimate Load is 6 x Working Load Limit.

## Hooks and Latches

### Hoist Hooks

Hoist hooks incorporate markings forged into the product which address two (2) QUIC-CHECK® features:

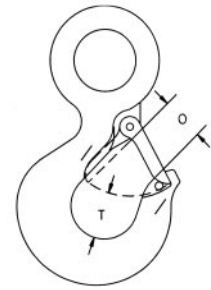
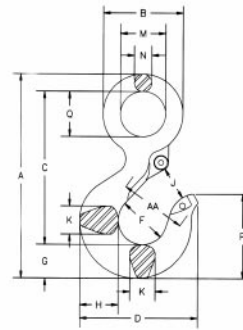
- 1. Deformation Indicators** — Two strategically placed marks, one just below the shank or eye and the other on the hook tip, which allows for QUIC-CHECK measurement to determine if the throat opening has changed, thus indicating abuse or overload.

**Note:** To check use measuring device (i.e., tape measure) to measure the distance between the marks. The marks should align to either an inch or half-inch increment on the measuring device. If the measurement does not meet this criteria, the hook should be inspected further for possible damage.

- 2. Angle Indicators** — Indicates the maximum included angle which is allowed between two (2) sling legs in the hooks. These indicators also provide the opportunity to approximate other included angles between two sling legs.



S-320N



S-320

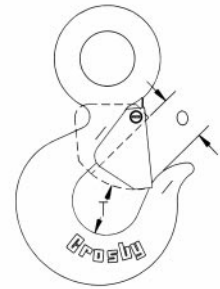
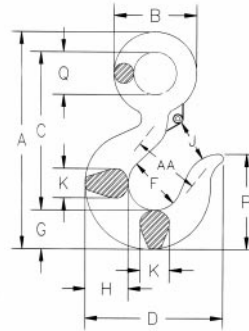


Table 4-5. Hoist Hooks

Working Load Limit <sup>①</sup> (tons)		Hook Identification Code		Dimensions (in.)													
Carbon	Alloy	S-320C Carbon	S-320A Alloy	A	B	C	D	F	G	H	J	K	M	O	P	Q	T
3/4 <sup>②</sup>	1 <sup>②</sup>	DC	DA	4.42	1.47	3.34	2.86	1.25	.73	.81	.93	.63	.63	.89	2.00	.75	.87
1 <sup>②</sup>	1-1/2 <sup>②</sup>	FC	FA	5.05	1.75	3.80	3.15	1.38	.84	.94	.97	.71	.71	.91	2.24	.91	.98
1-1/2 <sup>②</sup>	2 <sup>②</sup>	GC	GA	5.74	2.13	4.24	3.55	1.50	1.00	1.16	1.06	.88	.88	1.00	2.45	1.13	1.03
2 <sup>②</sup>	3 <sup>②</sup>	HC	HA	6.53	2.41	4.82	3.97	1.63	1.13	1.32	1.19	.94	.94	1.09	2.82	1.25	1.16
3 <sup>②</sup>	5 <sup>②</sup>	IC	IA	8.07	3.00	5.91	4.87	2.00	1.44	1.63	1.50	1.31	1.31	1.36	3.51	1.56	1.53
5 <sup>②</sup>	7 <sup>②</sup>	JC	JA	10.19	3.81	7.47	6.27	2.50	1.81	2.06	1.78	1.66	1.66	1.61	4.52	2.00	1.96
7 <sup>②</sup>	11 <sup>②</sup>	KC	KA	12.52	4.66	9.16	7.50	3.00	2.25	2.63	2.41	1.88	1.63	2.08	5.32	2.44	2.47
10 <sup>②</sup>	15 <sup>②</sup>	LC	LA	14.05	5.38	10.19	8.37	3.25	2.59	2.94	2.62	2.19	1.94	2.27	6.00	2.84	2.62
15 <sup>②</sup>	22 <sup>②</sup>	NC	NA	17.38	6.63	12.82	10.34	4.25	3.00	3.50	3.41	2.69	2.38	3.02	6.90	3.50	2.83
20 <sup>②</sup>	30 <sup>②</sup>	OC	OA	19.47	7.00	14.06	13.62	5.00	3.62	4.62	4.00	3.00	—	3.25	8.78	3.50	3.44
25 <sup>②</sup>	37 <sup>②</sup>	PC	PA	24.81	8.50	18.19	14.06	5.38	4.56	5.00	4.25	3.62	—	3.00	11.38	4.50	3.88
30 <sup>②</sup>	45 <sup>②</sup>	SC	SA	27.44	9.31	20.122	15.44	6.00	5.06	5.50	4.75	3.72	—	3.38	12.63	4.94	4.75
40 <sup>②</sup>	60 <sup>②</sup>	TC	TA	32.31	10.75	23.7	18.50	7.00	6.00	6.50	5.75	4.44	—	4.12	14.81	5.69	5.69

<sup>①</sup> Eye Hooks (3/4 TC – 22 TA), Proof Load is 2.0 x Working Load Limit. Eye Hooks (20 TC – 60 TA), Proof Load is 2 x Working Load Limit. All carbon hooks — average straightening load (ultimate load) is 5 x Working Load Limit. Alloy eye hooks 1 ton through 22 tons — average straightening load (ultimate load) is 5 x Working Load Limit. Alloy eye hooks 30 tons through 60 tons — average straightening load (ultimate load) is 4 x Working Load Limit. All alloy shank hooks — average straightening load (ultimate load) is 4 x Working Load Limit. All bronze hooks — average straightening load (ultimate load) is 4 x Working Load Limit.

<sup>②</sup> New 320N style hook.

<sup>③</sup> S-320 style hook.

# FITTINGS & BLOCKS

Amick Associates, Inc.

## Hooks and Latches

version #2-04

the **Crosby** group  
inc.

Made in the U.S.A.

### Shank Hooks

- The most complete line of shank hoist hooks.
- Available 3/4 to 300 tons.
- All 319N style hooks are metric rated.
- Available in carbon steel, alloy steel, and bronze.
- Quenched and tempered.
- Proper design, careful forging, and precision controlled quenched and tempering give maximum strength without excessive weight and bulk.
- Every Crosby Shank Hook has a pre-drilled cam which can be equipped with a latch.
- Even years after purchase of the original hook, latch assemblies can be added.
- Load rating code stamped on each hook.



S-319N



S-319

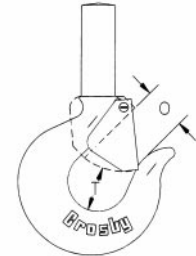
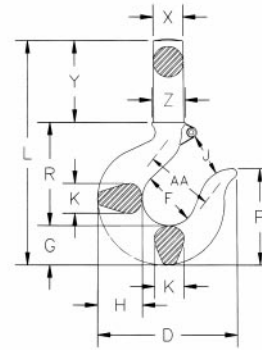


Table 4-6. Shank Hooks

Working Load Limit (tons) ①			Hook Identification Code Frame Size			Dimensions (in.)															Weight Each (lbs.)
Carbon	Alloy	Bronze	319-C 319-CN 320-C 320-CN 322-C	319-A 319-AN 320-A 320-AN 322-A	319-BN	D	F	G	H	J	K	L	M	O	P	R	T <sup>②</sup>	X	Y	Z	
.75	1	.5	DC	DA	DB	2.86	1.25	.73	.81	.93	.63 <sup>③</sup>	5.14	.63	.93	1.96	2.35	.97	.59	2.06	.69	.50
1	1.5	.6	FC	FA	FB	3.16	1.38	.84	.94	.97	.71 <sup>③</sup>	5.68	.71	.97	2.22	2.59	.97	.66	2.25	.78	.75
1.5	2	1	GC	GA	GB	3.59	1.50	1.00	1.16	1.06	.88 <sup>③</sup>	6.35	.88	1.06	2.44	2.76	1.03	.72	2.59	.88	1.00
2	3	1.4	HC	HA	HB	4.00	1.62	1.14	1.31	1.19	.94 <sup>③</sup>	7.14	.94	1.16	2.78	3.16	1.16	.88	2.84	1.00	1.82
3	5	2	IC	IA	IB	4.84	2.00	1.44	1.63	1.50	1.31	8.63	1.13	1.41	3.47	3.85	1.53	1.16	3.34	1.25	3.69
5	7	3.5	JC	JA	JB	6.28	2.50	1.82	2.06	1.78	1.66	10.43	1.44	1.69	4.59	4.77	1.94	1.41	3.84	1.56	7.25
7.5	11	5	KC	KA	KB	7.54	3.00	2.26	2.63	2.41	1.88	12.52	1.63	2.22	5.25	5.88	2.46	1.81	4.38	1.94	13.49
10	15	6.5	LC	LA	LB	8.34	3.25	2.60	2.94	2.62	2.19	13.47	1.94	2.41	5.69	6.37	2.59	2.00	4.50	2.19	18.00
15	22	10	NC	NA	NB	10.34	4.25	3.01	3.50	3.41	2.69	16.65	2.38	3.19	6.88	8.14	2.81	2.56	5.50	2.63	35.33
20	30	—	OC	OA	—	13.62	5.00	3.62	4.62	4.00	3.00	23.09	—	3.25	8.78	9.44	3.44	3.12	10.00	3.12	72.00
20	30	—	OC	OA	—	13.62	5.00	3.62	4.62	4.00	3.00	31.09	—	3.25	8.78	9.44	3.44	3.12	18.00	3.12	85.50
25	37	—	PC	PA	—	14.06	5.38	4.56	5.00	4.25	4.00	31.12	—	3.00	11.38	12.56	3.88	4.00	15.00	4.00	134.00
25	37	—	PC	PA	—	14.06	5.38	4.56	5.00	4.25	4.00	41.12	—	3.00	11.38	12.56	3.88	4.00	24.00	4.00	172.00
30	45	—	SC	SA	—	15.44	6.00	5.06	5.50	4.75	4.50	34.12	—	3.38	12.63	14.00	4.75	4.00	15.00	4.00	182.00
30	45	—	SC	SA	—	15.44	6.00	5.06	5.50	4.75	4.50	43.12	—	3.38	12.63	14.00	4.75	4.00	24.00	4.00	214.00
40	60	—	TC	TA	—	18.50	7.00	6.00	6.50	5.75	5.50	36.06	—	4.12	14.81	15.50	5.69	4.50	14.50	4.50	268.00
40	60	—	TC	TA	—	18.50	7.00	6.00	6.50	5.75	5.50	47.56	—	4.12	14.81	15.50	5.69	4.50	26.00	4.50	312.00
50	75	—	UC	UA	—	20.62	7.75	6.69	7.25	6.50	6.25	41.16	—	5.38	16.53	19.38	6.00	5.00	15.00	5.00	390.00
50	75	—	UC	UA	—	20.62	7.75	6.69	7.25	6.50	6.25	49.16	—	5.38	16.53	19.38	6.00	5.00	23.00	5.00	426.00
—	100	—	—	WA	—	23.00	6.81	8.59	9.88	5.88	5.50	42.12	—	4.50	17.38	18.41	7.00	7.00	15.00	7.00	610.00
—	100	—	—	WA	—	23.00	6.81	8.59	9.88	5.88	5.50	48.12	—	4.50	17.38	18.41	7.00	7.00	21.00	7.00	675.00
—	150	—	—	XA	—	24.38	6.75	9.12	10.94	6.00	6.00	45.75	—	4.50	18.00	18.38	7.00	7.25	18.00	7.25	735.00
—	200	—	—	YA	—	26.69	7.50	9.75	11.81	6.60	7.00	50.50	—	5.00	19.25	20.50	8.00	8.00	20.00	8.00	1,020.00
—	300	—	—	ZA	—	30.12	9.50	10.62	12.94	8.00	7.25	54.69	—	6.25	22.69	23.50	8.25	9.50	20.00	9.50	1,390.00

① Proof Load is 2.0 x Working Load Limit. All carbon hooks — average straightening load (ultimate load) is 5 x Working Load Limit. Alloy eye hooks 1 ton through 22 tons — average straightening load (ultimate load) is 5 x Working Load Limit. Alloy eye hooks 30 tons through 60 tons — average straightening load (ultimate load) is 4 x Working Load Limit. Alloy shank hooks 1 ton through 22 tons — average straightening load (ultimate load) is 4 x Working Load Limit. Alloy shank hooks 30 tons through 300 tons (ultimate load) is 4 x Working Load Limit. All Bronze hooks — average straightening load (ultimate load) is 4 x Working Load Limit.

② Dimension before machining (as forged).

③ Dimensions shown are for S-4320 latch kits. Dimensions for sizes 20 ton carbon and larger are for PL Latch Kits.



Made in the U.S.A.

### Swivel Hooks

- Forged — quenched and tempered.
- Proper design, careful forging, and precision controlled quenching and tempering gives maximum strength without excessive weight and bulk.
- Every Crosby swivel hoist hook has a predrilled cam which can be equipped with a latch. Even years after purchase of the original hook, latch assemblies can be added.
- Load rating code stamped on each hook. 322 Swivel Hooks use the same load rating code as 319 Shank Hooks.



S-322N

**Angle Indicators** — Indicates the maximum included angle which is allowed between (2) sling legs in the hook. These indicators also provide the opportunity to approximate other included angles between two sling legs.

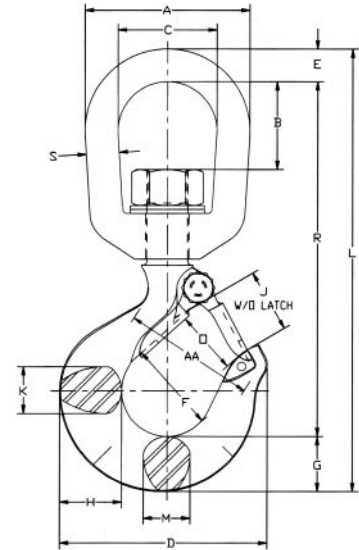


Table 4-7. Swivel Hooks

Working Load Limit ① (tons)		322 CN Stock No.	322 AN Stock No.	Weight Each (lbs.)	Dimensions (in.)														
322C ②	322A ③				A	B	C	D	F	G	H	J	K	L	M	O	R	S	
3/4 ④	1 ④	1048600	1048804	.75	2.00	.82	1.25	2.86	1.25	.75	.81	.93	.63	5.66	.56	.89	4.53	.38	
1 ④	1-1/2 ④	1048609	1048813	1.25	2.50	1.25	1.50	3.15	1.38	.84	.94	.97	.71	6.71	.63	.91	5.37	.50	
1-1/2 ④	2 ④	1048618	1048822	2.25	3.00	1.50	1.75	3.59	1.50	1.00	1.16	1.06	.88	7.75	.75	1.00	6.12	.63	
2 ④	3 ④	1048627	1048831	2.30	3.00	1.50	1.75	3.99	1.62	1.13	1.31	1.19	.94	8.25	.85	1.09	6.50	.63	
3 ④	5 ④	1048636	1048837	4.96	3.50	1.64	2.00	4.84	2.00	1.44	1.63	1.50	1.31	9.69	1.13	1.36	7.50	.75	
5 ④	7 ④	1048645	1048854	10.29	4.50	2.29	2.50	6.27	2.50	1.81	2.06	1.78	1.66	12.47	1.38	1.61	9.66	1.00	
7-1/2 ④	11 ④	1048654	1048865	16.18	5.00	2.37	2.75	7.54	3.00	2.25	2.63	2.41	1.88	14.54	1.63	2.08	11.16	1.13	
10 ④	15 ④	1048663	1048877	23.25	5.62	2.48	3.12	8.33	3.25	2.59	2.94	2.62	2.19	16.09	1.94	2.27	12.00	1.25	
15 ④	22 ④	1048672	1048886	47.00	7.10	3.76	4.10	10.38	4.25	3.00	3.50	3.41	2.69	21.22	2.38	3.02	16.59	1.50	
—	30 ⑤	—	1025688	70.50	7.00	3.75	4.00	13.62	—	3.66	—	4.00	2.86	23.22	2.86	3.25	18.06	1.50	

① Proof Load is 2 x Working Load Limit. All carbon swivel hooks — average straightening load (ultimate load) is 5 x Working Load Limit. All alloy swivel hooks — average straightening load (ultimate load) is 4.5 x Working Load Limit.

② 322C — carbon steel.

③ 322A — hook and bail — alloy steel.

④ Dimensions for hooks 3/4 ton carbon through 22 ton alloy are for 4320 latch kit.

⑤ Dimensions for hooks 30 ton alloy and larger are for PL latch kit.

**Note:** This hook is a positioning device and is not intended to rotate under load. Use in salt water requires shank and nut inspection in accordance with A.S.M.E., B10-1.2.1.1-(b)-2(c) 1996.

# FITTINGS & BLOCKS

Amick Associates, Inc.

## Hooks and Latches

version #2-04

the **Crosby** group  
inc.

Made in the U.S.A. 

### Hook Connectors

The 6 connector styles shown below make it possible for Crosby to furnish a Golden Gate Hook to fit almost any make or model of hoisting equipment including American Engineering Lo-Hed, ARO, Coffing, Electro Lift, Ingersoll-Rand, P & H, Robbins and Myers, Shepard Niles, CM, Shaw-Box, Wright, Yale & Towne.

#### Closed Swivel Bail

For use where hoisting line or shackle can be inserted into the bail.

**Hook Sizes:** 1 through 14.

**Style C:** with self-closing gate.

**Style A:** with manual-closing gate.



*Closed Swivel Bail*

#### Universal Type

Open swivel bail for attachment to link chain.

**Hook Sizes:** 3, 4 and 5.

**Style E:** with self-closing gate.

**Style G:** with manual-closing gate.



*Universal Type*

#### Shank-Type Hook (Standard Length)

For use on existing load blocks, with standard shank length.

**Hook Sizes:** 2 through 14.

**Style D:** with self-closing gate.

**Style B:** with manual-closing gate.



*Shank-Type Hook (Standard Length)*

#### Link Chain Nest

With ball-bearing swivel; attaches to chain by an alloy pin.

**Hook Sizes:** 4, 5 and 7.

**Style O:** with self-closing gate.

**Style P:** with manual-closing gate.



*Link Chain Nest*

#### Shank-Type Hook (Long Length)

For use on existing load blocks requiring extra shank length.

**Hook Sizes:** 4 through 17.

**Style K:** with self-closing gate.

**Style I:** with manual-closing gate.



*Shank-Type Hook (Long Length)*

#### Roller Chain Nest

Attachment with ball-bearing swivel and full-floating connector.

**Hook Sizes:** 4, 5 and 6.

**Style S:** with self-closing gate.

**Style R:** with manual-closing gate.



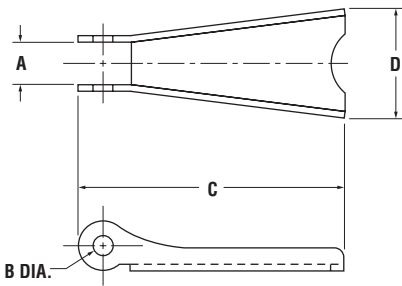
*Roller Chain Nest*

**Note:** Letter designations shown above each photo indicate BOTH connector style and gate type. Each connector is available with either a self-closing or manual-closing gate. (e.g.,: A size 4 hook with a closed swivel bail connector and self-closing gate is 4-C; with manual-closing gate, it is 4-A.)



Made in the U.S.A.

### Crosby Latch Kit



SS-4055

- Stainless steel construction with cadmium plated steel nuts.
- Shipped packaged and unassembled.
- Instructions included for easy field assembly.

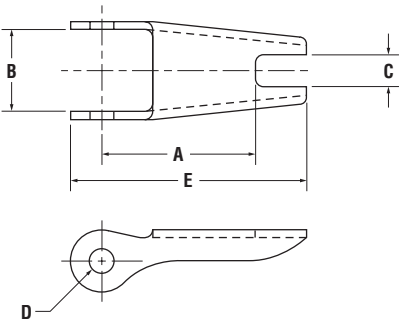
**Note:** These latches will not work on new "N" style hooks.

**Table 4-8. Crosby Latch Kit**

Hook Size (tons)			SS-4055 Stock No.	Weight Each (lbs.)	Dimensions (in.)			
Carbon	Alloy	Bronze			A	B	C	D
3/4	1	.5	1090027	.02	.38	.16	1.44	.59
1	1-1/2	.6	1090045	.02	.38	.16	1.60	.59
1-1/2 - 2	2 - 3	1.0 - 1.4	1090063	.03	.47	.19	1.84	.82
3	4-1/2	2.0	1090081	.06	.56	.17	2.41	1.00
5	7	3.5	1090107	.11	.58	.20	2.97	1.21
7-1/2 - 10	11 - 15	5.0 - 6.5	1090125	.17	.59	.27	3.66	1.50
15	22	10.0	1090143	.39	.83	.39	4.94	1.90
20	30	—	1090161	.63	.94	.52	5.88	2.56
25 - 30	37 - 45	—	1090189	1.12	2.19	.39	6.50	3.84
40	60	—	1090205	1.77	3.31	.52	7.88	4.12

### Crosby S-4320 Latch Kit

#### Replacement Latch Kit for New 319N, 320N and 322N Hooks



S-4320

- Heavy duty stamped latch interlocks with the hook tip.
- High cycle, long life spring.
- Can be made into a "Positive Locking" hook when proper cotter pin is utilized.

**Note:** The new S-4320 Latch kit will not fit the old style 319, 320 and 322 hooks.

**Table 4-9. Crosby S-4320 Latch Kit**

Hook Size (tons)			S-4320 Stock No.	Weight Each (lbs.)	Dimensions (in.)				
Carbon	Alloy	Bronze			A	B	C	D	E
3/4	1	.5	1096325	.03	.94	.50	.20	.15	1.44
1	1-1/2	.6	1096374	.04	1.00	.54	.22	.17	1.56
1-1/2	2	1	1096421	.04	1.09	.63	.23	.17	1.66
2	3	1.4	1096468	.06	1.21	.66	.28	.17	1.91
3	5	2	1096515	.10	1.53	.83	.35	.20	2.31
5	7	3.5	1096562	.15	1.88	1.04	.44	.20	2.88
7	11	5	1096609	.28	2.50	1.25	.53	.27	3.56
10	15	6.5	1096657	.33	2.62	1.35	.59	.27	3.81
15	22	10	1096704	.84	3.44	1.66	.66	.39	5.18

# FITTINGS & BLOCKS

Amick Associates, Inc.

version #2-04

## Turnbuckles

### Turnbuckles

Hot dip galvanized forged steel, all end fittings except 1/4", 5/16" and 3/8", sizes quenched and tempered, bodies heat treated by normalizing. Outstanding design features include elongated turnbuckle eyes. For turnbuckle sizes, 1/4" through 2-1/2", shackles one size smaller can be reeved through turnbuckle eye. Mod thread is an exclusive feature.

- Jaw End Fittings, sizes 1/4" through 5/8" have Bolts and Nuts.
- Jaw End Fittings, sizes 3/4" through 2-3/4" have Pins and Cotters.
- Hot dip galvanized Lock Nuts available for all sizes — R.H.-G4060, L.H.-G4061.
- Hooks not supplied on sizes larger than 1-1/2".



**HG-225 Hook and Eye**

**Note:** Meets Federal Specifications FF-T-791b Type 1 Form 1 — Class 6.



**HG-226 Eye and Eye**

**Note:** Meets Federal Specifications FF-T-791b Type 1 Form 1 — Class 4.



**HG-223 Hook and Hook**

**Note:** Meets Federal Specifications FF-T-791b Type 1 Form 1 — Class 5.



**HG-227 Jaw and Eye**

**Note:** Meets Federal Specifications FF-T-791b Type 1 Form 1 — Class 8.



**HG-228 Jaw and Jaw**

**Note:** Meets Federal Specifications FF-T-791b Type 1 Form 1 — Class 7.

**Table 4-10. Turnbuckle with Mod Thread**

Diameter and Take Up (in.)	Average Overall with Ends In Closed Position (in.)	Weight (lbs.)		
		223-225, 226 with Eyes or Hooks	HG 227 Jaw and Eye	HG 228 Jaw and Jaw
1/4 x 4 ①	8-1/4	.30	.32	.36
5/16 x 4-1/2 ①	9-9/16	.47	.47	.52
3/8 x 6 ①	11-7/8	.75	.76	.81
1/2 x 6	13-5/16	1.60	1.53	1.50
9	16-5/16	1.83	1.71	1.74
12	19-5/16	2.08	2.06	2.40
5/8 x 6	15-1/2	2.75	2.35	2.72
9	18-1/2	3.13	3.06	3.24
12	21-1/2	3.50	3.78	3.74
3/4 x 6	17	3.89	4.00	4.11
9	20	4.61	4.75	5.10
12	23	5.43	5.36	5.65
18	29	7.25	7.00	7.00
7/8 x 12	24-5/8	8.10	8.00	8.17
18	30-5/8	9.95	9.75	9.96
1 x 6	20-5/8	9.33	8.92	9.75
12	26-5/8	11.93	11.20	12.00
18	32-5/8	14.00	13.30	14.00
24	38-5/8	17.25	17.00	17.00
1-1/4 x 12	29-7/8	19.00	20.00	21.50
18	35-7/8	23.00	24.18	24.25
24	41-7/8	27.00	28.50	28.00
1-1/2 x 12	32-3/8	27.50	28.99	30.05
18	38-3/8	31.00	35.00	36.75
24	44-3/8	37.50	39.18	40.67
1-3/4 x 18	41-3/4	52.50	53.75	55.04
24	47-3/4	58.00	60.68	63.36
2 x 24	51-3/4	85.25	89.00	94.25
2-1/2 x 24	58-1/2	144.25	150.00	165.00
2-3/4 x 24	61-1/2	194.00	183.00	198.00

① Normalized.

### Wire Rope Thimbles



**G-408 (Open Pattern)**



**G-411 Standard**

**Note:** Recommended for light duty service. G-411 meets Federal Specification FF-T-276b Type II.



**SS-414 (Stainless Steel)**



**G-414 Extra Heavy**

**Note:** A rugged rope thimble recommended for heavy duty service. Thimbles G-414 meet Federal Specification FF-T-276b Type III.



**S-412 Solid**

**Note:** Fits open wire rope socket, boom pendant clevis, as well as wedge socket.

**Table 4-11. Standard Wire Rope Thimbles — Hot Dip Galvanized Steel**

For Rope Diameter (in.)	Dimensions (in.)						Weight per 100 (lbs.)
	Overall Length	Overall Width	Length Inside	Width Inside	Inside Width of Score	Maximum Pin Diameter	
1/8	1-15/16	1-1/16	1-5/16	11/16	5/32	5/8	2.50
3/16	1-15/16	1-1/16	1-5/16	11/16	7/32	5/8	2.50
1/4 ①	1-15/16	1-1/16	1-5/16	11/16	9/32	5/8	3.75
5/16 ①	2-1/8	1-1/4	1-1/2	13/16	3/8	3/4	3.75
3/8 ①	2-3/8	1-15/32	1-5/8	15/16	7/16	7/8	6.25
1/2 ①	2-3/4	1-3/4	1-7/8	1-1/8	9/16	1-1/16	12.50
5/8 ①	3-1/2	2-3/8	2-1/4	1-3/8	11/16	1-1/4	25.00
3/4	3-3/4	2-11/16	2-1/2	1-5/8	13/16	1-1/2	50.00
7/8	5	3-3/16	3-1/2	1-7/8	15/16	1-3/4	85.00
1	5-11/16	3-3/4	4-1/4	2-1/2	1-1/16	2-3/8	100.00
1-1/8 – 1-1/4	6-1/4	4-5/16	4-1/2	2-3/4	1-5/16	2-5/8	175.00

① Sizes available in open pattern.

**Table 4-12. Extra Heavy Wire Rope Thimbles — Hot Dip Galvanized and Stainless Steel**

For Rope Diameter (in.)	Dimensions (in.)						Weight per 100 (lbs.)
	Overall Length	Overall Width	Length Inside	Width Inside	Overall Thickness	Maximum Pin Diameter	
1/4 ①	2-3/16	1-1/2	1-5/8	7/8	13/32	13/16	6.75
5/16 ①	2-1/2	1-13/16	1-7/8	1-1/16	1/2	15/16	11.25
3/8 ①	2-7/8	2-1/8	2-1/8	1-1/8	21/32	1-1/16	21.00
7/16	3-1/4	2-3/8	2-3/8	1-1/4	3/4	1-3/16	30.00
1/2 ①	3-5/8	2-3/4	2-3/4	1-1/2	27/32	1-7/16	51.00
9/16	3-5/8	2-11/16	2-3/4	1-1/2	29/32	1-7/16	51.00
5/8 ①	4-1/4	3-1/8	3-1/4	1-3/4	1	1-5/8	75.00
3/4 ①	5	3-13/16	3-3/4	2	1-1/4	1-7/8	147.00
7/8	5-1/2	4-1/4	4-1/4	2-1/4	1-3/8	2-1/8	175.00
1	6-1/8	4-15/16	4-1/2	2-1/2	1-9/16	2-3/8	275.00
1-1/8 – 1-1/4	7	5-7/8	5-1/8	2-7/8	1-7/8	2-3/4	400.00
1-1/4 – 1-3/8	9-1/16	6-13/16	6-1/2	3-1/2	2-1/4	3-1/4	817.00
1-3/8 – 1-1/2	9	7-1/8	6-1/4	3-1/2	2-5/8	3-3/8	1,175.00
1-5/8	11-1/4	8-1/8	8	4	2-3/4	3-7/8	1,700.00
1-3/4	12-3/16	8-1/2	9	4-1/2	2-7/8	4-3/8	1,775.00
1-7/8 – 2	15-1/8	10-3/8	12	6	3-1/8	5-7/8	2,500.00
2-1/4	17-1/8	11-7/8	14	7	3-5/8	6-7/8	3,950.00

① Sizes available in Stainless (304) Steel.

**Table 4-13. Solid Wire Rope Thimbles**

For Rope Diameter (in.)	Dimensions (in.)				Weight per 100 (lbs.)
	Overall Length	Overall Width	Thickness	Maximum Pin Diameter	
1/2	2-13/16	2-1/8	7/8	1	.50
5/8	4-11/16	3-3/8	1-1/8	1-3/16	2.50
3/4	4-11/16	3-3/8	1-3/8	1-3/8	2.25
7/8	6-1/16	4-1/2	1-5/8	1-5/8	6.00
1	6-1/16	4-1/2	1-13/16	2	5.12
1-1/8	7-1/4	5-3/8	2-1/16	2-1/4	10.00
1-1/4 – 1-3/8	7-1/4	5-3/8	2-5/16	2-1/2	10.00

# FITTINGS & BLOCKS

Amick Associates, Inc.

## End Fittings, Swage and Spelter Sockets

version #2-04



Made in the U.S.A.

## End Fittings, Swage and Spelter Sockets

### National Swage Buttons

- Special processed, low carbon steel.
- "Cold-Tuff®" for better swageability.
- Swage Button terminations have an efficiency rating of 98% based on the catalog strength of wire rope.
- Stamp for identification after swaging (as per directions in National Swaging Brochure).

**Note:** S-409 Buttons are recommended for use with 6 x 19 or 6 x 37, IPS or XIP (EIP), RRL, FC or IWRC wire rope. Before using any National Swage fitting with any other type lay, construction or grade of wire rope, it is recommended that the termination be destructive tested and documented to prove the adequacy of the assembly to be manufactured.



S-409

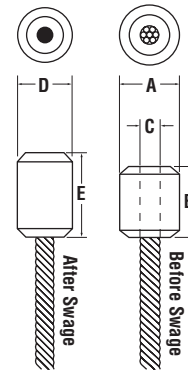


Table 4-14. S-409 Cold-Tuff® Buttons

S-409 Steel Swage Button Specifications									Press/Die Data	
S-409 Stock No.	Size No.	Rope Size (in.)	Weight per 100 Pcs. (lbs.)	Before Swage Dimensions			After Swage Dimensions		Die Description	Stock No. 500 Tons 1,000 Tons 1,500 Tons 5 x 7
				A	B	C	D Maximum After Swage Dimensions	E Length ①		
1040171	1 SB	1/8	2	.44	.50	.14	.40	.61	1/8 – 1/4 Button	1191621
1040215	3 SB	3/16	4	.56	.70	.20	.52	.84	1/4 1st Stage	1197528
1040251	5 SB	1/4	8	.63	1.06	.30	.58	1.20	1/8 – 1/4 Button	1191621
1040297	7 SB	5/16	16	.88	1.13	.36	.77	1.33	3/8 1st Stage	1192364
1040313	8 SB	3/8	15	.88	1.48	.42	.77	1.69	3/8 1st Stage	1192364
1040331	9 SB	7/16	30	1.13	1.63	.48	1.03	1.94	1/2 1st Stage	1192408
1040359	10 SB	1/2	50	1.31	1.89	.55	1.16	2.17	5/8 Socket	1192907
1040377	11 SB	9/16	70	1.44	2.02	.61	1.29	2.41	9/16 – 5/8 Button	1191665
1040395	12 SB	5/8	100	1.56	2.42	.67	1.42	2.89	9/16 – 5/8 Button	1191665
1040411	13 SB	3/4	131	1.69	2.73	.79	1.55	3.25	3/4 1st Stage	1192462
1040439	14 SB	7/8	220	2.00	3.27	.94	1.80	3.86	7/8 1st Stage	1192480
1040457	15 SB	1	310	2.25	3.67	1.06	2.05	4.36	1 1st Stage	1192505
1040475	16 SB	1-1/8	450	2.56	4.05	1.19	2.30	4.81	1-1/8 1st Stage	1192523
1040493	17 SB	1-1/4	650	2.81	4.58	1.33	2.56	5.42	1-3/8 Socket	1193023

① Length is measured from outside end of termination.

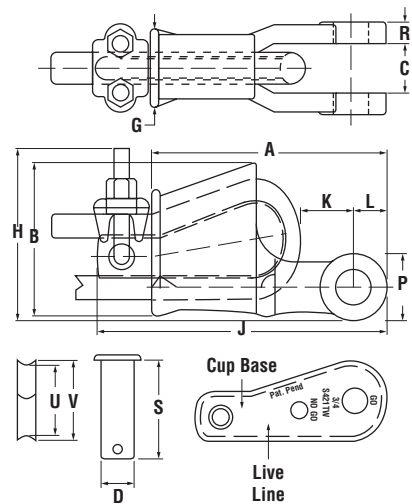
### S-421T Wedge Sockets

- Basket is cast steel.
- Individually magnetic particle inspected.
- Pin diameter and jaw opening allows wedge and socket to be used in conjunction with open swage and spelter sockets.
- Secures the tail or "dead end" of the wire rope to the wedge, thus eliminates loss or "punch out" of the wedge.
- Eliminates the need for an extra piece of rope, and is easily installed.
- The TERMINATOR™ wedge eliminates the potential breaking off of the tail due to fatigue.
- The tail, which is secured by the base of the clip and the wedge, is left undeformed and available for reuse.
- Incorporates Crosby's patented QUIC-CHECK® "Go" and "Non-Go" feature cast into the wedge. The proper size rope is determined when the following criteria are met:
  - The wire rope should pass through the "Go" hole in the wedge.
  - The wire rope should NOT pass through the "No-Go" hole in the wedge.
- Utilizes standard Crosby Red-U-Bolt® wire rope clip.
- Wedge socket terminations have an efficiency rating of 80% based on the catalog strength of XXIP wire rope.
- Standard S-421 wedge socket can be retrofitted with the new style TERMINATOR wedge.
- Available with Bolt, Nut and Cotter Pin.
- U.S. patent 5,553,360 and foreign equivalents.

**Note:** Wedge sockets meet the performance requirements of Federal Specification RR-S-550D, Type C, except those provisions required of the contractor.



S-421T



**Table 4-15. S-421T Wedge Sockets**

Wire Rope Diameter (in.) <sup>①</sup>	S-421T Stock No. <sup>①</sup>	Weight Each (lbs.)	S-421 TW Stock No. Wedge Only	Wedge Only Weight Each (lbs.)	Dimensions (in.)														
					A	B	C	D	G	H	J <sup>②</sup>	K <sup>②</sup>	L	P	R	S	T	U	V
3/8	1035000	3.18	1035555	.50	5.63	2.77	.81	.81	1.38	3.12	7.38	1.60	.88	1.56	.44	2.13	.44	1.25	1.38
1/2	1035009	6.15	1035564	1.05	6.81	3.55	1.00	1.00	1.62	3.85	8.75	1.21	1.06	1.94	.50	2.44	.53	1.75	1.88
5/8	1035018	9.70	1035573	1.79	8.16	4.36	1.25	1.19	2.12	4.58	10.34	1.64	1.22	2.25	.56	3.13	.69	2.00	2.19
3/4	1035027	14.50	1035582	2.60	9.78	4.81	1.50	1.38	2.44	5.37	12.03	2.17	1.40	2.62	.66	3.63	.78	2.34	2.56
7/8	1035036	21.50	1035591	4.02	11.16	4.65	1.75	1.63	2.69	6.28	14.00	2.22	1.66	3.12	.75	4.19	.88	2.69	2.94
1	1035045	30.75	1035600	5.37	12.75	5.08	2.00	2.00	2.56	7.02	15.86	2.71	2.00	3.75	.88	4.63	1.03	2.88	3.28
1-1/8	1035054	45.30	1035609	7.84	14.38	5.51	2.25	2.25	3.31	7.76	17.70	2.50	2.25	4.25	1.00	5.38	1.19	3.13	3.56
1-1/4 <sup>③</sup>	1040448	57.50	1040607	6.81	16.00	7.94	2.50	2.50	3.56	N/A	N/A	3.39	2.50	4.75	1.12	5.81	1.31	3.38	3.81

① TERMINATOR assembly includes Socket, Wedge, Pin and Wire Rope Clip.

② 1-1/4 not available in TERMINATOR style.

③ Nominal.

# FITTINGS & BLOCKS

Amick Associates, Inc.

## End Fittings, Swage and Spelter Sockets

version #2-04



Made in the U.S.A.

### Open Swage Sockets

- Forged from special bar quality carbon steel, suitable for cold forming.
- Hardness controlled by spheroidize annealing.
- Swage Socket terminations have an efficiency rating of 100% based on the catalog strength of wire rope.
- Stamp for identification after swaging without concern for fractures (as per directions in National Swaging Brochure).
- Swage sockets incorporate a reduced machined area of the shank which is equivalent to the proper "After Swage" dimension (see arrow and photo on right). Before swaging, this provides for an obvious visual difference in the shank diameter. After swaging, a uniform shank diameter is created allowing for a QUIC-CHECK® and permanent visual inspection opportunity.
- Designed to quickly determine whether the socket has been through the swaging operation and assist in field inspections, it does not eliminate the need to perform standard production inspections which include gauging for the proper "After Swage" dimensions or proof loading.
- U.S. Patent 5,152,630 and foreign equivalents.

**Note:** S-501 Swage Sockets are recommended for use with 6 x 19 or 6 x 37, IPS or XIP (EIP), XXIP (EPIP), RRL, FC or IWRC wire rope. Before using any National Swage fitting with any other type lay, construction or grade of wire rope, it is recommended that the termination be destructive tested and documented to prove the adequacy of the assembly to be manufactured. In accordance with ANSI B30.9, all slings terminated with swage sockets shall be proof loaded. Maximum Proof Load shall not exceed 50% of XXIP rope catalog breaking strength.



S-501

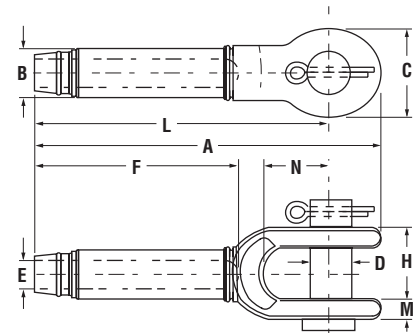


Table 4-16. S-501 Open Swage Sockets

S-501 Open Socket Specifications													Press/Die Data					
S-501 Stock No.	Rope Size (in.) ①	Weight Each (lbs.)	Before Swage Dimensions										Max. After Swage Dim. (in.)	Die Description	Stock No.		Side Load	
			A	B	C	D	E	F	H	L	M	N			500 Tons 5 x 7	1,500 Tons 6 x 12	1,500 Tons 6 x 12	3,000 Tons 6 x 12
1039021	1/4	.52	4.81	.50	1.38	.69	.27	2.13	.69	4.00	.38	1.50	.46	1/4 Socket	1192845	—	—	—
1039049	5/16	1.12	6.25	.77	1.62	.81	.34	3.19	.81	5.31	.47	1.75	.71	5/16 – 3/8 Socket	1192863	—	—	—
1039067	3/8	1.30	6.25	.77	1.62	.81	.41	3.19	.81	5.31	.47	1.75	.71	5/16 – 3/8 Socket	1192863	—	—	—
1039085	7/16	2.08	7.81	.98	2.00	1.00	.48	4.25	1.00	6.69	.56	2.00	.91	7/16 – 1/2 Socket	1192881	—	—	—
1039101	1/2	2.08	7.81	.98	2.00	1.00	.55	4.25	1.00	6.69	.56	2.00	.91	7/16 – 1/2 Socket	1192881	—	—	—
1039129	9/16	4.67	9.50	1.25	2.38	1.19	.61	5.31	1.25	8.13	.68	2.25	1.16	9/16 – 5/8 Socket	1192907	—	—	—
1039147	5/8	4.51	9.50	1.25	2.38	1.19	.67	5.31	1.25	8.13	.68	2.25	1.16	9/16 – 5/8 Socket	1192907	—	—	—
1039165	3/4	7.97	11.56	1.55	2.75	1.38	.80	6.38	1.50	10.00	.78	2.75	1.42	3/4 Socket	1192925	—	—	—
1039183	7/8	11.52	13.41	1.70	3.13	1.62	.94	7.44	1.75	11.63	.94	3.25	1.55	7/8 Socket	1192949	—	—	—
1039209	1	17.80	15.47	1.98	3.69	2.00	1.06	8.50	2.00	13.38	1.06	3.75	1.80	1 Socket	1192961	—	—	—
1039227	1-1/8	25.25	17.31	2.25	4.06	2.25	1.19	9.56	2.25	15.00	1.19	4.25	2.05	1-1/8 Socket	1192989	—	—	—
1039245	1-1/4	35.56	19.06	2.53	4.50	2.50	1.33	10.63	2.50	16.50	1.22	4.75	2.30	1-1/4 Socket	1193005	—	—	—
1039263	1-3/8	43.75	20.94	2.80	5.00	2.50	1.45	11.69	2.50	18.13	1.38	5.25	2.56	1-3/8 Socket	1193023	—	—	—
1039281	1-1/2	58.50	22.88	3.08	5.50	2.75	1.58	12.75	3.00	19.75	1.69	5.75	2.81	1-1/2 Socket	1193041	1191267	1195355	1195192
1039307	1-3/4	88.75	26.63	3.39	6.69	3.50	1.86	14.88	3.50	23.00	2.11	6.75	3.06	1-3/4 Socket	1193069	1191276	1195367	1195209
1042767	2	146.2	31.44	3.94	8.00	3.75	2.11	17.00	4.00	26.88	2.37	8.00	3.56	2 Socket	1193087	1191294	1195379	1195218

① Maximum Proof Load shall not exceed 50% of XXIP rope catalog breaking strength.

### Closed Swage Sockets

- Forged from special bar quality carbon steel, suitable for cold forming.
- Hardness controlled by spheroidize annealing.
- Swage Socket terminations have an efficiency rating of 100% based on the catalog strength of wire rope.
- Stamp for identification after swaging without concern for fractures (as per directions in National Swaging Brochure).
- Swage sockets incorporate a reduced machined area of the shank which is equivalent to the proper "After Swage" dimension (see arrow and photo on right). Before swaging, this provides for an obvious visual difference in the shank diameter. After swaging, a uniform shank diameter is created allowing for a QUIC-CHECK® and permanent visual inspection opportunity.
- Designed to quickly determine whether the socket has been through the swaging operation and assist in field inspections, it does not eliminate the need to perform standard production inspections which include gauging for the proper "After Swage" dimensions or proof loading.
- U.S. Patent 5,152,630 and foreign equivalents.

**Note:** S-502 Swage Sockets are recommended for use with 6 x 19 or 6 x 37, IPS or XIP (EIP), XXIP (EEIP), RRL, FC or IWRC wire rope. Before using any National Swage fitting with any other type lay, construction or grade of wire rope, it is recommended that the termination be destructive tested and documented to prove the adequacy of the assembly to be manufactured. In accordance with ANSI B30.9, all slings terminated with swage sockets shall be proof loaded.



S-502

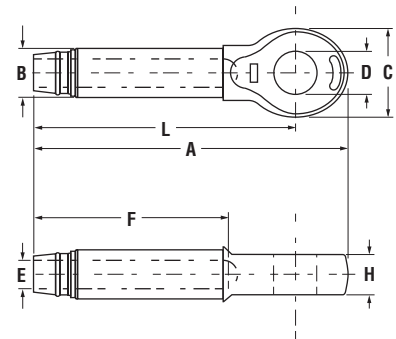


Table 4-17. S-502 Closed Swage Sockets

S-502 Closed Socket Specifications												Press/Die Data				
S-502 Stock No.	Rope Size (in.) ①	Weight Each (lbs.)	Before Swage Dimensions								Max. After Swage Dim. (in.)	Die Description	Stock No.		Side Load	
			A	B	C	D	E	F	H	L			500 1,000 1,500 Tons 5 x 7	1,500 3,000 Tons 6 x 12	1,500 Tons 6 x 12	3,000 Tons 6 x 12
1039325	1/4	.33	4.31	.50	1.38	.75	.27	2.12	.50	3.50	.46	1/4 Socket	1192845	—	—	—
1039343	5/16	.75	5.44	.77	1.62	.88	.34	3.19	.67	4.50	.71	5/16 – 3/8 Socket	1192863	—	—	—
1039361	3/8	.72	5.44	.77	1.62	.88	.41	3.19	.67	4.50	.71	5/16 – 3/8 Socket	1192863	—	—	—
1039389	7/16	1.42	6.91	.98	2.00	1.06	.48	4.25	.86	5.75	.91	7/16 – 1/2 Socket	1192881	—	—	—
1039405	1/2	1.42	6.91	.98	2.00	1.06	.55	4.25	.86	5.75	.91	7/16 – 1/2 Socket	1192881	—	—	—
1039423	9/16	2.92	8.66	1.25	2.38	1.25	.61	5.31	1.13	7.25	1.16	9/16 – 5/8 Socket	1192907	—	—	—
1039441	5/8	2.85	8.66	1.25	2.38	1.25	.67	5.31	1.13	7.25	1.16	9/16 – 5/8 Socket	1192907	—	—	—
1039469	3/4	5.00	10.28	1.55	2.88	1.44	.80	6.38	1.31	8.63	1.42	3/4 Socket	1192925	—	—	—
1039487	7/8	6.80	11.94	1.70	3.12	1.69	.94	7.44	1.50	10.13	1.55	7/8 Socket	1192949	—	—	—
1039502	1	10.40	13.56	1.98	3.63	2.06	1.06	8.50	1.75	11.50	1.80	1 Socket	1192961	—	—	—
1039520	1-1/8	14.82	15.03	2.25	4.00	2.31	1.19	9.56	2.00	12.75	2.05	1-1/8 Socket	1192989	—	—	—
1039548	1-1/4	21.57	16.94	2.53	4.50	2.56	1.33	10.63	2.25	14.38	2.30	1-1/4 Socket	1193005	—	—	—
1039566	1-3/8	28.54	18.63	2.80	5.00	2.56	1.45	11.69	2.25	15.75	2.56	1-3/8 Socket	1193023	—	—	—
1039584	1-1/2	38.06	20.12	3.08	5.50	2.81	1.58	12.75	2.50	17.00	2.81	1-1/2 Socket	1193041	1191267	1193355	1195192
1039600	1-3/4	51.00	23.56	3.39	6.25	3.56	1.86	14.88	3.00	20.00	3.06	1-3/4 Socket	1193069	1191276	1195367	1195209
1042589	2	89.25	27.62	3.94	7.25	3.81	2.11	17.00	3.25	23.00	3.56	2 Socket	1193087	1191294	1195379	1195218

① Maximum Proof Load shall not exceed 50% of XXIP rope catalog breaking strength.

# FITTINGS & BLOCKS

Amick Associates, Inc.

## End Fittings, Swage and Spelter Sockets

version #2-04

the **Grosby** group  
inc.

Made in the U.S.A. 

### Open Spelter Sockets

- Forged Steel Sockets through 1-1/2", cast alloy steel 1-5/8" through 4".
- Spelter socket terminations have an efficiency rating of 100%, based on the catalog strength of wire rope. Ratings are based on recommended use with 6 x 7, 6 x 19, or 6 x 37, IPS or XIP (EIP), XXIP (EEIP), RRL, FC, or IWRC wire rope.
- Open Grooved Sockets meet the performance requirements of Federal Specification RR-S-550D, Type A, except for those provisions required of the contractor.

**Note:** All cast steel sockets 1-5/8" and larger are magnetic particle inspected and ultrasonic inspected. Proof testing available on special order. Drawing illustrates one groove used on sockets 1/4" through 3/4". Sizes 7/8" through 1-1/2" use 2 grooves. Sizes 1-5/8" and larger use 3 grooves.



G-416 / S-416

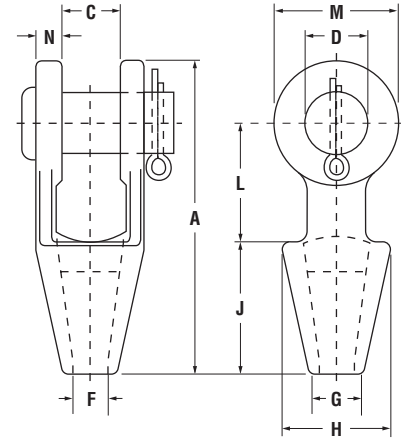


Table 4-18. G-416 / S-416 Open Spelter Sockets

Rope Diameter (in.)	Structural Strand Diameter (in.)	Stock No.		Weight Each (lbs.)	Dimensions (in.)									
		G-416 Galv.	S-416 S.C.		A	C	D	F	G	H	J	L	M	N
1/4	—	1039619	1039628	1.10	4.56	.75	.69	.38	.69	1.56	2.25	1.56	1.31	.36
5/16 – 3/8	—	1039637	1039646	1.30	4.84	.81	.81	.50	.81	1.69	2.25	1.75	1.50	.44
7/16 – 1/2	—	1039655	1039664	2.25	5.56	1.00	1.00	.56	.94	1.88	2.50	2.00	1.88	.50
9/16 – 5/8	1/2	1039673	1039682	3.60	6.75	1.25	1.19	.69	1.13	2.25	3.00	2.50	2.25	.56
3/4	9/16 – 5/8	1039691	1039708	5.83	7.94	1.50	1.38	.81	1.25	2.62	3.50	3.00	2.62	.62
7/8	11/16 – 3/4	1039717	1039726	9.65	9.25	1.75	1.63	.94	1.50	3.25	4.00	3.50	3.13	.80
1	13/16 – 7/8	1039735	1039744	15.50	10.56	2.00	2.00	1.13	1.75	3.75	4.50	4.00	3.75	.88
1-1/8	15/16 – 1	1039753	1039762	21.50	11.81	2.25	2.25	1.25	2.00	4.12	5.00	4.62	4.12	1.00
1-1/4 – 1-3/8	1-1/16 – 1-1/8	1039771	1039780	31.00	13.19	2.50	2.50	1.50	2.25	4.75	5.50	5.00	4.75	1.13
1-1/2	1-3/16 – 1-1/4	1039799	1039806	47.25	15.12	3.00	2.75	1.63	2.75	5.25	6.00	6.00	5.38	1.19
1-5/8 ①	1-5/16 – 1-3/8	1039815	1039824	55.00	16.25	3.00	3.00	1.75	3.00	5.50	6.50	6.50	5.75	1.31
1-3/4 – 1-7/8 ①	1-7/16 – 1-5/8	1039833	1039842	82.00	18.25	3.50	3.50	2.00	3.13	6.38	7.50	7.00	6.50	1.56
2 – 2-1/8 ①	1-11/16 – 1-3/4	1039851	1039860	129.00	21.50	4.00	3.75	2.25	3.75	7.38	8.50	9.00	7.00	1.81
2-1/4 – 2-3/8 ①	1-13/16 – 1-7/8	1039879	1039888	167.00	23.50	4.50	4.25	2.50	4.00	8.25	9.00	10.00	7.75	2.13
2-1/2 – 2-5/8 ①	1-15/16 – 2-1/8	1041633	1041642	252.00	25.50	5.00	4.75	2.88	4.50	9.25	9.75	10.75	8.50	2.38
2-3/4 – 2-7/8 ①	2-3/16 – 2-7/16	1041651	1041660	315.00	27.25	5.25	5.00	3.12	4.88	10.50	11.00	11.00	9.00	2.88
3 – 3-1/8 ①	2-1/2 – 2-5/8	1041679	1041688	380.00	29.00	5.75	5.25	3.38	5.25	11.12	12.00	11.25	9.50	3.00
3-1/4 – 3-3/8 ①	2-3/4 – 2-7/8	1041697	1041704	434.00	30.88	6.25	5.50	3.62	5.75	11.88	13.00	11.75	10.00	3.12
3-1/2 – 3-5/8 ①	3 – 3-1/8	1041713	1041722	563.00	33.25	6.75	6.00	3.88	6.50	12.38	14.00	12.50	10.75	3.25
3-3/4 – 4 ①	—	1041731	1041740	783.00	36.25	7.50	7.00	4.25	7.25	13.62	15.00	13.50	12.50	3.50

① Cast alloy steel.

### Closed Spelter Sockets

- Forged Steel Sockets through 1-1/2", cast alloy steel 1-5/8" through 4".
- Spelter socket terminations have an efficiency rating of 100%, based on the catalog strength of wire rope. Ratings are based on recommended use with 6 x 7, 6 x 19, or 6 x 37, IPS or XIP (EIP), XXIP (EEIP), RRL, FC, or IWRC wire rope.
- Closed Grooved Sockets meet the performance requirements of Federal Specification RR-S-550D, Type B, except for those provisions required of the contractor.

**Note:** All cast steel sockets 1-5/8" and larger are magnetic particle inspected and ultrasonic inspected. Proof testing available on special order. Drawing illustrates one groove used on sockets 1/4" through 3/4". Sizes 7/8" through 1-1/2" use 2 grooves. Sizes 1-5/8" and larger use 3 grooves.



G-417 / S-417

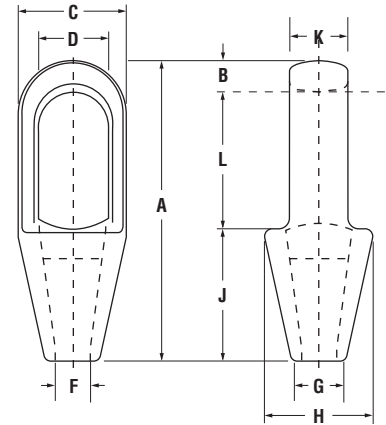


Table 4-19. G-417 / S-417 Closed Spelter Sockets

Rope Diameter (in.)	Structural Strand Diameter (in.)	Stock No.		Weight Each (lbs.)	Dimensions (in.)										
		G-417 Galv.	S-417 S.C.		A	B	C	D <sup>②</sup>	F	G	H	J	K	L	
1/4	—	1039897	1039904	.50	4.50	.50	1.50	.88	.38	.69	1.56	2.25	.50	1.75	
5/16 – 3/8	—	1039913	1039922	.75	4.88	.62	1.69	.97	.50	.81	1.69	2.25	.69	2.00	
7/16 – 1/2	—	1039931	1039940	1.50	5.44	.69	2.00	1.16	.56	.94	1.88	2.50	.88	2.25	
9/16 – 5/8	1/2	1039959	1039968	2.50	6.31	.81	2.63	1.41	.69	1.12	2.38	3.00	1.00	2.50	
3/4	9/16 – 5/8	1039977	1039986	4.25	7.56	1.06	3.00	1.66	.81	1.25	2.75	3.56	1.25	3.00	
7/8	11/16 – 3/4	1039995	1040000	7.25	8.75	1.25	3.63	1.88	.94	1.50	3.25	4.00	1.50	3.50	
1	13/16 – 7/8	1040019	1040028	10.50	9.88	1.38	4.13	2.30	1.13	1.75	3.75	4.44	1.75	4.00	
1-1/8	15/16 – 1	1040037	1040046	14.25	11.00	1.50	4.50	2.56	1.25	2.00	4.13	5.00	2.00	4.50	
1-1/4 – 1-3/8	1-1/16 – 1-1/8	1040055	1040064	19.75	12.12	1.63	5.30	2.81	1.50	2.25	4.75	5.50	2.25	5.00	
1-1/2	1-3/16 – 1-1/4	1040073	1040082	29.20	13.94	1.94	5.33	3.19	1.63	2.75	5.25	6.00	2.50	6.00	
1-5/8 <sup>①</sup>	1-5/16 – 1-3/8	1040091	1040108	36.00	15.13	2.13	5.75	3.25	1.75	3.00	5.50	6.50	2.75	6.50	
1-3/4 – 1-7/8 <sup>①</sup>	1-7/16 – 1-5/8	1040117	1040126	57.25	17.25	2.19	6.75	3.75	2.00	3.13	6.38	7.50	3.00	7.56	
2 – 2-1/8 <sup>①</sup>	1-11/16 – 1-3/4	1040135	1040144	79.00	19.50	2.44	7.63	4.38	2.25	3.75	7.38	8.50	3.25	8.56	
2-1/4 – 2-3/8 <sup>①</sup>	1-13/16 – 1-7/8	1040153	1040162	105.00	21.13	2.63	8.50	5.00	2.50	4.00	8.25	9.00	3.63	9.50	
2-1/2 – 2-5/8 <sup>①</sup>	1-15/16 – 2-1/8	1041759	1041768	140.00	23.50	3.12	9.50	5.50	2.88	4.50	9.25	9.75	4.00	10.62	
2-3/4 – 2-7/8 <sup>①</sup>	2-3/16 – 2-7/16	1041777	1041786	220.00	25.38	3.12	10.75	6.25	3.12	4.88	10.19	11.00	4.88	11.25	
3 – 3-1/8 <sup>①</sup>	2-1/2 – 2-5/8	1041795	1041802	276.00	27.00	3.25	11.50	6.75	3.38	5.25	11.50	12.00	5.25	11.75	
3-1/4 – 3-3/8 <sup>①</sup>	2-3/4 – 2-7/8	1041811	1041820	313.00	29.25	4.00	12.25	7.25	3.62	5.75	12.25	13.00	5.75	12.25	
3-1/2 – 3-5/8 <sup>①</sup>	3 – 3-1/8	1041839	1041848	400.00	31.00	4.00	13.00	7.75	3.88	6.50	13.00	14.00	6.25	13.00	
3-3/4 – 4 <sup>①</sup>	—	1041857	1041866	542.00	33.25	4.25	14.25	8.50	4.25	7.25	14.25	15.00	7.00	14.00	

<sup>①</sup> Cast alloy steel.

<sup>②</sup> Diameter of pin must not exceed pin used on companion 416 socket. Reference adjacent page "D" dimension.

# FITTINGS & BLOCKS

Amick Associates, Inc.

## Pad Eyes, Eye Nuts and Hoist Rings

version #2-04



Made in the U.S.A.

### Pad Eyes, Eye Nuts and Hoist Rings

#### Pad Eyes

- Forged from 1035 carbon steel with excellent qualities for welding.
- Widely used on farm machinery, trucks, steel-hulled marine vessels, and material handling equipment.

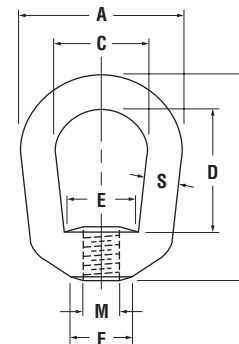
**Table 4-20. Pad Eyes — Forged Steel, Quenched and Tempered except Size No. 0 is as forged.**

Size No.	Inside Diameter of Eye (in.)	Outside Diameter of Eye (in.)	Diameter of Shoulder (in.)	Overall Height (in.)	Weight Per 100 (lbs.)
0 <sup>①</sup>	1/4	5/8	5/8	3/4	2.77
1 <sup>①</sup>	3/8	7/8	7/8	1-1/32	6.94
1-1/2 <sup>①</sup>	5/8	1-1/8	1	1-5/16	10.25
2	3/4	1-1/2	1-1/16	1-5/8	17.25
4	1	2-1/8	1-7/16	2-11/32	50.00
5	1-1/4	2-5/8	1-3/4	2-3/4	82.50

<sup>①</sup> Meets Military Specification MS-51930A.



S-264 Pad Eyes



G-400 Eye Nuts

#### Eye Nuts

**Table 4-21. Eye Nuts — Forged Steel, Hot Dip Galvanized, Threaded, Quenched and Tempered**

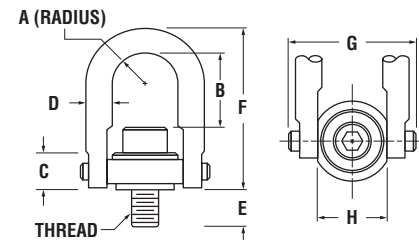
Size No.	Standard Tap M	Dimensions (in.)							Maximum Tap Size Possible	Weight (lbs.)	Working Load Limit <sup>①</sup> (lbs.)
		A	C	D	E	F	S	T			
1	1/4	1-1/14	3/4	1-1/16	21/32	1/2	1/4	1-11/16	3/8	.09	520
1A	5/16	1-1/4	3/4	1-1/16	21/32	1/2	1/4	1-11/16	3/8	.09	850
2	3/8	1-5/8	1	1-1/4	3/4	9/16	5/16	2-1/16	7/16	.18	1,250
3	7/16	2	1-1/4	1-1/2	1	13/16	3/8	2-1/2	1/2	.29	1,700
3A	1/2	2	1-1/4	1-1/2	1	13/16	3/8	2-1/2	—	.28	2,250
4	5/8	2-1/2	1-1/2	2	1-3/16	1	1/2	3-3/16	3/4	.58	3,600
5	3/4	3	1-3/4	2-3/8	1-3/8	1-1/8	5/8	3-7/8	7/8	1.00	5,200
6	7/8	3-1/2	2	2-5/8	1-5/8	1-5/16	3/4	4-5/16	1	1.70	7,200
7	1	4	2-1/4	3-1/16	1-7/8	1-9/16	7/8	5	1-1/4	2.75	10,000
7A	1-1/8	4	2-1/4	3-1/16	1-7/8	1-9/16	7/8	5	1-1/4	2.75	12,300
8	1-1/4	4-1/2	2-1/2	3-1/2	1-15/16	1-7/8	1	5-3/4	1-1/2	3.85	15,500
9	1-3/8	5	2-3/4	3-3/4	2	2	1-1/8	6-1/4	1-1/2	5.00	18,500
10	1-1/2	5-5/8	3-1/8	4	2-3/8	2-1/4	1-1/4	6-3/4	1-3/4	6.70	22,500
11	2	7	4	6-1/4	4	3-3/8	1-1/2	10	2-3/4	18.70	40,000

<sup>①</sup> Ultimate Load is 5 x the Working Load Limit.

**Note:** Order eye nuts by size number.

#### Hoist Rings

- Working action: 360 degrees swivel, 180 degrees pivot.
- Material: AISI 4140 aircraft quality.
- Finish: black oxide per mil spec; Cadmium plated.
- Safety factor: 5:1.
- 100% magnetic particle inspected.
- Certified heat treatment.



Actek Safety Hoist Ring

**Table 4-22. ACTEK Safety Hoist Rings**

Rated Loads (lbs.)	Thread Size (in.)	A	C	D	E	Standard U-Bar			Long U-Bar			G	H	Torque Ft/#	Weight (lbs.)
						Part No.	B	F	Part No.	B	F				
600	1/4 - 20	0.43	0.71	3/8	0.54	46100	1.27	2.67	—	—	—	1.84	1.00	6	0.3
800	5/16 - 18	0.43	0.71	3/8	0.29	46102	1.27	2.67	—	—	—	1.84	1.00	7	0.3
800	5/16 - 18	0.43	0.71	3/8	0.54	46104	1.27	2.67	—	—	—	1.84	1.00	7	0.3
1,000	3/8 - 16	0.43	0.71	3/8	0.54	46106	1.27	2.67	—	—	—	1.84	1.00	12	0.3
2,000	7/16 - 14	0.70	0.93	1/2	1.07	46606	1.84	3.77	—	—	—	2.58	1.49	22	1.0
2,500	1/2 - 13	0.70	0.93	1/2	1.07	46602	1.84	3.77	—	—	—	2.58	1.49	28	1.0
2,000	7/16 - 14	0.88	1.22	3/4	0.78	46000	2.31	4.78	46638	4.25	6.72	3.52	1.99	22	2.6
2,500	1/2 - 13	0.88	1.22	3/4	0.78	46008	2.31	4.78	46644	4.25	6.72	3.52	1.99	28	2.6
2,500	1/2 - 13	0.88	1.22	3/4	1.03	46010	2.31	4.78	46646	4.25	6.72	3.52	1.99	28	2.6
2,500	1/2 - 13	0.88	1.22	3/4	1.28	46012	2.31	4.78	46648	4.25	6.72	3.52	1.99	28	2.6
4,000	5/8 - 11	0.88	1.22	3/4	0.78	46002	2.18	4.78	—	—	—	3.52	1.99	60	2.6
4,000	5/8 - 11	0.88	1.22	3/4	1.03	46004	2.18	4.78	46640	4.12	6.72	3.52	1.99	60	2.6
4,000	5/8 - 11	0.88	1.22	3/4	1.28	46006	2.18	4.78	46642	4.12	6.72	3.52	1.99	60	2.6
5,000	3/4 - 10	0.88	1.22	3/4	1.03	46014	2.06	4.78	46650	4.00	6.72	3.52	1.99	100	3.0
5,000	3/4 - 10	0.88	1.22	3/4	1.53	46018	2.06	4.78	46654	4.00	6.72	3.52	1.99	100	3.0
7,000	3/4 - 10	1.40	1.71	1	1.04	46204	3.06	6.52	46658	4.65	8.11	5.14	3.00	100	7.0
7,000	3/4 - 10	1.40	1.71	1	1.54	46206	3.06	6.52	46660	4.65	8.11	5.14	3.00	100	7.0
8,000	7/8 - 9	1.40	1.71	1	1.04	46202	2.93	6.52	46656	4.52	8.11	5.14	3.00	160	7.0
8,000	7/8 - 9	1.40	1.71	1	1.29	46203	2.93	6.52	46652	4.52	8.11	5.14	3.00	160	7.0
10,000	1 - 8	1.40	1.71	1	1.29	46210	2.81	6.52	46662	4.40	8.11	5.14	3.00	230	7.5
10,000	1 - 8	1.40	1.71	1	1.54	46212	2.81	6.52	46664	4.40	8.11	5.14	3.00	230	7.5
10,000	1 - 8	1.40	1.71	1	2.29	46214	2.81	6.52	46666	4.40	8.11	5.14	3.00	230	7.5
15,000	1-1/4 - 7	1.75	2.11	1-1/4	1.89	46802	4.12	8.73	—	—	—	6.50	3.76	470	14.0
20,000	1-3/8 - 6	2.00	2.36	1-1/2	2.64	46702	5.20	10.59	—	—	—	7.46	4.31	540	22.0
24,000	1-1/2 - 6	2.25	2.81	1-3/4	2.70	46404	6.41	12.47	—	—	—	8.55	4.87	800	34.0
24,000	1-3/4 - 5	2.25	2.81	1-3/4	2.70	46408	6.41	12.47	—	—	—	8.55	4.87	800	34.0
30,000	2 - 4-1/2	2.25	2.81	1-3/4	2.96	46400	5.91	12.47	—	—	—	8.55	4.87	800	36.0
50,000	2-1/2 - 8	3.00	4.09	2-1/4	4.00	47002	8.03	16.87	—	—	—	11.67	6.52	2,100	88.0
50,000	2-1/2 - 4	3.00	4.09	2-1/4	4.00	47006	8.03	16.87	—	—	—	11.67	6.52	2,100	88.0
75,000	3 - 4	3.75	5.27	2-3/4	5.00	47200	8.48	19.50	—	—	—	14.15	8.10	4,300	166.0
100,000	3-1/2 - 4	4.00	6.06	3-1/4	7.00	47402	9.28	22.09	—	—	—	15.90	8.60	5,100	265.0
250,000	6 - 4	6.00	14.00	5	9.00	47602	14.00	33.00	—	—	—	25.00	13.00	9,900	790.0

**Table 4-23. ACTEK Metric Safety Hoist Rings**

Rated Loads (kg)	Thread Size (in.)	A	C	D	E	Standard U-Bar			Long U-Bar			G	H	Torque Kgm	Weight (kg)
						Part No.	B	F	Part No.	B	F				
400	M8 x 1.25	11	18	10	13	46912	32	68	—	—	—	47	25	0.86	0.17
500	M10 x 1.50	11	18	10	18	46916	30	68	—	—	—	47	25	1.5	0.17
1,050	M12 x 1.75	22	30	19	19	46924	60	121	47124	110	171	89	51	3.7	1.08
1,900	M16 x 2.00	22	30	19	29	46930	56	121	47130	106	171	89	51	8.4	1.12
2,150	M20 x 2.50	22	30	19	34	46936	52	121	47136	102	171	89	51	14	1.19
3,000	M20 x 2.50	36	43	25	32	46942	78	166	47142	118	206	131	76	14	3.03
4,200	M24 x 3.00	36	43	25	37	46948	74	166	47148	114	206	131	76	31	3.10
4,200	M30 x 3.50	36	43	25	58	—	—	—	46950	108	206	131	76	60	3.10
7,000	M30 x 3.50	45	54	32	42	46956	106	222	—	—	—	165	95	60	6.30
7,000	M30 x 3.50	45	54	32	62	46958	106	222	—	—	—	165	95	60	6.40
11,000	M36 x 4.00	57	71	44	64	46966	166	317	—	—	—	217	124	100	15.50
12,500	M42 x 4.50	57	71	44	82	46968	160	317	—	—	—	217	124	100	16.00
13,500	M48 x 5.00	57	71	44	82	46970	154	317	—	—	—	217	124	100	16.80
22,300	M64 x 6.00	76	103	57	101	46972	204	428	—	—	—	296	165	273	39.00
31,500	M72 x 6.00	95	133	70	132	46988	220	495	—	—	—	359	206	559	74.00
51,000	M90 x 6.00	102	153	83	177	46990	235	561	—	—	—	404	218	663	118.00

# FITTINGS & BLOCKS

Amick Associates, Inc.

## Forged Eye Bolts

version #2-04

the **Crosby** group  
inc.

Made in the U.S.A.

## Forged Eye Bolts

### Regular Nut



G-291 Regular Nut

### Shoulder Nut



G-277 Shoulder Nut

### Screw Eye Bolts



G-275 Screw Eye Bolt

4

Table 4-24. Regular Nut — Hot Dip Galvanized, Forged Steel

Shank Diameter and Length (in.)	Length of Thread (in.)	Eye Diameter		Working Load Limit (lbs.) <sup>①</sup>	Weight per 100 (lbs.)
		Inside Diameter (in.)	Outside Diameter (in.)		
1/4 x 2	1-1/2	1/2	1	500	6.00
1/4 x 4	2-1/2	1/2	1	500	13.50
5/16 x 2-1/4	1-1/2	5/8	1-1/4	800	18.75
5/16 x 4-1/4	2-1/2	5/8	1-1/4	800	25.00
3/8 x 2-1/2	1-1/2	3/4	1-1/2	1,200	24.33
3/8 x 4-1/2	2-1/2	3/4	1-1/2	1,200	37.50
3/8 x 6	2-1/2	3/4	1-1/2	1,200	43.75
1/2 x 3-1/4	1-1/2	1	2	2,200	50.00
1/2 x 6	3	1	2	2,200	62.50
1/2 x 8	3	1	2	2,200	75.00
1/2 x 10	3	1	2	2,200	88.00
1/2 x 12	3	1	2	2,200	100.00
5/8 x 4	2	1-1/4	2-1/2	3,500	101.25
5/8 x 6	3	1-1/4	2-1/2	3,500	120.00
5/8 x 8	3	1-1/4	2-1/2	3,500	131.00
5/8 x 10	3	1-1/4	2-1/2	3,500	162.50
5/8 x 12	4	1-1/4	2-1/2	3,500	175.00
3/4 x 4-1/2	2	1-1/2	3	5,200	185.90
3/4 x 6	3	1-1/2	3	5,200	180.00
3/4 x 8	3	1-1/2	3	5,200	200.00
3/4 x 10	3	1-1/2	3	5,200	237.50
3/4 x 12	4	1-1/2	3	5,200	251.94
3/4 x 15	5	1-1/2	3	5,200	300.00
7/8 x 5	2-1/2	1-3/4	3-1/2	7,200	275.00
7/8 x 8	4	1-3/4	3-1/2	7,200	325.00
7/8 x 12	4	1-3/4	3-1/2	7,200	400.00
1 x 6	3	2	4	10,000	425.00
1 x 9	4	2	4	10,000	452.00
1 x 12	4	2	4	10,000	550.00
1 x 18	7	2	4	10,000	650.00
1-1/4 x 8	4	2-1/2	5	15,200	750.00
1-1/4 x 12	4	2-1/2	5	15,200	900.00
1-1/4 x 20	6	2-1/2	5	15,200	1,150.00

① Ultimate Load is 5 x Working Load Limit.

Table 4-25. Shoulder Nut — Hot Dip Galvanized, Forged Steel

Shank Diameter and Length (in.)	Length of Thread (in.)	Eye Diameter		Working Load Limit (lbs.) <sup>①</sup>	Weight per 100 (lbs.)
		Inside Diameter (in.)	Outside Diameter (in.)		
1/4 x 2	1-1/2	1/2	7/8	500	6.61
1/4 x 4	2-1/2	1/2	7/8	500	8.61
5/16 x 2-1/4	1-1/2	5/8	1-1/8	800	12.50
5/16 x 4-1/4	2-1/2	5/8	1-1/8	800	18.75
3/8 x 2-1/2	1-1/2	3/4	1-3/8	1,200	19.00
3/8 x 4-1/2	2-1/2	3/4	1-3/8	1,200	31.58
1/2 x 3-1/4	1-1/2	1	1-3/4	2,200	37.50
1/2 x 6	3	1	1-3/4	2,200	56.25
5/8 x 4	2	1-1/4	2-1/4	3,500	75.00
5/8 x 6	3	1-1/4	2-1/4	3,500	100.25
3/4 x 4-1/2	2	1-1/2	2-3/4	5,200	125.00
3/4 x 6	3	1-1/2	2-3/4	5,200	150.00
7/8 x 5	2-1/2	1-3/4	3-1/4	7,200	225.00
1 x 6	3	2	3-3/4	10,000	375.00
1 x 9	4	2	3-3/4	10,000	429.00
1-1/4 x 8	4	2-1/2	4-1/2	15,200	650.00
1-1/4 x 12	4	2-1/2	4-1/2	15,200	775.00
1-1/2 x 15	6	3	5-1/2	21,400	1,425.00

① Ultimate Load is 5 x Working Load Limit.

**Note:** All bolts hot dip galvanized after threading. Hex nuts are American Standard Heavy, hot dip galvanized.

Table 4-26. Screw Eye Bolts — Hot Dip Galvanized, Forged Steel

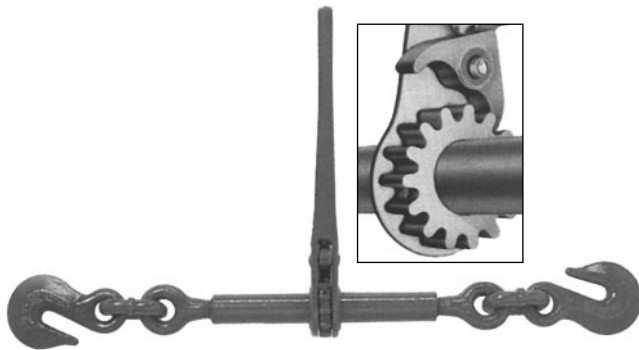
Shank Diameter and Length (in.)	Eye Diameter		Weight per 100 (lbs.)
	Shoulder		
	Inside Diameter (in.)	Outside Diameter (in.)	Shoulder
1/4 x 2	1/2	7/8	4.25
5/16 x 2-1/4	5/8	1-1/8	6.25
3/8 x 2-1/2	3/4	1-3/8	18.75
1/2 x 3-1/4	1	1-3/4	37.50
5/8 x 4	1-1/4	2-1/4	68.75

**Note:** All eye bolts are quenched and tempered except size 1/4" thru 3/8" are normalized.

## Load Binders

### L-140 Standard Ratchet Binder

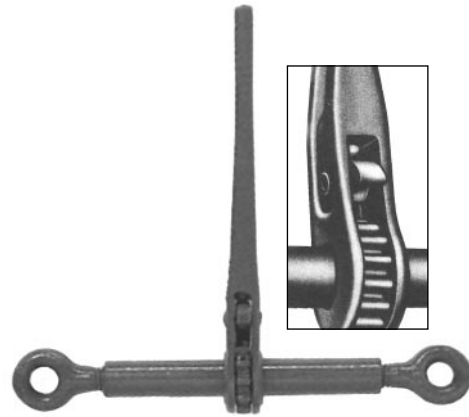
- Continuous take-up feature, infinite adjustment, gets the last half link of chain.
- One piece assembly, no bolts and nuts to loosen.
- Ratchet spring rust proofed.
- All load bearing or holding parts forged.
- Easy operating positive ratchet.



**L-140 Standard Ratchet Binder**

**Note:** Close up shows the heavy ratchet and pawl mechanism used to bind and release the load.

### L-140 Binder Less Links and Hooks



**L-140 Binder Less Links and Hooks**

**Note:** Close up shows the heavy ratchet and pawl mechanism used to bind and release the load.

**Table 4-27. L-140 Standard Ratchet Binder**

Catalog Number	Minimum – Maximum Chain Size (in.)	Handle Length (in.)	Barrel Length (in.)	Take-Up (in.)	Working Load Limit (lbs.)	Proof Load (lbs.)	Minimum Ultimate Strength (lbs.)	Weight (lbs.)
R-7	5/16 – 3/8	14	10	8	5,400	10,800	19,000	10.50
R-A	3/8 – 1/2	14	10	8	9,200	18,400	33,000	12.90
R-C	1/2 – 5/8	14	10	8	13,000	26,000	46,000	14.38

**Note:** Binders shown with Proof Load Pounds have been individually proof tested to these values shown prior to shipment.

**Table 4-28. L-140 Binder Less Links and Hooks**

Catalog Number	Maximum Chain Size (in.)	Handle Length (in.)	Barrel Length (in.)	Take-Up (in.)	Working Load Limit (lbs.)	Minimum Ultimate Strength (lbs.)	Weight (lbs.)
R-10	5/8	14	10	8	13,000	46,000	8.0

## Blocks

### Ordering Information

#### Blocks

The following information should be specified:

1. Stock number (if known).
2. Sheave size.
3. Block number (catalog number).
4. Number of sheaves.
5. Type of bearing: (BB) Bronze Bushed, (RB) Roller, (TB) Tapered Roller.
6. Type of hook or shackle.
7. Wire rope diameter.

All crane and some construction blocks are available as shown or with swivel shackle assembly, duplex swivel hook assembly or quadruple hook assembly. Various combinations of bearing assemblies can be furnished; such as bronze bushed sheaves and swivel hooks, roller or tapered roller bearing sheaves and hook assemblies or a combination of bronze, roller or tapered roller bearings.

#### Example:

18" 380 Series, Triple Sheave, Roller Bearing Crane Block with Roller Bearing Swivel.

Hook, 60 ton, light weight,  
1" wire rope diameter.

Model Number: M60T18L,  
Stock Number: 2012187

#### Sheaves

The following information should be specified:

1. Stock number (if known).
2. Sheave O.D.
3. Bearing type or plain bore.
4. Shaft or bore size.
5. Hub width.
6. Rim width.
7. Wire rope size.
8. Special machine features.
9. Special finishes.

Alemite lubrication through the hub of the sheaves can be installed on special order.

If hub or rim dimensions necessitate a dimension other than those shown, refer to Crosby Group Engineering Journal for minimums and maximums. Tapered roller bearing sheaves show width over bearing cones, which cannot be altered.

**Price and delivery for your special needs, if not shown, are available upon request.**

#### Please Contact:

Amick Associates, Inc.  
11 Sycamore Street  
Carnegie, PA 15106  
Phone: (412) 429-1212  
(800) 445-9456  
Fax: (412) 429-0191



Made in the U.S.A.

## McKissick® Utility Crane Blocks — 380 Series Hook Blocks

- Wide range of products available.
  - Capacity: 5 to 300 tons — larger models available.
  - Sheave sizes: 10" to 30".
  - Wire line sizes: 7/16" to 1-1/4".
- Manufactured by an ISO 9001 and API Q1 certified facility.
- All single point shank hooks are genuine Crosby®, forged alloy steel, quenched and tempered, and have the patented QUIC-CHECK® markings. (Duplex hooks are available on most sizes.)
- All 380 blocks are furnished standard with roller bearings.
- Reeving guides standard — all models.
- Blocks through 25 tons use 319N style hooks with S-4320 latches.
- Sheave lubrication through center pin — separate lube channel to each bearing.
- Sheaves fully protected by side plates.
- Dual action hook (swings and rotates).
- Repair parts available through worldwide distribution network.
- Design Factor of 4 to 1 (unless otherwise noted).
- All 380 blocks, 16" and larger, are furnished with McKissick® Roll-Forged™ sheaves with flame hardened grooves.
- Look for the orange hook...the mark of genuine McKissick quality.

### Options Available

- Bronze bushed sheaves.
- Duplex hooks.
- Swivel tee and shackle assemblies.
- Sheave shrouds.
- Anti-rotation — locking device (75 tons and larger).
- Plate steel cheek weights.
- Third party testing with certification available upon request.



380 Series Hook Block

4

**Table 4-29. Dead End Chart (Double, Triple & Quad Sheave Blocks)**

Wire Rope Size (in.)	Dimensions (in.)		Recommended Wedge Socket	
	T Thickness	U Hole Diameter	McKissick US-422 / US-422T Utility Socket	
			Stock No.	Size
7/16	1.00	1.28	1044309 ①	US4 7/16
1/2	1.00	1.28	1044318 ①	US4 1/2
9/16	1.00	1.28	1044336 ①	US5 9/16
5/8	1.00	1.28	1044345 ①	US5 5/8
3/4	1.25	1.66	1044363 ①	US6 3/4
7/8	1.25	1.66	1038580	US7 7/8
1	1.25	1.66	1038607	US8 1
1-1/8	1.75	2.56	1038616	US10 1-1/8
1-1/4	1.75	2.56	1038625	US10 1-1/4

① US-422T TERMINATOR style.

# FITTINGS & BLOCKS

Amick Associates, Inc.

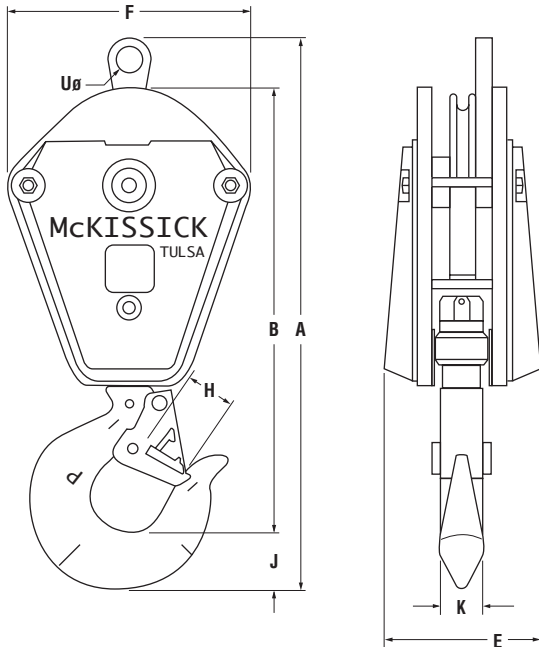
## Blocks

version #2-04

the **Grosby** group  
inc.

Made in the U.S.A. 

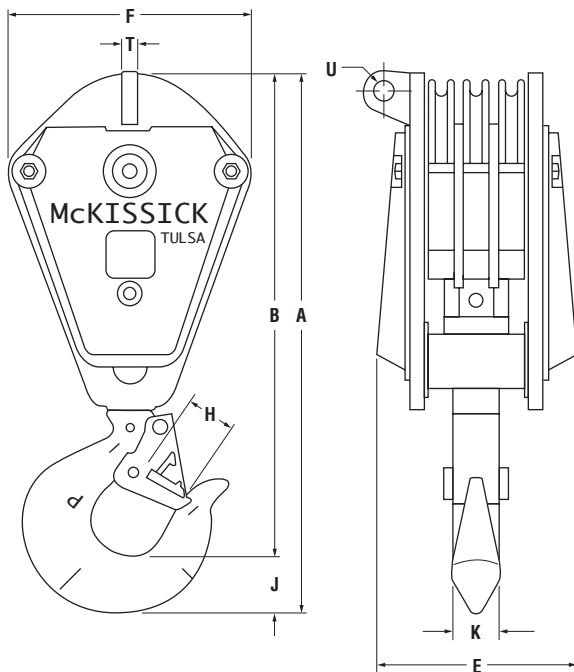
4



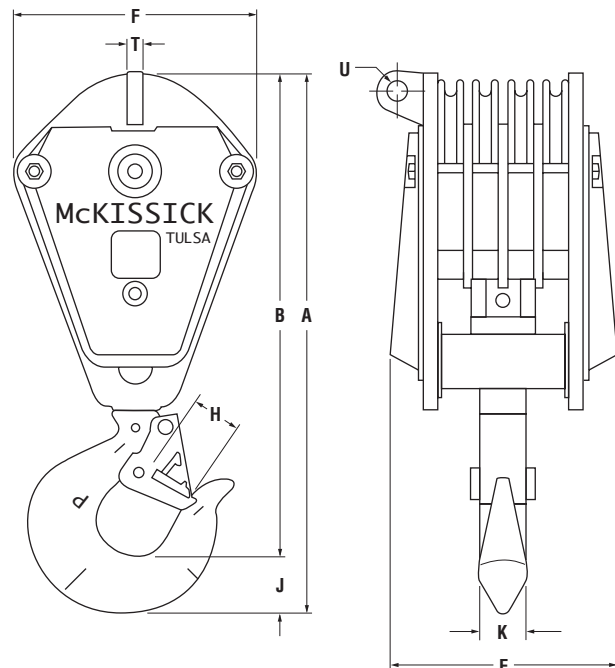
McKissick® Utility Crane Block — 381 — Single



McKissick Utility Crane Block — 382 — Double



McKissick Utility Crane Block — 383 — Triple



McKissick Utility Crane Block — 384 — Quad

**Note:** Thickness (E) shown is for blocks containing cheek weights (Light Medium — LM, Medium — M and Heavy — H). The thickness (E) for non-weighted blocks (Light — L) is measured over side plates.



Made in the U.S.A.

## McKissick® Utility Crane Blocks — 380 Series Easy Reeve® Hook Blocks

- Wide range of products available.
  - Capacity: 5 to 80 tons — larger models available.
  - Sheave sizes: 10" to 20".
  - Wire line sizes: 7/16" 1-1/4".
- Manufactured by an ISO 9001 and API Q1 certified facility.
- All single point shank hooks are genuine Crosby®, forged alloy steel, quenched and tempered, and have the patented QUIC-CHECK® markings. (Duplex hooks are available on most sizes.)
- All Easy Reeve® Blocks are furnished standard with Roller Bearings.
- Reeving guides standard — all models.
- Blocks through 20 tons use 319N hooks with S-4320 latches.
- Heavy Duty Positive Locking (PL) Latch — Models: 25 tons and larger.
- Sheave lubrication through center pin — separate lube channel to each bearing.
- Sheaves fully protected by side plates.
- Dual action hook (swings and rotates).
- Repair parts available through worldwide distribution network.
- Design Factor of 4 to 1 (unless otherwise noted).
- All Easy Reeve blocks, 16" and larger, are furnished with McKissick® Roll-Forged™ sheaves with flame hardened grooves.
- Look for the orange hook...the mark of genuine McKissick quality.

### Options Available

- Duplex hooks (75 tons and larger).
- Swivel tee and shackle assemblies.
- Sheave shrouds.
- Anti-rotation — locking device (75 tons and larger).
- Plate steel cheek weights.
- Third party testing with certification available upon request.

**Table 4-30. Dead End Chart (Double, Triple & Quad Sheave Blocks)**

Wire Rope Size (in.)	Dimensions (in.)		Recommended Wedge Socket	
	T Thickness	U Hole Diameter	McKissick US-422 / US-422T Utility Socket	
			Stock No.	Size
7/16	1.00	1.28	1044309 ①	US4 7/16
1/2	1.00	1.28	1044318 ①	US4 1/2
9/16	1.00	1.28	1044336 ①	US5 9/16
5/8	1.00	1.28	1044345 ①	US5 5/8
3/4	1.25	1.66	1044363 ①	US6 3/4
7/8	1.25	1.66	1038580	US7 7/8
1	1.25	1.66	1038607	US8 1
1-1/8	1.75	2.56	1038616	US10 1-1/8
1-1/4	1.75	2.56	1038625	US10 1-1/4

① US-422T TERMINATOR style.



**380 Series Easy Reeve Crane Block**

# FITTINGS & BLOCKS

Amick Associates, Inc.

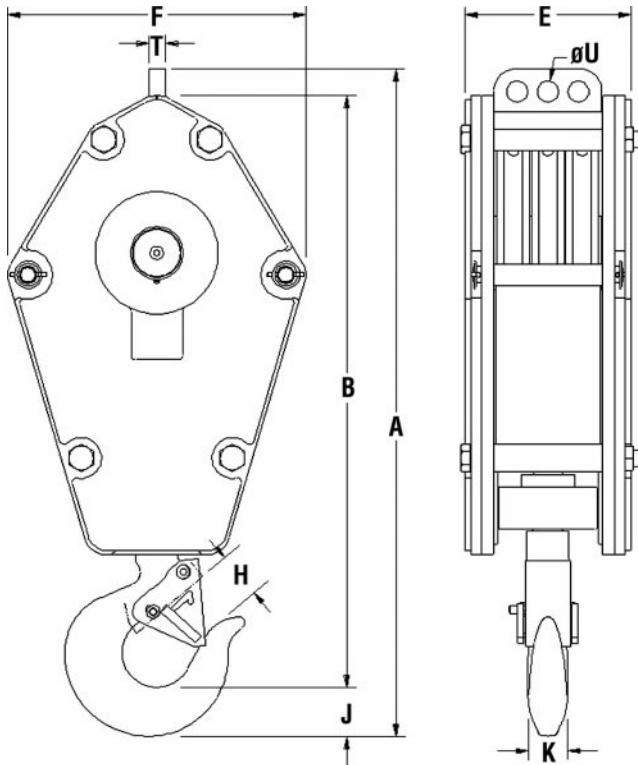
Blocks

version #2-04

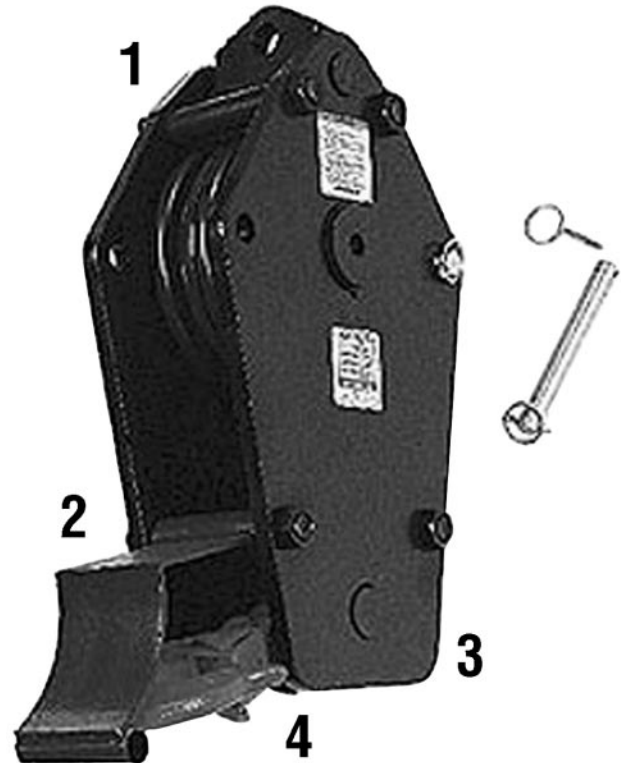
the **Crosby** group  
inc.

Made in the U.S.A. 

4



McKissick® 380 Series Easy Reeve® Crane Block Dimensions

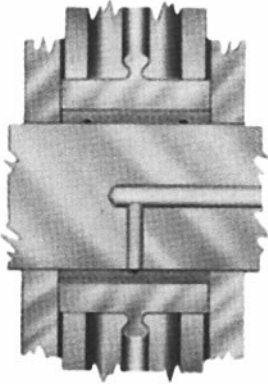


McKissick® 380 Series Easy Reeve® Crane Block

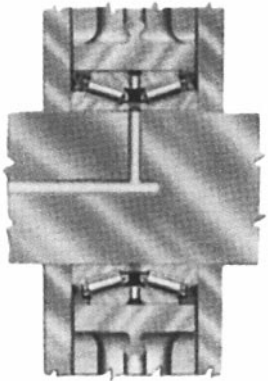
1. **Center "Dead End"** to promote better block travel under various reeving.
2. **Sheave Guards** that open to allow block reeving without removing the rope end fitting.
3. **Flat Bottom** side plate for self standing during reeving process.
4. **Forged Crosby® alloy steel hooks** with patented QUIC-CHECK® markings and heavy duty positive locking hook latch.

## Construction and Crane Blocks — Important Considerations in Block Requirements

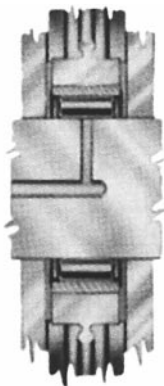
### Available Bearing Types



**Bronze Bushed —**  
S.A.E. 660 Bronze with Figure "8" Oil Groove



**Double Row Sealed Tapered Roller Bearing**



**Straight Roller Bearing**

### The Sheave

- Note the groove form with proper line support and gently rounded lips to prevent line chafing when fleet angles etc. are present.
- The groove is completely machined to proper line size.
- Note the dense martensitic structure clearly outlined by the etch. This flame-hardened surface in the wear area of the sheave always presents a smooth, uncorrugated, proper size groove face to the line. Sheaves 14" (356 mm) diameter and over flame hardened in groove to minimum 35 Rockwell "C." Smaller sheaves can be flame hardened on special order.



**Sheave Section Cut**

**Note:** Unretouched photograph of a section cut from a flame-hardened McKissick® sheave (etched 2-1/2 minutes) (NH<sub>4</sub>)<sub>2</sub>S<sub>4</sub>O<sub>8</sub>.

### Available Connections

All Crane and Construction Blocks can be furnished with:



**Swivel Shackle, in Selected Capacities, with Bronze Thrust or Roller Thrust Bearing**



**Single Hook in Capacities to 300 Tonnes**



**Duplex Swivel Hook in Standard Capacities to 1,000 Tonnes, Larger Sizes Available**



**Quad Swivel Hook from 200 Tonnes and Larger**

# FITTINGS & BLOCKS

Amick Associates, Inc.

## Blocks

version #2-04

the **Grosby** group  
inc.

Made in the U.S.A. 

### Snatch Blocks

#### New Improved Light Champion

- Forged alloy heat treated hooks.
- Forged steel swivel tees, yokes and shackles.
- Hook and shackle assemblies quickly interchangeable.
- Can be furnished with bronze bushings or roller bearings.
- Opening feature permits insertion of rope while block is suspended from gin-pole.
- Available with hook latch.
- Pressure lube fittings.
- 3" through 18" 418 and 419 blocks have exclusive bolt-retaining spring to assure no lost bolts.
- Patented in U.S.A.



**418**  
with Hook



**419**  
with Shackle



**404**  
Toggle Block  
(Tail Board)

### Interchangeable Fittings



Step 1



Step 2



Step 3



Step 4

Table 4-31. Snatch Blocks

Sheave Size (in.)	Center Pin Diameter (in.)	Standard Wire Rope Size (in.) <sup>①</sup>	Weight (lbs.)			Working Load Limit (tons) <sup>②</sup>
			418	419	404	
3 <sup>③</sup>	3/4	3/8	3	3 <sup>④</sup>	3	2
4-1/2 <sup>③</sup>	1	1/2	11	12	6	4
6	1-1/2	3/4	26	27	15	8
8	1-1/2	3/4	33	34	21	8
10	1-1/2	3/4	41	42	29	8
12	1-1/2	3/4	48	49	36	8
14	1-1/2	3/4	55	56	—	8
16	2-1/2	7/8	130	135	—	12
18	2-3/4	1	150	155	—	15

① May be furnished in other wire rope sizes.

② Ultimate Load is 4 x Working Load Limit.

③ Available in Bronze Bushed only. 3" and 4-1/2" have self-lubricating Bronze Bushing.

④ Fitted with 1-1/4" I.D. Swivel Eye.

**Note:** In ordering, please specify: Size, Block Number, Hook or Shackle, Bronze Bushed or Roller Bearing and Wire Rope Size.



Made in the U.S.A.

## McKissick® Snatch Blocks — 430, 431 and 407

### Super Champion

- Drop forged, heat treated swivel hook or swivel shackle.
- Hook and shackle assemblies on 8" through 14" sizes can be interchanged.
- Can be furnished with bronze bushings or roller bearings.
- Pressure lube fittings.
- 8" through 14" 430 and 431 blocks have exclusive bolt retaining spring to assure no lost bolts.
- Can be furnished with SS-4055 hook latch.
- Fatigue rated.
- 8" and 10" models furnished with dual rated wireline sheaves.



430  
with Hook



431  
with Shackle



407  
Tail Board

Table 4-32. McKissick Snatch Blocks

Sheave Diameter (in.)	Bearing Code	Stock No.			Wire Rope Size (in.)	Working Load Limit (tons) ①	Weight Each (lbs.)			Replacement Sheave Stock No.
		430 with Hook	431 with Shackle	407 Tail Board			430 with Hook	431 with Shackle	407 Tail Board	
8	BB	120023	121022	103523	1 - 1-1/8	20	75	87	42	461440
	RB	120041	121040	103541	1 - 1-1/8	20	75	87	42	473614
	BB	120096	121095	103603	1 - 1-1/8	20	89	101	55	462083
10	RB	120112	121111	103621	1 - 1-1/8	20	89	101	55	474105
	BB	208536	169917	184375	1	20	103	115	70	462680
	RB	208554	209303	184393	1	20	103	115	70	474524
12	BB	120176	121175	103685	1-1/8	20	103	115	70	462699
	RB	120194	121193	103701	1-1/8	20	103	115	70	474533
	BB	208572	209321	184419	1	20	123	135	90	463457
14	RB	208590	170424	184437	1	20	123	135	90	475024
	BB	120256	121255	103765	1-1/8	20	123	135	90	463466
	RB	120274	121273	103783	1-1/8	20	123	135	90	475033
18	BB	208689	209410	184552	1	25	240	260	165	4100298
	RB	208732	209465	184605	1	25	240	260	165	4200331
	BB	119482	119561	119641	1-1/8	25	240	260	165	4103348
20	RB	119491	119570	119650	1-1/8	25	240	260	165	4200322
	BB	208750	209483	184623	1-1/8	30	375	400	215	4103936
	RB	208787	169864	184650	1-1/8	30	375	400	215	4200769
24	BB	119507	119589	119669	1-1/4	30	375	400	215	4103945
	RB	119516	119598	119678	1-1/4	30	375	400	215	4200778
	BB	208812	209526	184687	1-1/8	30	450	475	290	4104114
24	RB	208858	209553	184721	1-1/8	30	450	475	290	4200983
	BB	119525	119605	119687	1-1/4	30	450	475	290	4104123
	RB	119534	119614	119696	1-1/4	30	450	475	290	4200992

① Ultimate Load is 4 times the Working Load Limit.

Note: May be furnished in other wire rope sizes.

# FITTINGS & BLOCKS

Amick Associates, Inc.

## Sheaves

version #2-04

the **Grosby** group  
inc.

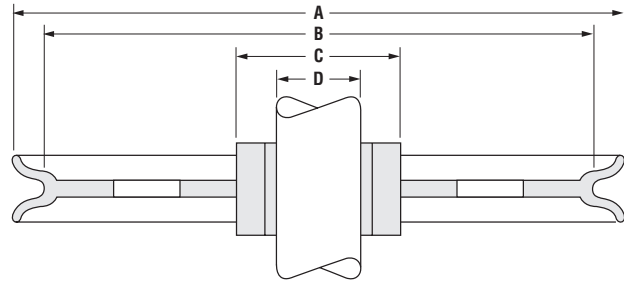
Made in the U.S.A. 

## Sheaves

### McKissick® Sheaves

#### Bronze Bushed Sheaves

- McKissick Bronze Bushed Sheaves are equipped with S.A.E. 660 Bronze Bushings for cold finished shafts with oil groove. For sizes not listed, McKissick Finished Bore Sheaves can be equipped with bronze bushings at an optional charge.
- Roll Forged™ sheaves are available in sizes up to 72" in diameter.



McKissick Bronze Bushed Sheaves

Table 4-33. McKissick Bronze Bushed Sheaves

"A" Nominal Outside Diameter (in.)	Stock No.	Pattern Number	Wire Line Size (in.)	"D" Shaft Size (in.)	Hub Width (in.)	Rim Width (in.)	"C" Nominal Hub Outside Diameter (in.)	"B" Nominal Tread Diameter (in.)	Material	Approximate Weight (lbs.)
2-1/4	907004	1173	1/4	3/8	5/8	9/16	3/4	1-7/8	B.S.	.75
3	907059	1173	3/16	3/8	25/32	3/4	1	2-3/8	P.M.	1.00
3	907077	1173	3/16	1/2	25/32	3/4	1	2-3/8	P.M.	1.00
3	907095	1173	3/16	5/8	25/32	3/4	1	2-3/8	P.M.	1.00
3	907022	1173	1/4	3/8	1/2	1/2	1	2-5/8	P.M.	.75
3	907040	1173	1/4	1/2	1/2	1/2	1	2-5/8	P.M.	.75
3	460165	3X	1/4	1/2	1-5/16	1-1/4	1-1/8	2-1/16	B.S.	1.00
3	460110	3-1	5/16	3/4	1	7/8	1-3/4	2-1/4	P.M.	1.50
3	907068	1173	3/8	3/8	3/4	3/4	1	2-3/8	P.M.	1.00
3	916101	1208	3/8	3/8	25/32	3/4	1-1/2	2-3/8	B.S.	1.00
3	907086	1173	3/8	1/2	3/4	3/4	1	2-3/8	P.M.	1.00
3	916110	1208	3/8	1/2	25/32	3/4	1-1/2	2-3/8	B.S.	1.00
3	460156	3X	3/8	1/2	1-5/16	1-1/4	1-1/8	2-1/16	B.S.	1.00
3	907102	1173	3/8	5/8	3/4	3/4	1	2-3/8	P.M.	1.00
3	460147	3-1	3/8	3/4	1	7/8	1-3/4	2-1/4	P.M.	1.50
3	460129	3-1	7/16	3/4	1	7/8	1-3/4	2-1/4	P.M.	1.50
3	916129	1208	1/2	3/8	1-1/4	1-1/8	1-7/8	2	B.S.	1.33
3	916138	1208	1/2	1/2	1-1/4	1-1/8	1-7/8	2	B.S.	1.50
4	460290	4-1	1/8	1	1	7/8	2	3-1/8	B.S.	2.00
4	907111	1173	3/16	1/2	3/4	5/8	1-3/8	3-1/2	P.M.	1.00
4	907139	1173	3/16	5/8	3/4	5/8	1-3/8	3-1/2	P.M.	1.00
4	916147	1208	1/4	1/2	13/16	3/4	2	3-1/4	B.S.	1.50
4	916165	1208	1/4	3/4	13/16	3/4	2	3-1/4	B.S.	1.50
4	460307	4-1	1/4	1	1	7/8	2	3-1/8	B.S.	2.00
4	907120	1173	5/16	1/2	3/4	5/8	1-3/8	3-1/2	P.M.	1.00
4	907148	1173	5/16	5/8	3/4	5/8	1-3/8	3-1/2	P.M.	1.00
4	907166	1173	3/8	1/2	13/16	3/4	1-1/2	3-1/4	P.M.	1.25
4	916156	1208	3/8	1/2	13/16	3/4	2	3-1/4	B.S.	1.50
4	907184	1173	3/8	5/8	13/16	3/4	1-1/2	3-1/4	P.M.	1.40
4	907200	1173	3/8	3/4	13/16	3/4	1-1/2	3-1/4	P.M.	1.25
4	460316	4-1	3/8	1	1	7/8	2	3-1/8	B.S.	2.00
4	907228	1173	1/2	1/2	1-1/16	1	1-5/8	3-3/16	P.M.	1.50
4	916192	1208	1/2	1/2	1-1/8	1	1-5/8	3-3/16	B.S.	2.00
4	907246	1173	1/2	5/8	1-1/16	1	1-5/8	3-3/16	P.M.	1.50
4	907264	1173	1/2	3/4	1-1/16	1	1-5/8	3-3/16	P.M.	1.50
4	916174	1208	3/8	3/4	13/16	3/4	2	3-1/4	B.S.	1.50
4	460414	4-K	3/8	1	1-1/2	1-3/8	2	3	F.S.	3.50
4	460405	4-K	1/2	1	1-1/2	1-3/8	2	3	F.S.	3.50
4	460423	4-K	5/8	1	1-1/2	1-3/8	2	3	F.S.	3.50
4-1/4	460450	4E	3/8	5/8	1-3/16	15/16	2-1/8	3-3/8	B.S.	2.40
4-1/4	460441	4E	1/2	5/8	1-3/16	15/16	2-1/8	3-3/8	B.S.	2.40

Note: Roller and tapered bearings available.

Note: Other sheave sizes available.

Table 3-33. (Continued) McKissick Bronze Bushed Sheaves

"A" Nominal Outside Diameter (in.)	Stock No.	Pattern Number	Wire Line Size (in.)	"D" Shaft Size (in.)	Hub Width (in.)	Rim Width (in.)	"C" Nominal Hub Outside Diameter (in.)	"B" Nominal Tread Diameter (in.)	Material	Approximate Weight (lbs.)
12	908147	1173	3/4	1-1/8	1-5/8	1-1/2	2-3/4	10-1/4	C.I.	18.25
12	914121	1193	3/4	1-1/8	1-5/8	1-1/2	5-1/4	10-1/4	C.I.	25.50
12	914149	1193	3/4	1-1/4	1-5/8	1-1/2	5-1/4	10-1/4	C.I.	25.50
12	914167	1193	3/4	1-1/2	1-5/8	1-1/2	5-1/4	10-1/4	C.I.	25.50
12	346593	12-2-A	3/4	2-1/4	2-5/16	2-3/16	4-1/2	9-3/4	R.F.	26.00
12	4104882	12-9	3/4	2-1/2	1-3/4	1-5/8	4-1/2	9-3/4	R.F.	25.00
12	462449	12-2-A	3/4	2	2-5/16	2-3/16	4-1/2	9-3/4	R.F.	26.00
12	4104917	12-2-A	3/4	2-1/2	2-5/16	2-3/16	4-1/2	9-3/4	R.F.	25.00
12	462485	12-5	3/4	3	3	1-7/8	5-1/2	9-3/8	R.F.	21.00
12	908227	1173	7/8	1-1/4	2	1-3/4	3-3/4	10	C.I.	20.25
12	908245	1173	7/8	1-1/2	2	1-3/4	3-3/4	10	C.I.	20.25
12	462458	12-2-A	7/8	2	2-5/16	2-3/16	4-1/2	10-1/4	R.F.	26.00
12	462671	12-NS-3	7/8	2-1/4	2-1/2	2-3/8	4-1/2	9-3/8	R.F.	28.00
12	4104891	12-9	7/8	2-1/2	1-3/4	1-5/8	4-1/2	10-1/4	R.F.	25.00
12	462467	12-2-A	1	2	2-5/16	2-3/16	4	10	R.F.	26.00
12	462699	12-NS-3	1-1/8	2-1/4	2-1/2	2-3/8	4-1/2	9-3/8	R.F.	26.00
13	462779	13-2	3/8	2	1-1/2	1-1/8	3-1/2	11-5/8	R.F.	14.00
13	462788	13-2	1/2	2	1-1/2	1-1/8	3-1/2	11-5/8	R.F.	14.00
14	463625	14-1	5/8	1-1/2	1-3/4	1-5/8	3-1/4	12-1/8	R.F.	20.00
14	463634	14-1	3/4	1-1/2	1-3/4	1-5/8	3-1/4	11-3/8	R.F.	20.00
14	463643	14-1	7/8	1-1/2	1-3/4	1-5/8	3-1/4	11-3/8	R.F.	20.00
14	463448	14NS-3	7/8	2-1/4	2-1/2	2-3/8	4-1/2	12-1/4	R.F.	28.00
14	463457	14NS-3	1	2-1/4	2-1/2	2-3/8	4-1/2	11-3/8	R.F.	28.00
14	463466	14NS-3	1-1/8	2-1/4	2-1/2	2-3/8	4-1/2	11-3/8	R.F.	28.00
14	463518	14WL-8	1/2	3-3/4	2-1/2	1-3/8	5-1/16	12-5/8	D.I.	15.00
14	4103552	14-2	5/8	2	1-1/4	1-5/8	4-1/2	12-1/8	R.F.	29.20
14	908281	1173	3/4	1-1/8	1-5/8	1-1/2	3-1/4	12-1/4	C.I.	26.50
14	908307	1173	3/4	1-1/4	1-5/8	1-1/2	3-1/4	12-1/4	C.I.	26.50
14	917173	1208	3/4	1-1/4	1-5/8	1-1/2	4	12	R.F.	26.50
14	917191	1208	3/4	1-1/2	1-5/8	1-1/2	3-1/2	11-3/4	R.F.	26.50
14	4103632	14-2	3/4	2	1-3/4	1-5/8	4-1/2	11-3/4	R.F.	30.00
14	4104828	24S7-A	3/4	2-3/4	2-5/16	2-3/16	5-1/2	11-3/4	R.F.	35.00
14	914443	1193	7/8	1-1/4	1-5/8	1-1/2	3-1/2	12-1/8	C.I.	34.00
14	917182	1208	7/8	1-1/4	1-5/8	1-1/2	4	12	R.F.	26.50
14	914452	1193	7/8	1-1/2	1-5/8	1-1/2	3-1/2	12-1/8	C.I.	34.00
14	917208	1208	7/8	1-1/2	1-5/8	1-1/2	4	12	R.F.	26.50
14	463484	14PL-8	7/8	2	2-5/16	2-1/8	4-1/2	11-3/8	R.F.	28.00
14	4103641	14-2	7/8	2	1-3/4	1-5/8	4-1/2	12-1/4	R.F.	31.00
16	4101395	16-4	1/2	3-1/2	2-3/4	2-1/2	5-3/4	14-1/4	R.F.	54.00
16	4100047	16-4	3/4	3-1/2	2-3/4	2-1/2	5-3/4	13-3/8	R.F.	47.00
16	4100109	16-17	3/4	3-3/4	2-3/4	2-1/2	5-3/4	13-3/8	R.F.	42.00
16	4103703	16-5	7/8	2-1/2	2-5/16	2-3/16	4-1/2	12-15/16	R.F.	35.00
16	4105211	16-5	7/8	2-3/4	2-5/16	2-3/16	4-1/2	12-15/16	R.F.	42.00
16	917342	1208	1	1-1/2	2	1-3/4	4-1/4	13-1/4	R.F.	34.00
16	917360	1208	1	2	2	1-3/4	4-1/4	13-1/4	R.F.	34.00
16	4100127	16-17	1	3-3/4	2-3/4	2-1/2	5-3/4	13-1/4	R.F.	42.00
18	4105131	18-2	7/8	3	2-5/16	2-3/16	5-1/2	14-15/16	R.F.	52.00
18	4105195	26FS-8	7/8	5-1/2	2-7/8	2-5/8	8	14-15/16	R.F.	59.00
18	917468	1208	1	1-1/2	2	1-3/4	3-1/4	14-7/8	R.F.	55.00
18	917486	1208	1	2	2	1-3/4	4-1/2	14-7/8	R.F.	55.00
18	914826	1193	1	2	2	1-3/4	5-3/4	15-3/4	R.F.	62.00
18	4104052	18-2	1	2-3/4	2-5/16	2-3/16	5-1/2	14-7/8	R.F.	66.00
18	4105140	18-2	1	3	2-5/16	2-3/16	5-1/2	14-7/8	R.F.	52.00
18	4100298	26FS-7	1	4	3	2-3/4	6-1/2	15-1/8	R.F.	81.00

**Note:** Roller and tapered bearings available.**Note:** Other sheave sizes available.

# FITTINGS & BLOCKS

Amick Associates, Inc.

## Sheaves

version #2-04



Made in the U.S.A. 

**Table 3-33. (Continued) McKissick Bronze Bushed Sheaves**

"A" Nominal Outside Diameter (in.)	Stock No.	Pattern Number	Wire Line Size (in.)	"D" Shaft Size (in.)	Hub Width (in.)	Rim Width (in.)	"C" Nominal Hub Outside Diameter (in.)	"B" Nominal Tread Diameter (in.)	Material	Approximate Weight (lbs.)
18	4103348	26FS-7	1-1/8	4	3	2-3/4	6-1/2	15-1/8	R.F.	60.00
20	4100341	20-2	3/4	3	2-5/16	2-3/16	5-1/2	18	R.F.	68.00
20	4105239	20-2	3/4	3-3/4	2-3/4	2-1/8	6-1/2	18	R.F.	68.00
20	4100350	20-2	7/8	3	2-5/16	2-3/16	5-1/2	17-1/8	R.F.	45.00
20	4105266	32-T-8	7/8	5-1/2	2-7/8	2-5/8	8	16-15/16	R.F.	68.00
20	4100369	20-2	1	3	2-5/8	2-3/16	5-1/2	17-1/8	R.F.	80.15
20	4105328	20-2	1	3-1/4	2-5/16	2-3/16	5-1/2	17-1/8	R.F.	68.00
20	4105257	20-2	1	3-3/4	2-3/4	2-1/8	6-1/2	16-1/2	R.F.	68.00
20	4105275	32-T-8	1	5-1/2	2-7/8	2-5/8	8	17-1/8	R.F.	68.00
24	4105346	24TS-8	9/16	5-3/4	3-3/8	3-1/8	8	22	R.F.	113.00

**Note:** Roller and tapered bearings available.

**Note:** Other sheave sizes available.

# STEEL MESH SLINGS

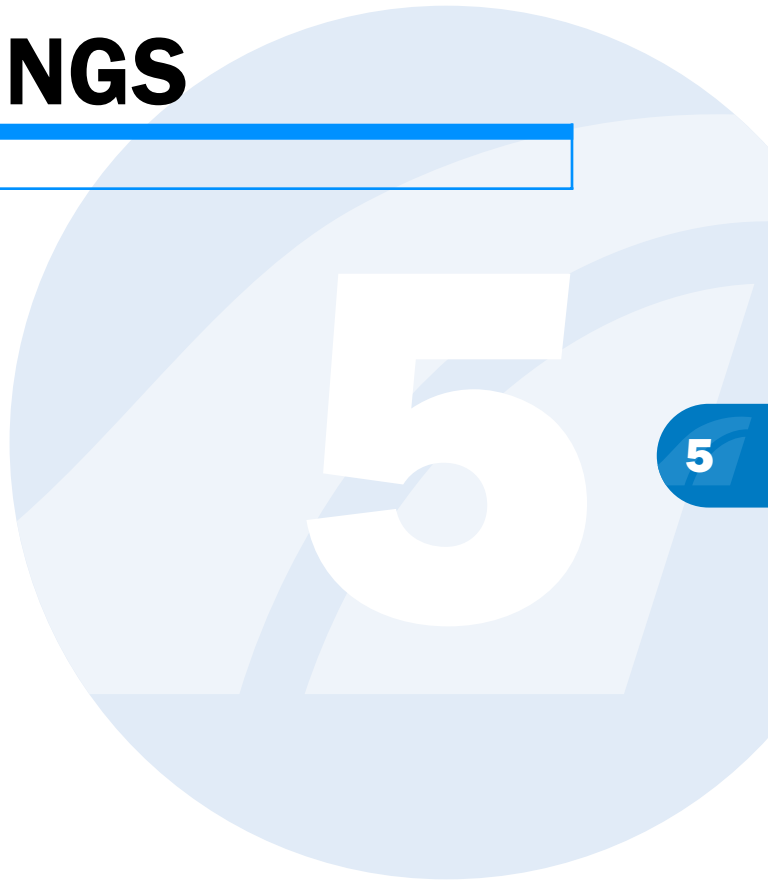
---

## Introduction

Mesh & Fittings —  
Highest Standard Strength at Competitive Prices

## Technical Data

How to Select the Proper Specification  
How to Select Sling Width  
How to Select Overall Sling Length



## Introduction

### Introduction



5

Get a firm, gentle grip on the materials you're handling with wire mesh slings. With this unique materials handling tool, you can put a move on just about anything — whatever the shape, size or weight. Its flexible, woven-wire fabric conforms even to irregular shapes, for a non-slip grip. It's strong enough to carry anything you can wrap it around. It greatly reduces load damage during shipping and handling. And because it's simple to rig in either choke or basket hitch, it greatly reduces rigging and unhitching time and eliminates the need for a two-legged sling.

The wire mesh sling is made by interweaving smooth, spiral wires. This gives the sling complete flexibility. It will conform to the contours of your load, eliminating the danger of gouging, marring, crushing or cutting load members. For handling particularly delicate materials, such as those with turned or ground surfaces, slings covered with PVC or neoprene are available.

The wide bearing surface of this sling will give you better load balance and gripping power. It grips instantly when load is applied, so there's no slipping or shifting. It's made of metal, with no core to rot, no chance of sudden failure. The wire mesh sling will not whip, kink or tangle, and there are no loose ends to snag your load or operator.

### Mesh & Fittings — Highest Standard Strength at Competitive Prices

#### Reprint of OSHA Sling Regulations for Wire Mesh Slings\*

The following requirements apply specifically to the wire mesh slings:

1. Each sling must carry a durable marking showing choke and basket hitch rated capacities.
2. All new and repaired slings must be proof tested at a minimum of 1-1/2 times rated capacity before putting into service, and the end fittings exhibit no deformation after proof testing.
3. Slings of the type shown in OSHA table N-184-15 must not be used with loads in excess of the rated capacities shown in this table. Slings not included in the table shall be used only in accordance with the manufacturer's recommendations.
4. Only slings constructed in the following manner shall be used:
  - a. End fittings must be at least as strong as the mesh.
  - b. The mesh and end fittings must be joined so that the rated capacity of the sling is not reduced, the load is evenly distributed across the mesh width, and sharp edges of the fitting will not damage the mesh.
  - c. If elastomer coated, the coating must not diminish the rated capacity of the sling and the sling must be proof tested before it is coated.
5. Slings not impregnated with elastomers may be used in a temperature range of -20°F to +550°F without decreasing this rated capacity. Slings impregnated with neoprene or PVC may be used only in a temperature range of 0°F to +200°F. The sling manufacturer's recommendation must be followed for operations outside these temperature ranges or for slings impregnated with other materials.
6. Slings must not be used unless they were repaired by a wire mesh manufacturer (or an equivalent entity). Once a sling is repaired, the nature of the repair, and the entity making the repairs must be permanently marked or tagged on the sling or else a written record maintained to indicate this information.
7. Slings must be immediately removed from service if any of the following conditions are present:
  - a. a broken weld or brazed joint
  - b. reduction in wire diameter of
    1. 25% due to abrasion
    2. 15% due to corrosion
  - c. lack of flexibility due to distortion of the fabric.
  - d. distortion of the choker fitting so that the depth of the slot is increased more than 10%.
  - e. distortion of the end fitting so that the width of the crane hook opening is decreased more than 10%.
  - f. a 15% reduction of the original cross sectional area of metal at any point around the crane hook.
  - g. distortion of either end fitting out of its plane.

#### Care & Maintenance Recommendations

Before using a sling, make sure it contains the proper type of mesh for the application intended. When using a choke hitch, be positive the center of gravity of the load falls within the width of the mesh. Edges of loads should be kept away from the end fittings and the mesh adjacent to the fitting to avoid distortion of the sling. When a load is lifted with a pair of slings, they should be attached to a spreader beam.

**Call us for repairs.**

#### \*WARNING

Do not exceed rated capacities. Do not Side Load or Twist Slings. 90° lifting only.

## Technical Data

### How to Select the Proper Specification

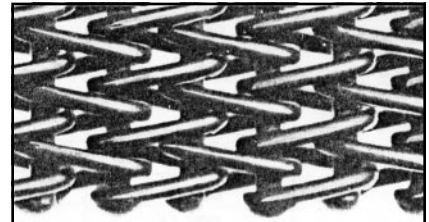
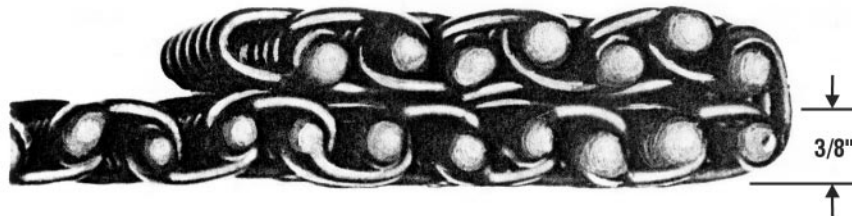
#### 10-Gauge Heavy Duty

Offers longest service life and is the most resistant to rough treatment. Excellent for abrasive loads, cutting action of sharp-edged loads, off-center lifts.



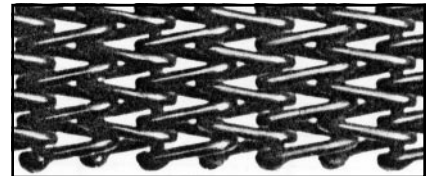
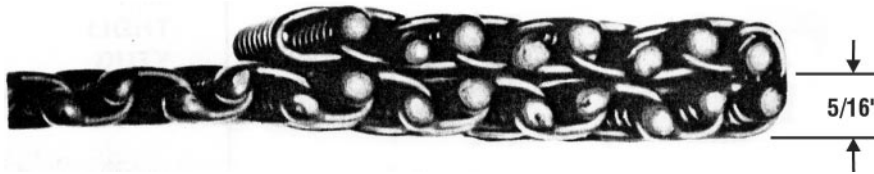
#### 12-Gauge Medium Duty

Recommended for most applications. Combines good service life with good sling flexibility, resistance to abrasion and cutting for long life and easiest handling in most applications.



#### 14-Gauge Light Duty

Recommended where maximum flexibility and minimum load damage are the two most important considerations.



**Amick Associates, Inc. makes 2-inch to 12-inch wide wire mesh slings according to customer's specifications.**

**Amick Associates also has the ability to repair all your existing wire mesh slings.**

# STEEL MESH SLINGS

Amick Associates, Inc.

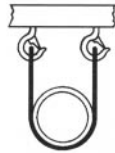
## Technical Data

version #2-04

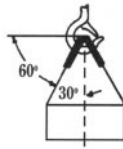
### How to Select Sling Width



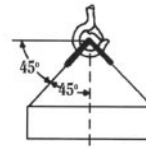
Choker



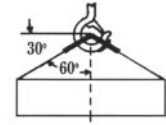
Vertical Basket



30° Vert. / 60° Horiz.



45° Vert. / 45° Horiz.



60° Vert. / 30° Horiz.

Table 5-1. 10-Gauge Heavy Duty Steel Mesh Sling\*

Nominal Width of Sling (in.)	Choker	Vertical Basket	30° Vertical 60° Horizontal	45° Vertical 45° Horizontal	60° Vertical 30° Horizontal
2	1,600	3,200	2,700	2,000	1,600
3	3,000	6,000	5,100	3,800	2,800
4	4,400	8,800	7,480	5,600	4,400
6	6,600	13,200	11,225	8,400	6,600
8	8,800	17,600	15,000	11,250	8,800
10	11,000	22,000	18,700	14,000	11,000
12	13,200	26,400	22,440	16,800	13,200
14	15,400	30,800	26,180	19,600	15,400
16	17,600	35,200	29,920	22,400	17,600
18	19,800	39,600	33,660	25,200	19,800
20	22,000	44,000	37,400	28,000	22,000

Table 5-2. 12-Gauge Medium Duty Steel Mesh Sling\*

Nominal Width of Sling (in.)	Choker	Vertical Basket	30° Vertical 60° Horizontal	45° Vertical 45° Horizontal	60° Vertical 30° Horizontal
2	1,450	2,900	2,320	1,740	1,450
3	2,175	4,350	3,700	2,700	2,175
4	2,900	5,800	4,900	3,670	2,900
6	4,800	9,600	8,150	6,100	4,800
8	6,400	12,800	10,880	8,100	6,400
10	8,000	16,000	13,600	10,200	8,000
12	9,600	19,200	16,300	12,000	9,600
14	11,200	22,400	19,000	14,000	11,200
16	12,800	25,600	21,700	16,200	12,800
18	13,500	27,000	22,900	17,000	13,500
20	15,000	30,000	25,500	19,000	15,000

Table 5-3. 14-Gauge Light Duty Steel Mesh Sling\*

Nominal Width of Sling (in.)	Choker	Vertical Basket	30° Vertical 60° Horizontal	45° Vertical 45° Horizontal	60° Vertical 30° Horizontal
2	900	1,800	1,600	1,300	900
3	1,400	2,800	2,400	2,000	1,400
4	2,000	4,000	3,500	2,800	2,000
6	3,000	6,000	5,200	4,200	3,000
8	4,000	8,000	6,900	5,700	4,000
10	5,000	10,000	8,600	7,100	5,000
12	6,000	12,000	10,400	8,500	6,000
14	7,000	14,000	12,100	9,900	7,000
16	8,000	16,000	13,900	11,300	8,000
18	9,000	18,000	15,600	12,700	9,000
20	10,000	20,000	17,300	14,100	10,000

### \*WARNING

Do not exceed rated capacities.



# STEEL MESH SLINGS

*Amick Associates, Inc.*

version #2-04

*This Page Intentionally Left Blank*

# WEB & SYNTHETIC SLINGS

## **Introduction**

Sling Designs, Calculations and Adjustments  
Examples of Wear & Abuse

## **Eye & Eye-Flat / Eye & Eye-Twist**

Heavy Duty Web Slings

## **Endless AEN**

Heavy Duty Web Slings

## **PolyFlex™ Round Slings**

PolyFlex Eye & Eye/Endless Round Slings  
Wide-Lift PolyFlex  
PolyFlex Braided Round Slings  
PolyFlex Bridle & Basket Round Slings

## **PowerFlex Round Slings**

High Capacity Round Slings

## **UltraWeb Nylon Slings**

## **Reversed Eye ARE**

## **Triangle-Choker ATC**

## **Triangle-Triangle ATT**

## **Wide Lift Basket AWLB**

Heavy Duty & Light Duty

## **Amick Multi-Leg Bridles**

## **Web Shackles & Fittings**

Sling Saver Web Connector  
Sling Saver Fittings  
Sling Saver Web Sling Shackles  
Sling Saver Web Sling Hooks

## **Optional Pads & Wear Protection**

## **Amick Load Snugger Tie Downs**

## **Amick 3-Inch & 4-Inch Truck Tie Down Assemblies**

## **Nylon Inspection & Repair**

## Introduction

### Introduction

#### Slings are Designed to Provide Specific Rated Capacities and Performance

Each of the 10 standard sling types, as well as other special web devices in this handbook, is designed for a specific lifting application. In addition to their functional design, however, all are engineered specifically for quality and performance, and to provide reliable Rated Capacity to guide the user.

#### Rated Capacity

Several factors are taken into consideration when calculating Rated Capacity of a sling. These include webbing strength, a fabrication factor for each sling type, a hardware strength factor when applicable, and a Design Factor.

Web tensile strength is the foundation and starting point for the calculation. Webbing is manufactured with a specified nominal strength (in pounds per inch of width), in two basic grades. The webbing manufacturer is required to meet or exceed these nominal strengths, and to provide documentation of conformance. Any variation from nominal must be above these ratings. The nominal strength of the webbing is used to calculate sling Rated Capacity.

The second step in calculating sling Rated Capacity involves application of a “fabrication factor” — which compensates for the reduction in webbing strength that occurs due to stitching and tapering. The extent of strength reduction depends on the amount of stitching required for each sling design. For example, two-ply slings require more stitching than one-ply slings, therefore the fabrication factor is greater for a two-ply sling. Another factor is applied when webbing must be tapered, as in an eye.

Hardware strength becomes a factor in calculating sling Rated Capacity only when nominal strength of the hardware is lower than nominal strength of the webbing. When this is the case, the nominal strength of the hardware is used as the basis for the Rated Capacity calculation.

After web nominal strength has been adjusted by applying the fabrication factor, the sling Rated Capacity is then determined by applying a Design Factor of 5 to 1, — as specified by American National Standards Institute (ANSI) standard ANSI B30.9, Section 9-5.2. ANSI and OSHA require that the manufacturer must support published sling ratings with records of test data that verify conformity.

All these factors are necessary in the calculation of sling Rated Capacity. As an added quality control measure, slings are selected at random from production runs for testing. This ongoing program is designed to assure that every new sling meets or exceeds specifications and the Rated Capacity shown in this handbook.

After fabrication, a heavy duty tag showing Rated Capacity is sewn to each sling, and each sling is identified in such a manner that it can be traced back to the manufacturing work order under which it was produced. At any future time, it is possible to determine from permanent file records the sources and specification of webbing and hardware, and even the machine operator who made a sling — the ultimate expression of corporate responsibility and quality assurance.

#### Every Lift Uses 1 of 3 Basic Hitches

**Straight**, or vertical, attachment is simply using a sling to connect a lifting hook to a load. Full rated lifting capacity of the sling may be utilized, but must not be exceeded. A tagline should be used to prevent load rotation that may damage the sling.

When two or more slings are attached to the same lifting hook, the total hitch becomes, in effect, a lifting bridle, and the load is distributed equally among the individual slings.

**Choker** hitches reduce lifting capability of a sling, since this method of rigging affects ability of the sling body to adjust during the lift. A choker is used when the load will not be seriously damaged by the sling body — or the sling damaged by the load, and when the lift requires the sling to snug up against the load.

The diameter of the bend where the sling contacts the load should keep the point of choke against the sling BODY — never against a splice or the base of the eye. When a choke is used at an angle of less than 120° (see facing page) the sling rated capacity must be adjusted downward.

A choker hitch should be pulled tight before a lift is made — NOT PULLED DURING THE LIFT. It is also dangerous to use only one choke hitch to lift a load which might shift or slide out of the choke.

**Basket** hitches distribute a load equally between the two legs of a sling — within limitations described on the facing page.



**Straight or Vertical Attachment**



**Choker Hitch**



**Basket Hitch**

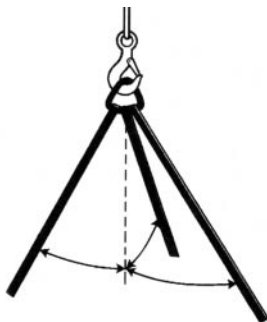
### Calculating the Load on Each Leg of a Sling

As the horizontal angle of sling decreases, the load on each leg increases. The effect is the same whether a single sling is used as a basket, or two slings are used with each in a straight pull, as with a 2-legged bridle.

Any pull is exerted at an angle on a leg — or legs — of a sling, the load per leg can be determined by using the data in Table 6-1 below. Proceed as follows to calculate this load — and determine the rated capacity required of the sling, or slings, needed for a lift.

**Table 6-1. Leg Angle versus Load Factor**

Leg Angle (Degrees)	Load Factor
90°	1.000
85°	1.003
80°	1.015
75°	1.035
70°	1.064
65°	1.103
60°	1.154
55°	1.220
50°	1.305
45°	1.414
40°	1.555
35°	1.743
30°	2.000



Sling Angle of 45°

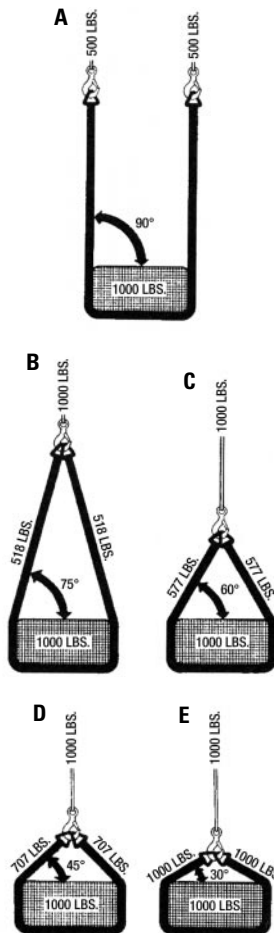
1. First, divide the total load to be lifted by the number of legs to be used. This provides the load per leg if the lift were being made with all legs lifting vertically.
2. Determine the angle between the legs of the sling and the horizontal.
3. Then MULTIPLY the load per leg (as computed in No. 1) by the Load Factor for the leg angle being used (from the table to the left) to compute the ACTUAL LOAD on each leg for this lift and angle. THE ACTUAL LOAD MUST NOT EXCEED THE RATED SLING CAPACITY.

### Examples:

- In drawing **A** below (sling angle at 90°):  $1000 \div 2 = 500$  (Load Per Leg if a vertical lift).
- In drawing **C** below (sling angle at 60°):  $500 \times 1.154 = 577$  lbs. = ACTUAL LOAD on each leg at the 60° included angle being used.
- In drawing **D** below (sling angle at 45°):  $500 \times 1.414 = 707$  lbs. = ACTUAL LOAD on each leg at the 45° horizontal angle being used.

### Angle of Bridles

The horizontal angle of bridles with 3 or more legs is measured the same as the horizontal sling angle of 2-legged hitches. In this case where a bridle designed with different leg lengths results in horizontal angles, the leg with the smallest horizontal angle will carry the greatest load. Therefore, the smallest horizontal angle is used in calculating actual leg load and evaluating the rated capacity of the sling proposed.



### Sling Eye Design

Sling eyes are designed to provide what amount to “small inverted slings” at the ends of the sling body. Therefore, the width of the eye opening will be affected by the same general forces which apply to legs of a sling rigged as a basket.

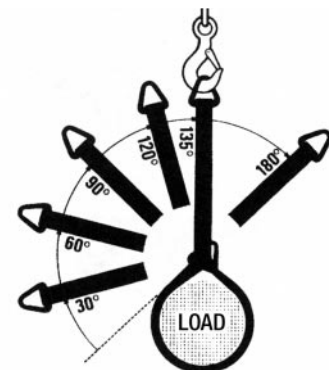
A sling eye should never be used over a hook or pin with a body diameter larger than the natural width of the eye. Never force an eye onto a hook.



**Table 6-2. Choker Hitch — Rated Capacity Adjustment**

Choke Angle (Degrees)	Rated Capacity Percent ①
121 – 135°	100
90 – 120°	87
60 – 89°	74
30 – 59°	62
Up to 29°	49

① Percent of sling rated capacity in a choker hitch.



When a choker hitch is drawn tight at an angle of less than 120°, the Choker Hitch Rated Capacity shown in the sling Rated Capacity Tables must be reduced to allow for loss of Rated Capacity. In controlled tests, where the angle was less than 120°, the sling body always failed at the point of choke when pulled to destruction. Allowance for this phenomenon must be made anytime a choker hitch is used to shift, turn or control a load, or when the pull is against a choke in a multi-leg lift.

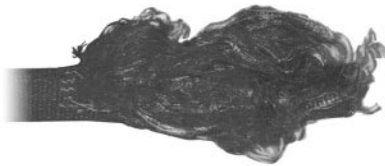
## Introduction

### Examples of Wear & Abuse

Far too many web slings have to be discarded prematurely simply because abusive and careless work habits caused irreparable damage. Following are examples of damage typically caused by abuse and misuse. Regardless of whether a sling shows damage from abuse or normal wear, the overriding rule in all cases is that sling eyes should be cut and the sling discarded immediately whenever damage is detected.

#### Tensile Break

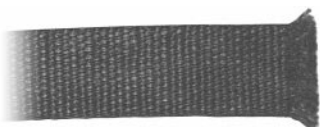
A tensile break is characterized by a frayed appearance at the point of failure or damage. Such damage is caused by loading the sling beyond its existing strength. The example pictured was pulled to destruction on a testing machine.



**Tensile Break**

#### Cuts

A cut is easily identified by a clean break in the webbing structure or fibers, and usually results from the sling contacting a sharp object or unprotected edge of a load. Such damage may be found anywhere in the body or eyes of a web sling. Red Guard warning yarns, described on Page 6-20, are woven into webbing of many slings to provide a warning when a serious cut has occurred. Cuts from contact with sharp corners during lifts can often be avoided by using wear pads on the sling for protection of the fabric. Wear pads are described on Page 6-20.



**Cut**

#### Cut and Tensile Damage

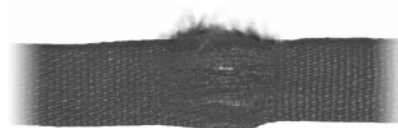
The sample shown below illustrates a typical shop failure in which a sling is used after having received a cut by a sharp object along one edge of the sling body. The cut severely reduces lifting capacity, and continued usage will result in the sling breaking much as shown. Such a failure often occurs at a level far below the Rated Capacity of a sling.



**Cut and Tensile Damage**

#### Abrasion Damage

The most common abrasion damage occurs either when a sling slips while in contact with a load during a lift, or when being pulled from under a load. Abrasion is characterized by frayed fibers on the surface which exposes the “picks,” or cross-fibers of the webbing that hold in place the load-bearing (lengthwise) fibers. Further abrasion at this point will expose the Red Guard warning yarns to signal the inspector or sling user that serious damage — and the loss of lifting capacity — has occurred. Any damage to load-bearing fibers should be viewed critically.



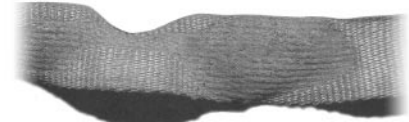
**Abrasion Damage**

#### Acid Damage

Although Polyester webbing has considerable resistance to certain acids — and Nylon should never be exposed to possible contact with an acid — any contact with strong acids should be avoided. Metal fittings on slings should not be exposed to any acid or corrosive liquid.

**Example A** — The damage shown here to Nylon webbing occurred when sulfuric acid (such as used in an automobile battery) was heated to 100°C (212°F) and dropped on the webbing. The charring of surface fibers seen here is typical of acid damage. The deterioration shown will continue over time and severely affect webbing strength.

**Example B** — A piece of Nylon webbing was immersed in sulfuric acid at room temperature for three weeks, resulting in the significant damage shown. Note that fibers are softened and swollen, and the entire fabric is grossly distorted, virtually destroying the webbing. Precautions should be taken never to store slings where they may be exposed to acid fumes (which can be as destructive as liquid), or to possible contact with acid.



**Acid Damage**



**Burn Damage**

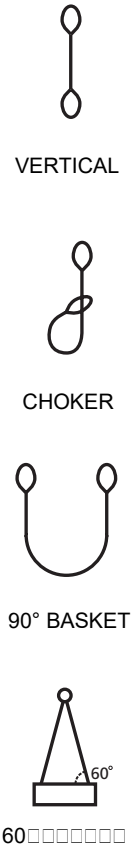
### Heavy Duty

Polyester or Nylon®

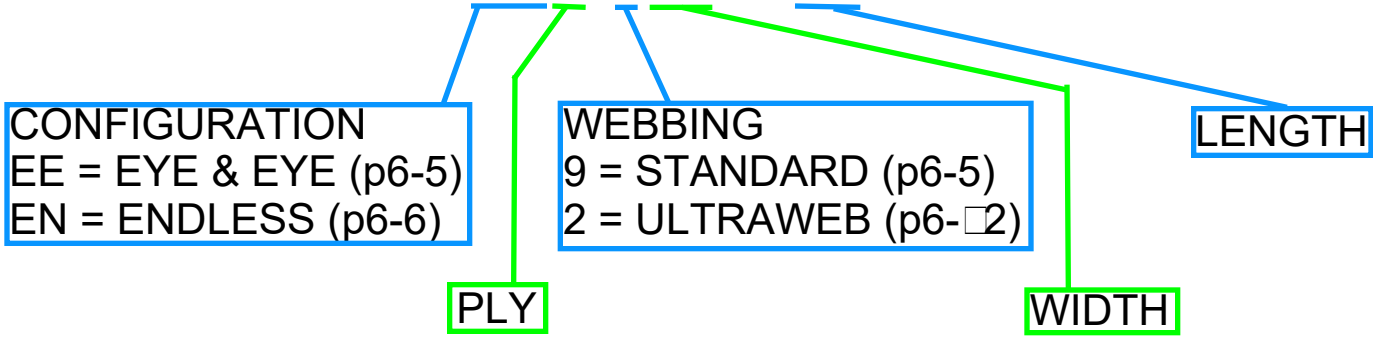


Table 6-3. Eye & Eye-Flat / Eye & Eye-Twist — Heavy Duty (Rated Capacity in Pounds)

Stock Number	Width (in.)	Ply	Vertical	Choker	Basket Hitch	
					Basket 90°	60°
EE1-901	1	1	1,600	1,280	3,200	2,800
EE2-901	1	2	3,100	2,480	6,200	5,400
EE3-901	1	3	4,700	3,760	9,400	8,100
EE4-901	1	4	5,500	4,400	11,000	9,500
EE1-902	2	1	3,100	2,480	6,200	5,400
EE2-902	2	2	6,200	4,960	12,400	10,700
EE3-902	2	3	9,300	7,440	18,600	16,100
EE4-902	2	4	11,000	8,800	22,000	19,000
EE1-903	3	1	4,700	3,760	9,400	8,100
EE2-903	3	2	8,800	7,040	17,600	15,200
EE3-903	3	3	13,500	10,800	27,000	23,350
EE4-903	3	4	16,450	13,160	32,900	28,500
EE1-904	4	1	6,200	4,960	12,400	10,700
EE2-904	4	2	11,000	8,800	22,000	19,100
EE3-904	4	3	17,200	13,760	34,400	29,750
EE4-904	4	4	20,400	16,320	40,800	35,300
EE1-906	6	1	9,300	7,440	18,600	16,100
EE2-906	6	2	16,500	13,200	33,000	28,600
EE3-906	6	3	24,400	19,520	48,800	42,250
EE4-906	6	4	30,600	24,480	61,200	53,000
EE1-908	8	1	11,750	9,440	21,150	18,300
EE2-908	8	2	22,750	18,200	42,350	36,700
EE3-908	8	3	30,700	24,560	61,400	53,150
EE4-908	8	4	41,000	32,800	82,000	71,000
EE1-910	10	1	14,700	11,760	26,450	22,900
EE2-910	10	2	28,400	22,720	52,900	45,800
EE3-910	10	3	36,000	28,800	72,000	62,300
EE4-910	10	4	48,000	38,400	96,000	83,100
EE1-912	12	1	17,650	14,120	31,750	27,450
EE2-912	12	2	34,100	27,280	63,500	55,000
EE3-912	12	3	40,300	32,240	80,600	69,750
EE4-912	12	4	60,000	48,000	120,000	103,900



## HOW TO ORDER EE2-902 X 20



Ⓢ Standard web slings made from Polyester, Nylon available on request

# WEB & SYNTHETIC

Amick Associates, Inc.

## Endless AEN

version #1-23

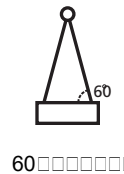
### Heavy Duty

Polyester or Nylon®



Table 6-4. Endless — Heavy Duty (Rated Capacity in Pounds)

Stock Number	Width (in.)	Ply	Vertical	Choker	Basket Hitch	
					Basket 90°	60°
EN1-901	1	1	3,200	2,560	6,400	5,500
EN2-901	1	2	6,200	4,960	12,400	10,700
EN3-901	1	3	9,600	7,680	19,200	16,600
EN4-901	1	4	11,000	8,800	22,000	19,050
EN1-902	2	1	6,200	4,960	12,400	10,700
EN2-902	2	2	12,400	9,920	24,800	21,450
EN3-902	2	3	17,700	14,160	35,400	30,650
EN4-902	2	4	22,000	17,600	44,000	38,100
EN1-903	3	1	9,400	7,520	18,800	16,250
EN2-903	3	2	17,600	14,080	35,200	30,450
EN3-903	3	3	25,600	20,480	51,200	44,300
EN4-903	3	4	32,900	26,320	65,800	56,950
EN1-904	4	1	12,400	9,920	24,800	21,450
EN2-904	4	2	22,000	17,600	44,000	38,100
EN3-904	4	3	34,600	27,680	69,200	59,900
EN4-904	4	4	40,800	32,640	81,600	70,650
EN1-906	6	1	18,600	14,880	37,200	32,200
EN2-906	6	2	33,000	26,400	66,000	57,150
EN3-906	6	3	48,900	39,120	97,800	84,650
EN4-906	6	4	61,200	48,960	122,400	105,950
EN1-908	8	1	21,150	16,920	42,300	36,600
EN2-908	8	2	42,350	33,880	84,700	73,300
EN3-908	8	3	61,400	49,120	122,800	106,350
EN4-908	8	4	81,900	65,520	163,800	141,800
EN1-910	10	1	26,450	21,160	52,900	45,800
EN2-910	10	2	52,900	42,320	105,800	91,600
EN3-910	10	3	72,000	57,600	144,000	124,650
EN4-910	10	4	96,000	76,800	192,000	166,250
EN1-912	12	1	31,750	25,400	63,500	54,950
EN2-912	12	2	63,500	50,800	127,000	109,950
EN3-912	12	3	80,600	64,480	161,200	139,550
EN4-912	12	4	107,000	85,600	214,000	185,300



Standard web slings made from Polyester, Nylon available on request

①

### PolyFlex™ Round Slings\*

We've combined "POLY" and "FLEX" to give you PolyFlex, the round sling that lifts many loads most other types of slings can't. With loads of flexibility, it wraps easily around a wide variety of difficult loads to give you loads of lifting security.

#### Loads of Security

##### PolyFlex Hugs and Grips Many Unusual Loads

PolyFlex isn't made like other types of slings. As a round sling, it features multiple loops of polyester fibers encased in a double-layer jacket that's very flexible and supple. Perfect for hugging many uneven and odd shaped loads. Its soft design also grips many loads tightly — especially when used as a choker — to reduce slipping during the lift. By simply adjusting the flexible sling, you can lift a variety of loads of different sizes and shapes.

##### Low-Stretch Design Makes Rigging Easier

PolyFlex slings feature a 100% polyester construction that stretches approximately 3% at its rated capacity and still returns to its original length. That minimizes adjustments for stretch and reduces headroom problems of your lift.

##### Light in Weight, But High in Strength

PolyFlex slings may have a soft, pliable appearance on the outside, but they contain high-strength polyester fibers on the inside. These fibers run throughout the sling's body for high load-bearing capacity. Choose from several rated capacities to match your lifting requirements (see chart on facing page).

#### Two Layers of Protection

A double-layer polyester jacket helps protect the PolyFlex sling interior from two major enemies: abrasion and wear. It also serves as an effective barrier against ultraviolet degradation of the internal load-bearing fibers as well as harmful dirt and debris. Protection like this pays off in long-term performance in your sling.

#### Polyester Offers Loads of Advantages

The all-polyester construction virtually eliminates moisture absorption, rot and mildew for long service life. It also offers good resistance to common industrial acids (except concentrated sulfuric acid) and hot bleaching solutions. You can use PolyFlex slings in the presence of many common chemicals such as alcohol, dry cleaning solvent, hydrocarbons, halogenated hydrocarbons, ketones, crude oil, lubricating oils, soaps, detergents, seawater and weak alkali.

#### Be Careful

- Do not expose PolyFlex slings to strong alkalis at elevated temperatures, and never use at temperatures above 194°F (90°C) or below -40°F (-40°C).
- Avoid sling contact with any kind of sharp surfaces.
- Do not overload any sling beyond its rated capacity to prevent permanent stretch and weakening.

#### \* WARNING

Failure to follow proper care, use and inspection criteria may result in personal injury. Do not exceed rated capacities.

# WEB & SYNTHETIC

## PolyFlex™ Round Slings\*

### PolyFlex™ Eye & Eye/Endless Round Slings

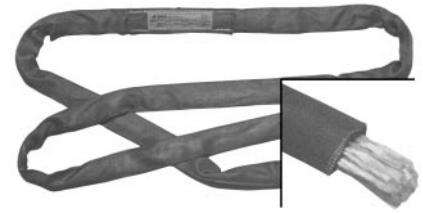
Each sling body is constructed of an endless loop of polyester fibers encased in a double-layer woven jacket.

Unique PolyFlex Sling construction produces outstanding handling and rigging characteristics. The sling body is exceptionally supple, conforms readily to uneven and oddly shaped loads during a lift. Additionally, the sling has a softness which provides a firm gripping action on the load, particularly when used as a choker. The 100% polyester construction also provides extremely low (3%) elongation at rated loading.

High-strength, low-stretch polyester fibers run continuously, circumferentially in the PolyFlex sling body to develop the lifting capacity designed into each model. A double-walled polyester fabric jacket is sewn permanently in place to contain and protect the load-bearing fibers.

In addition to protecting the main body of the sling from abrasion and other damage, the jacket prevents sunlight from penetrating the body and causing ultra-violet degradation of the polyester fibers. Dirt and grime are also kept away from the load-bearing core of the sling by the jacket. Because it is 100% polyester moisture absorption, rot and mildew are virtually non-existent.

Polyester offers good resistance to common industrial acids (except concentrated sulfuric acid) and hot bleaching solutions. Slings may be used in the presence of alcohol, dry cleaning solvent, hydrocarbons, halogenated hydrocarbons, ketones, crude oil, lubricating oil, soaps, detergents, seawater and weak alkalis, but should NOT be exposed to strong alkalis at elevated temperatures, and should never be used under temperature conditions above 200°F.



Vertical



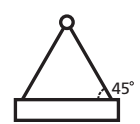
Choker



Vertical Basket



60° Basket



45° Basket

Table 6-5. PolyFlex Eye & Eye / Endless Roundslings (Rated Capacity in Pounds)

Stock Number	Body Dia. Approx. (in.)	Weight Per ft. (2 Legs) lbs.	Vertical	Choker	Basket Hitch			Color Code
					Vertical Basket	60°	45°	
APF 01EN	.60	.30	2,600	2,100	5,200	4,500	3,700	Purple
APF 02EN	.80	.40	5,300	4,200	10,600	9,200	7,500	Green
APF 03EN	1.00	.50	8,400	6,700	16,800	14,500	11,900	Yellow
APF 04EN	1.20	.60	10,600	8,500	21,200	18,400	15,000	Tan
APF 05EN	1.30	.80	13,200	10,600	26,400	22,900	18,700	Red
APF 06EN	1.40	.90	16,800	13,400	33,600	29,100	23,800	White
APF 07EN	1.55	1.20	21,200	17,000	42,400	36,700	30,000	Blue
APF 08EN	1.75	1.50	25,000	20,000	50,000	43,300	35,400	Orange
APF 09EN	1.95	2.00	31,000	24,800	62,000	53,700	43,800	Orange
APF 10EN	2.35	2.80	40,000	32,000	80,000	69,300	56,600	Orange
APF 11EN	3.15	3.60	53,000	42,400	106,000	91,800	74,900	Orange
APF 12EN	3.95	4.60	66,000	52,800	132,000	114,300	93,300	Orange
APF 13EN	4.80	5.80	90,000	72,000	180,000	155,900	127,300	Orange

## Wide-Lift PolyFlex

### Wide Load Support & Balance

Combine stability, strength and economy.

Table 6-6. Wide-Lift PolyFlex

Code	Color of Eyes	Vertical Basket Hitch Capacity
AWL30	Purple	5,200
AWL60	Green	10,600
AWL90	Yellow	16,800
AWL120	Tan	21,200



## PolyFlex™ Braided Round Slings

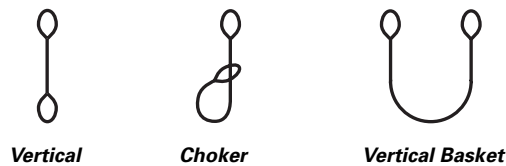
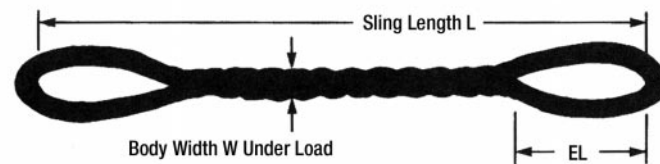
**Huge Capacities of Over 350,000 lbs. are Available**

- 6 Part Flat
- 8 Part Round

For the ultimate in big loads or for the security of multiple part sling lifting.

Braided PolyFlex sling advantages:

- Standard basket capacities up to 359,600 lbs.
- Higher capacities available on special order.
- Multiple part construction for redundant safety concept.
- Extremely flexible — light weight.
- Protected loop ends and eyes.
- Wear pads are available.
- Braided slings retain the basic PolyFlex™ features of: color coding, pliability and easy inspection.



**Table 6-7. PolyFlex Braided Roundslings**

Code	Color	Rated Capacity (lbs.)*			Approximate Weights and Dimensions					
		Vertical	Choker	Basket	(L) Min. Length (in.)	Weight lb./ft.	(EL) Std. Eye Length	Body Under Load (in.)		
							Width	Thickness		
<b>6 Part PolyFlex Braided Roundslings</b>										
APFB601	Purple	6,700	5,300	13,400	4-1/2	.80	13-1/2	3-1/4	3/4	
APFB602	Green	13,500	10,800	27,000	5	1.20	15	3-3/4	1-1/8	
APFB603	Yellow	21,400	17,100	42,800	5-1/2	1.60	18	4-1/4	1-1/4	
APFB604	Tan	27,000	21,600	54,000	5-1/2	2.00	18	4-1/2	15/16	
APFB605	Red	33,600	26,800	67,200	6-1/2	2.70	25	5-1/4	1-3/4	
APFB606	White	42,800	34,200	85,600	7	3.20	25	5-1/2	2	
APFB607	Blue	54,000	43,200	108,000	9	4.40	30	6-5/8	2-1/4	
APFB608	Grey	71,250	57,000	142,000	9-1/2	6.50	33	8-1/4	2-1/2	
APFB609	Brown	88,350	70,680	176,700	10-1/2	9.70	38	11	2-3/4	
<b>8 Part PolyFlex Braided Roundslings</b>										
APFB801	Purple	9,000	7,200	18,000	4-1/2	1.10	15	3-1/2	1	
APFB802	Green	18,000	14,400	36,000	5	1.50	15	4	1-3/8	
APFB803	Yellow	28,500	22,800	57,000	5-1/2	2.20	15	4-3/4	1-5/8	
APFB804	Tan	36,000	28,800	72,000	5-1/2	2.60	15	5	1-3/4	
APFB805	Red	44,900	35,900	89,800	6-1/2	3.60	20	6	2-1/8	
APFB806	White	57,100	45,600	114,200	7	4.10	20	6-1/4	2-1/2	
APFB807	Blue	72,000	57,600	144,000	9	5.60	20	7-1/2	2-3/4	
APFB808	Grey	95,000	76,000	190,000	9-1/2	8.30	30	9-1/2	3-1/4	
APFB809	Brown	117,800	94,240	235,600	10-1/2	12.00	30	13	3-3/4	

**\*WARNING** Do not exceed rated capacities.

# WEB & SYNTHETIC

Amick Associates, Inc.

version #1-23

## PolyFlex™ Round Slings\*

### PolyFlex™ Bridle & Basket Round Slings

PolyFlex Regular, Custom Bridles and Basket Slings make sense in many applications.

- Better load control that comes with bridles and baskets.
- Protect the load between the pick-up point and the crane hook.
- Lighter weight and easier to store than wire rope or chain slings.

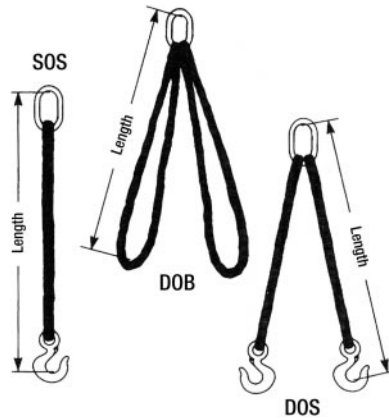
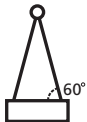


Table 6-8. Description of Digits

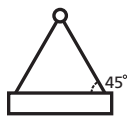
1st Digit	2nd Digit	3rd Digit
Number of Legs	Master Link	Leg Bottom Attachment
S-Single (1) D-Double (2) T-Triple (3) Q-Quad (4)	O-Oblong P-Pear (non-Std) R-Ring	S-Sling Hook F-Foundry Hook L-Latchlok Hook O-Oblong Link P-Pear Link R-Ring B-Basket

Table 6-9. Single Leg Slings

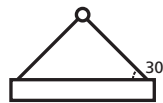
Code	Color	Oblong Link (in.)	Hook Size in Tons	Vertical Capacity in lbs.
APFBB01	Purple	1/2	1-1/2	2,650
APFBB02	Green	3/4	3	5,300
APFBB03	Yellow	3/4	5	8,400
APFBB04	Tan	3/4	7-1/2	10,600
APFBB05	Red	1	7-1/2	13,200
APFBB06	White	1	10	16,800
APFBB07	Blue	1-1/4	15	21,200



60° Basket



45° Basket



30° Basket

Table 6-10. Double Leg Slings

Oblong Link (in.)	Rated Capacity (lbs.)		
	60°	45°	30°
3/4	4,500	3,700	2,600
3/4	9,100	7,500	5,300
1	14,500	11,800	8,400
1-1/4	18,300	14,900	10,600
1-1/4	22,800	18,600	13,200
1-1/2	29,000	23,700	16,800
1-3/4	36,700	29,900	21,200

### Care, Use and Inspection Instructions for ALL PolyFlex Slings

- PolyFlex slings may not be used at temperatures above 200°F. If the sling has been exposed to temperatures above 200°F, it must be immediately removed from service.
- PolyFlex slings shall not be used with loads greater than the rated capacity.
- PolyFlex slings must not be in contact with sharp or rough edges.
- PolyFlex slings must not be exposed to fumes, vapors, sprays, mists or liquids of alkalis, aldehydes, ethers, or concentrated sulfuric acid.
- PolyFlex slings must be immediately removed from service if any of the following are present:
  - Acid or caustic burns.
  - Melting or charring of any part of the sling.
  - Snags, cuts, or punctures that expose the white core fibers.
  - Distortion of fittings.
- Never lift over people.
- Loads must not slip or slide as the sling may become damaged and failure could occur.
- Inspect slings prior to each use.
- Slings must be used in accordance with the angle of lift charts.

#### \*WARNING

Failure to follow proper care, use and inspection criteria may result in personal injury. Do not exceed rated capacities.

### PowerFlex High Capacity Round Slings

Similar in design to our PolyFlex round slings, PowerFlex round slings use EHP-V hybrid blend core yarns to achieve greater lifting capacities. We also use a tough double jacket with a texturized nylon outer layer to protect the sling from damage.

Table 6-11 PowerFlex Round Slings

Stock Number	Vertical	Choker	Basket Hitch	
			90° Basket	60° Basket
APFEHP10EN or EE	10,000	8,000	20,000	17,320
APFEHP15EN or EE	15,000	12,000	30,000	25,980
APFEHP20EN or EE	20,000	16,000	40,000	34,640
APFEHP25EN or EE	25,000	20,000	50,000	43,300
APFEHP30EN or EE	30,000	24,000	60,000	51,960
APFEHP40EN or EE	40,000	32,000	80,000	69,280
APFEHP50EN or EE	50,000	40,000	100,000	86,139
APFEHP60EN or EE	60,000	48,000	120,000	103,920
APFEHP70EN or EE	70,000	56,000	140,000	121,240
APFEHP85EN or EE	85,000	68,000	170,000	147,220
APFEHP100EN or EE	100,000	80,000	200,000	173,200
APFEHP125EN or EE	125,000	100,000	250,000	216,500
APFEHP150EN or EE	150,000	120,000	300,000	259,800
APFEHP175EN or EE	175,000	140,000	350,000	303,100
APFEHP200EN or EE	200,000	160,000	400,000	346,400
APFEHP250EN or EE	250,000	200,000	500,000	433,000
APFEHP275EN or EE	275,000	220,000	550,000	476,300
APFEHP300EN or EE	300,000	240,000	600,000	519,600



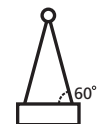
VERTICAL



CHOKER



90° BASKET



60° BASKET



**WARNING**

Do not exceed rated capacities.

# WEB & SYNTHETIC

## UltraWeb™ Nylon Slings

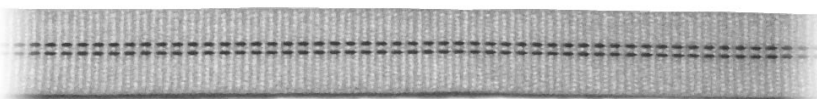
### UltraWeb™ Nylon Slings

#### Best in Abrasion Resistance

#### UltraWeb 2000

Two stripes = 2,000 lbs. per inch of width (one ply only). UltraWeb slings are made with the strongest abrasion resistant sling available.

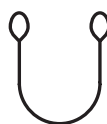
- 25% stronger than other webbing.
- Abrasion resistant Cordura® covering faces and edges.
- Striped capacity identification.
- Red core yarn warning system.



Vertical



Choker



Vertical Basket

Table 6-12. UltraWeb 2000 Capacity — Type U

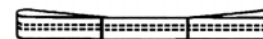
Ply	Code	Web Width (in.)	Rated Capacity (lbs.)		
			Vertical	Choker	Vertical Basket
One Ply	UU1-202	2	4,000	3,200	8,000
	UU1-203	3	6,000	4,800	12,000
	UU1-204	4	8,000	6,400	16,000
Two Ply	UU2-202	2	8,000	6,400	16,000
	UU2-203	3	10,800	8,600	21,600
	UU2-204	4	14,400	11,500	28,800



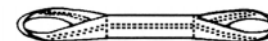
Type U

Table 6-13. UltraWeb 2000 Capacity — Type 3 & Type 4

Ply	Code	Web Width (in.)	Rated Capacity (lbs.)		
			Vertical	Choker	Vertical Basket
One Ply	EE1-201	1	2,000	1,600	4,800
	EE1-202	2	4,000	3,200	8,000
	EE1-203	3	6,000	4,800	12,000
	EE1-204	4	8,000	6,400	16,000
Two Ply	EE2-201	1	4,000	3,200	8,000
	EE2-202	2	8,000	6,400	16,000
	EE2-203	3	10,800	8,600	21,600
	EE2-204	4	14,400	11,600	28,800



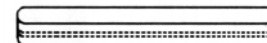
Type 3



Type 4

Table 6-14. UltraWeb 2000 Capacity — Type 5

Ply	Code	Web Width	Rated Capacity (lbs.)		
			Vertical	Choker	Vertical Basket
One Ply	EN1-201	1	4,000	3,200	8,000
	EN1-202	2	8,000	6,400	16,000
	EN1-203	3	12,000	9,600	24,000
	EN1-204	4	16,000	12,800	32,000
Two Ply	EN2-201	1	7,800	6,200	15,600
	EN2-202	2	15,200	12,200	30,400
	EN2-203	3	20,400	16,300	40,800
	EN2-204	4	25,800	20,600	51,600



Type 5

**Note:** Eyes of UltraWeb 2000 slings for Types 3-4-5 are not tapered in any width.

**Note:** UltraWeb slings meet or exceed OSHA and ASME/ANSI B30.9 requirements.

**Reversed Eye ARE**

**Wear Pads Both Sides and In Eyes**

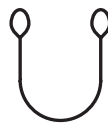
An exceptionally durable sling that features full body and eye protection. The eye openings are 90° to the sling body for tighter choker hitches and easy vertical and basket hitch rigging. Slings of the same construction as Type 6 except that the eyes are on the same plane as the sling body. The flat eye permits rigging through narrower openings and easier removal from under loads. Rigs effectively in choker and basket hitches.



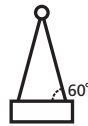
Vertical



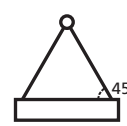
Choker



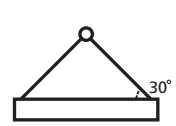
Vertical Basket



60° Basket



45° Basket



30° Basket

**Table 6-15. Reversed Eye ARE (Rated Capacity in Pounds)**

Stock Number	Width (in.)	Ply	Vertical	Choker	Basket Hitch				Eye Width (in.)	Eye Length (in.)
					Vert. Basket	60°	45°	30°		
-1-602	2	1	2,400	1,920	4,800	4,156	3,394	2,400	1	9
-1-802	2	1	3,200	2,560	6,400	5,542	4,525	3,200	1	9
-2-602	2	2	4,800	3,840	9,600	8,313	6,788	4,800	1	12
-2-802	2	2	6,400	5,120	12,800	11,084	9,050	6,400	1	12
-1-604	4	1	4,800	3,840	9,600	8,313	6,788	4,800	2	12
-1-804	4	1	6,400	5,120	12,800	11,000	9,050	6,400	2	12
-2-604	4	2	9,600	7,680	19,200	16,627	13,576	9,600	2	12
-2-804	4	2	12,800	10,240	25,600	22,169	18,101	12,800	2	12
-3-604	4	3	13,320	10,656	26,640	23,070	18,837	13,320	2	15
-3-804	4	3	17,760	14,208	35,520	30,760	25,116	17,760	2	15
-4-604	4	4	17,760	14,208	35,520	30,760	25,116	17,760	2	15
-4-804	4	4	23,680	18,944	47,360	41,013	33,488	23,680	2	15
-1-606	6	1	7,200	5,760	14,400	12,470	10,182	7,200	1-1/2	12
-1-806	6	1	9,600	7,680	19,200	16,627	13,576	9,600	1-1/2	12
-2-606	6	2	13,320	10,656	26,640	23,070	18,837	13,320	1-1/2	15
-2-806	6	2	17,760	14,208	35,520	30,760	25,116	17,760	1-1/2	15
-3-606	6	3	19,980	15,984	39,960	34,605	28,255	19,980	3	18
-3-806	6	3	26,640	21,312	53,280	46,140	37,674	26,640	3	18
-4-606	6	4	26,640	21,312	53,280	46,140	37,674	26,640	3	18
-4-806	6	4	35,520	28,416	71,040	61,520	50,232	35,520	3	18



# WEB & SYNTHETIC

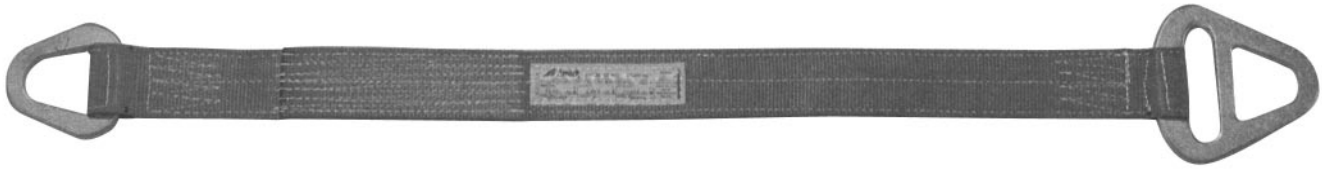
Amick Associates, Inc.

## Triangle-Choker ATC

version #1-23

### Triangle-Choker ATC\*

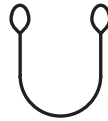
Nylon or Polyester web slings with alloy steel or alloy aluminum end fittings, for use in vertical, choker and basket hitch applications.



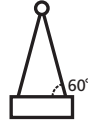
Vertical



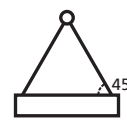
Choker



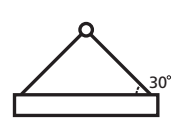
Vertical Basket



60° Basket



45° Basket



30° Basket

Table 6-16. Triangle-Choker ATC (Rated Capacity in Pounds)

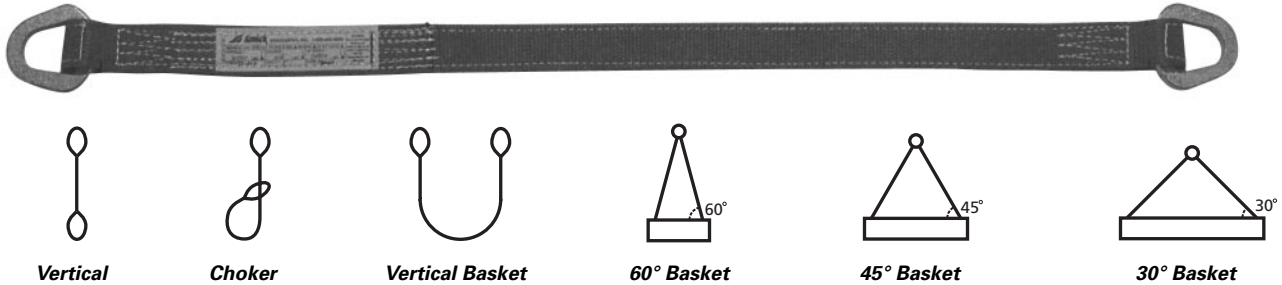
Stock Number	Width (in.)	Ply	Vertical	Choker	Basket Hitch			
					Vertical Basket	60°	45°	30°
ATC-1-602	2	1	2,400	1,920	4,800	4,156	3,394	2,400
ATC-1-802	2	1	3,200	2,560	6,400	5,542	4,525	3,200
ATC-2-602	2	2	4,800	3,840	9,600	8,313	6,788	4,800
ATC-2-802	2	2	6,400	5,120	12,800	11,084	9,050	6,400
ATC-1-603	3	1	3,600	2,880	7,200	6,235	5,091	3,600
ATC-1-803	3	1	4,800	3,840	9,600	8,313	6,788	4,800
ATC-2-603	3	2	6,660	5,328	13,320	11,535	9,418	6,660
ATC-2-803	3	2	8,880	7,104	17,760	15,380	12,558	8,880
ATC-1-604	4	1	4,800	3,840	9,600	8,313	6,788	4,800
ATC-1-804	4	1	6,400	5,120	12,800	11,084	9,050	6,400
ATC-2-604	4	2	8,640	6,912	17,280	14,964	12,218	8,640
ATC-2-804	4	2	11,520	9,216	23,040	19,952	16,291	11,520
ATC-1-605	5	1	6,000	4,800	12,000	10,392	8,485	6,000
ATC-1-805	5	1	8,000	6,400	16,000	13,856	11,313	8,000
ATC-2-605	5	2	10,500	8,400	21,000	18,186	14,849	10,500
ATC-2-805	5	2	14,000	11,200	28,000	24,248	19,798	14,000
ATC-1-606	6	1	7,200	5,760	14,400	12,470	10,182	7,200
ATC-1-806	6	1	9,600	7,680	19,200	16,627	13,576	9,600
ATC-2-606	6	2	12,240	9,792	24,480	21,200	17,309	12,240
ATC-2-806	6	2	16,320	13,056	32,640	28,266	23,079	16,320
ATC-1-808	8	1	12,800	10,240	25,600	22,169	18,101	12,800
ATC-2-808	8	2	20,480	16,384	40,960	35,471	28,962	20,480
ATC-1-810	10	1	16,000	12,800	32,000	27,712	22,627	16,000
ATC-2-810	10	2	24,000	19,200	48,000	41,568	33,940	24,000
ATC-1-812	12	1	19,200	15,360	38,400	33,254	27,152	19,200
ATC-2-812	12	2	26,880	21,504	53,760	46,556	38,013	26,880

**\* WARNING**

Aluminum fittings should not be used where fumes, vapors, sprays, mists, or liquids of caustics are present.

### Triangle-Triangle ATT\*

Nylon or Polyester web slings with alloy steel or alloy aluminum triangles, for use in vertical or basket hitch applications.



**Table 6-17. Triangle-Triangle ATT (Rated Capacity in Pounds)**

Stock Number	Width (in.)	Ply	Vertical	Basket Hitch			
				Vertical Basket	60°	45°	30°
ATT-1-602	2	1	2,400	4,800	4,156	3,394	2,400
ATT-1-802	2	1	3,200	6,400	5,542	4,525	3,200
ATT-2-602	2	2	4,800	9,600	8,313	6,788	4,800
ATT-2-802	2	2	6,400	12,800	11,084	9,050	6,400
ATT-1-603	3	1	3,600	7,200	6,235	5,091	3,600
ATT-1-803	3	1	4,800	9,600	8,313	6,788	4,800
ATT-2-603	3	2	6,660	13,320	11,535	9,418	6,660
ATT-2-803	3	2	8,880	17,760	15,380	12,558	8,880
ATT-1-604	4	1	4,800	9,600	8,313	6,788	4,800
ATT-1-804	4	1	6,400	12,800	11,084	9,050	6,400
ATT-2-604	4	2	8,640	17,280	14,964	12,218	8,640
ATT-2-804	4	2	11,520	23,040	19,952	16,291	11,520
ATT-1-605	5	1	6,000	12,000	10,392	8,485	6,000
ATT-1-805	5	1	8,000	16,000	13,856	11,313	8,000
ATT-2-605	5	2	10,500	21,000	18,186	14,849	10,500
ATT-2-805	5	2	14,000	28,000	24,248	19,798	14,000
ATT-1-606	6	1	7,200	14,400	12,470	10,182	7,200
ATT-1-806	6	1	9,600	19,200	16,627	13,576	9,600
ATT-2-606	6	2	12,240	24,480	21,200	17,309	12,240
ATT-2-806	6	2	16,320	32,640	28,266	23,079	16,320
ATT-1-808	8	1	12,800	25,600	22,169	18,101	12,800
ATT-2-808	8	2	20,480	40,960	35,471	28,962	20,480
ATT-1-810	10	1	16,000	32,000	27,712	22,627	16,000
ATT-2-810	10	2	24,000	48,000	41,568	33,940	24,000
ATT-1-812	12	1	19,200	38,400	33,254	27,152	19,200
ATT-2-812	12	2	26,880	53,760	46,556	38,013	26,880



**\* WARNING** Aluminum fittings should not be used where fumes, vapors, sprays, mists, or liquids of caustics are present.

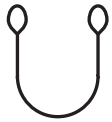
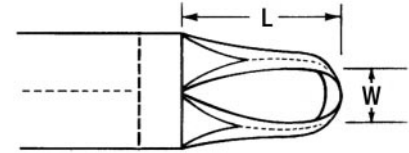
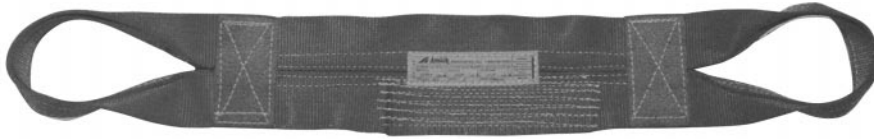
## Wide Lift Basket AWLB

version #1-23

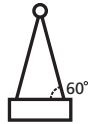
### Wide Lift Basket AWLB

#### Heavy Duty

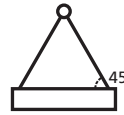
Designed for use in basket hitches where a wide sling is needed for load stability and where width is required for proper handling of fragile or highly finished surfaces. Eyes of slings are tapered to fit on hoist or crane hooks and are reinforced to provide increased durability.



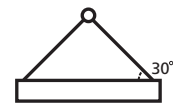
Vertical Basket



60° Basket



45° Basket



30° Basket

Table 6-18. Wide Lift Basket (Rated Capacity in Pounds)

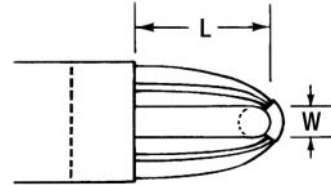
Stock Number	Width (in.)	Ply	Basket Hitch				Eye Length (in.)	Eye Width (in.)
			Vertical Basket	60°	45°	30°		
AWLB-1-606HD	6	1	14,400	12,470	10,182	7,200	12	1-1/2
AWLB-1-806HD	6	1	19,200	16,627	13,576	9,600	12	1-1/2
AWLB-2-606HD	6	2	26,640	23,070	18,837	13,320	15	1-1/2
AWLB-2-806HD	6	2	35,520	30,760	25,116	17,760	15	1-1/2
AWLB-1-608HD	8	1	19,200	16,627	13,576	9,600	12	2
AWLB-1-808HD	8	1	25,600	22,169	18,101	12,800	12	2
AWLB-2-608HD	8	2	34,560	29,928	24,437	17,280	15	2
AWLB-2-808HD	8	2	46,080	39,905	32,583	23,040	15	2
AWLB-1-610HD	10	1	24,000	20,784	16,970	12,000	15	1-3/4
AWLB-1-810HD	10	1	32,000	27,712	22,627	16,000	15	1-3/4
AWLB-2-610HD	10	2	42,000	36,372	29,698	21,000	18	2-1/2
AWLB-2-810HD	10	2	56,000	48,496	39,597	28,000	18	2-1/2
AWLB-1-612HD	12	1	28,800	24,940	20,364	14,400	15	2
AWLB-1-812HD	12	1	38,400	33,254	27,152	19,200	15	2
AWLB-2-612HD	12	2	48,960	42,399	34,619	24,480	18	3 <sup>①</sup>
AWLB-2-812HD	12	2	65,280	56,532	46,159	32,640	18	3 <sup>①</sup>
AWLB-1-816HD	16	1	51,200	44,339	36,203	25,600	18	3 <sup>①</sup>
AWLB-2-816HD	16	2	81,920	70,942	57,925	40,960	24	4 <sup>①</sup>
AWLB-1-820HD	20	1	64,000	55,424	45,254	32,000	24	3-1/2 <sup>①</sup>
AWLB-2-820HD	20	2	96,000	83,136	67,881	48,000	24	5 <sup>①</sup>
AWLB-1-824HD	24	1	76,800	66,508	54,305	38,400	24	4 <sup>①</sup>
AWLB-2-824HD	24	2	107,520	93,112	76,027	53,760	24	6 <sup>①</sup>

① Narrower taper available on special request only.

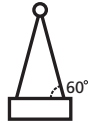
### Wide Lift Basket AWLB

#### Light Duty

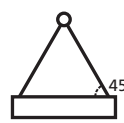
Designed to be used where sling width is required for load stability and for protection of finished surfaces or fragile loads. These slings have lower rated capacity than the Wide Lift Basket. Eyes are constructed to fit properly on small hoist hooks.



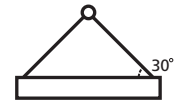
Vertical Basket



60° Basket



45° Basket



30° Basket

**Table 6-19. Wide Lift Basket AWLB — Light Duty (Rated Capacity in Pounds)**

Stock Number	Width (in.)	Ply	Basket Hitch				Eye Width (in.)	Eye Length (in.)
			Vertical Basket	60°	45°	30°		
AWLB-1-606LD	6	1	3,000	2,598	2,121	1,500	1	9
AWLB-1-806LD	6	1	6,000	5,196	4,242	3,000	1	9
AWLB-1-608LD	8	1	3,000	2,598	2,121	1,500	1	12
AWLB-1-808LD	8	1	6,000	5,196	4,242	3,000	1	12
AWLB-1-610LD	10	1	3,000	2,598	2,121	1,500	1	12
AWLB-1-810LD	10	1	6,000	5,196	4,242	3,000	1	15
AWLB-1-612LD	12	1	3,000	2,598	2,121	1,500	1	18
AWLB-1-812LD	12	1	6,000	5,196	4,242	3,000	1	18
AWLB-1-616LD	16	1	5,000	4,330	3,535	2,500	2	18
AWLB-1-816LD	16	1	10,000	8,660	7,071	5,000	2	24
AWLB-1-620LD	20	1	5,000	4,330	3,535	2,500	2	24
AWLB-1-820LD	20	1	10,000	8,660	7,071	5,000	2	24
AWLN-1-624LD	24	1	5,000	4,330	3,535	2,500	2	24
AWLB-1-824LD	24	1	10,000	8,660	7,071	5,000	2	24

## Amick Multi-Leg Bridles

version #1-23

### Amick Multi-Leg Bridles

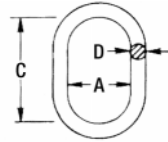
Nylon or Polyester bridle assemblies are useful whenever the load is equipped with permanent lifting attachments. For such applications, bridle assemblies are lightweight, easy-to-use and economical.

The following table shows rated capacities and hardware specifications for two-leg assemblies. Assemblies of one, three or four legs are available upon special request. Additional end fittings can also be supplied. Please consult your distributor for more information.

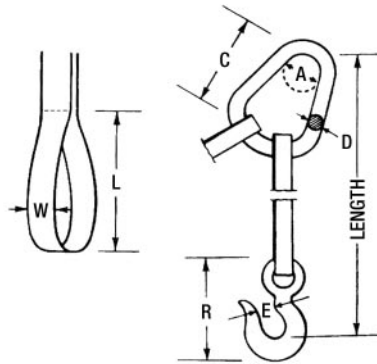
#### How to Order

Stock numbers (from capacity table) are prefixed by code letters to designate bridle attachments. The first letter indicates the leg attachment: P (pear link) or O (oblong link). The next letters indicate the end attachment: SH (safety hook), E (eye), P (pear link) or O (oblong link). For each leg required, a letter is used to designate the end attachment.

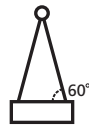
**Example:** PSHSH-1-802x10' = The leg attachment is a pear shaped link, and the end attachment on each of the two legs is a Safety Hook, single ply, two inch wide x 10 ft. length.



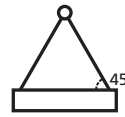
Alloy oblong links available on all assemblies with capacities over 4000 lbs.



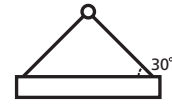
Key letters in drawings refer to the dimensions shown in Table 6-15.



60° Basket



45° Basket



30° Basket

Table 6-20. Amick Multi-Leg Bridles (Rated Capacity in Pounds for 2-Leg Bridle Slings)

Stock Number	Width (in.)	Ply	60°	45°	30°	Pear Link			Alloy Oblong Link			Eye Hoist Hook			Fabric Eye Dimensions (in.)	
						A	C	D	A	C	D	WLL (tons)	Dimensions (in.)		L	W
													E	R		
-1-601 ①	1	1	2,320	2,080	1,700	1	3	1/2	2-1/2	5	1/2	3/4	1-5/16	3-7/32	9	1
-1-801	1	1	3,090	2,770	2,260	1	3	1/2	2-1/2	5	1/2	1	1-1/32	3-21/32	9	1
-2-601	1	2	4,640	4,160	3,400	1-1/4	3-3/4	5/8	2-1/2	5	1/2	1-1/2	1-1/16	4-3/32	9	1
-2-801	1	2	6,180	5,540	4,520	1-1/2	4-1/2	3/4	3	6	5/8	3	1-1/2	5-3/4	9	1
-1-192	1-3/4	1	3,550	3,180	2,600	1-1/4	3-3/4	5/8	2-1/2	5	1/2	1	1-1/32	3-21/32	9	1-3/4
-1-262	1-3/4	1	5,100	4,570	3,740	1-1/2	4-1/2	3/4	3	6	5/8	1-1/2	1-1/16	4-3/32	9	1-3/4
-2-192	1-3/4	2	7,110	6,370	5,210	1-1/2	4-1/2	3/4	2-3/4	5-1/2	3/4	2	1-7/32	4-11/16	9	1-3/4
-2-262	1-3/4	2	10,200	9,150	7,480	2	6	1	2-3/4	5-1/2	3/4	3	1-1/2	5-3/4	9	1-3/4
-1-602	2	1	4,640	4,160	3,400	1-1/4	3-3/4	5/8	2-1/2	5	1/2	1-1/2	1-1/16	4-3/32	9	2
-1-802	2	1	6,180	5,540	4,520	1-1/2	4-1/2	3/4	3	6	5/8	2	1-7/32	4-11/16	9	2
-2-602	2	2	9,280	8,320	6,800	1-3/4	5-1/4	7/8	2-3/4	5-1/2	3/4	3	1-1/2	5-3/4	9	2
-2-802	2	2	12,360	11,080	9,040	2	6	1	4	8	1	5	1-7/8	7-3/8	9	2
-1-603	3	1	6,960	6,240	5,100	1-1/2	4-1/2	3/4	2-3/4	5-1/2	3/4	2	1-7/32	4-11/16	12	1-1/2
-1-803	3	1	9,270	8,310	6,780	1-3/4	5-1/4	7/8	2-3/4	5-1/2	3/4	3	1-1/2	5-3/4	12	1-1/2
-2-603	3	2	13,410	12,020	9,830	2-1/2	7-3/4	1-1/4	4	8	1	5	1-7/8	7-3/8	12	1-1/2
-2-803	3	2	17,860	16,010	13,060	2-1/2	7-3/4	1-1/4	4	8	1	5	1-7/8	7-3/8	12	1-1/2

① Please designate by code, leg and attachments. Other end attachments available. All dimensions in inches.

### Web Shackles & Fittings

#### Sling Saver Web Connector

**Sling Saver, Load Rated, Quenched & Tempered**

- Connects Synthetic Web and Synthetic Round Slings to conventional Crosby hardware including:
  - 320N Eye Hook.
  - Additional Crosby Grade 8 Fittings.
  - Master Links.
  - Rings.
  - Shackles.
- Makes a field assembled bridle quick and easy.
- No cotter pin to snag sling material.
- Durable vinyl cover that:
  - Protects sling at eye.
  - Keeps sling positioned correctly on spool.
- Increased radius of spool gives wider sling bearing surface resulting in an increased area for load distribution, thus:
  - Increasing Synthetic Sling efficiency by at least 15% as compared to standard anchor and chain shackle bows and conventional eye hooks. This allows 100% of the slings rated Working Load Limit to be achieved.
  - Allowing better load distribution on internal fibers.

- All Alloy construction.
- Design Factor of 5 to 1.
- Replacement kit for spool and web cover available.
- Designed for use with Type III (Eye & Eye), Class 7, 2 ply webbing & Synthetic Round Slings. Also accommodates single ply and endless slings.



S-280

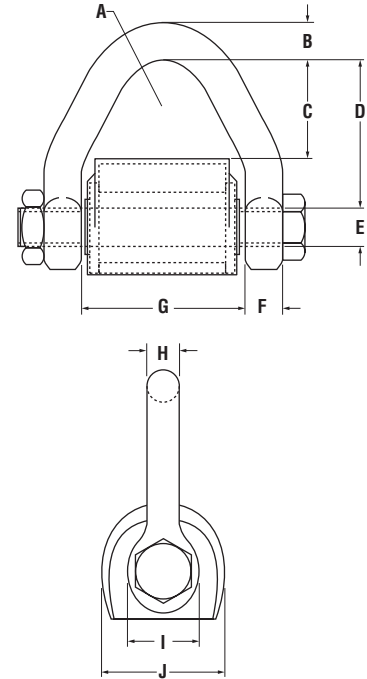


Table 6-21. S-280 Web Connector

Round Sling Size (No.)	Web Slings ①			Working Load Limit (tons) ②	S-280 Stock No.	Weight Each (lbs.)	Dimensions (in.)									
	Webbing Width (in.)	Eye Width (in.)	Ply				A	B	C	D	E	F	G	H	I	J
1 & 2	2	2	2	3-1/4	1021681	1.5	.75	.62	1.63	2.44	.63	.62	2.69	.56	1.19	2.02
3	3	1.5	2	4-1/2	1021690	1.9	.75	.69	1.10	2.01	.75	.69	2.19	.60	1.38	2.34
4	4	2	2	6-1/4	1021700	2.9	.75	.81	1.66	2.56	.88	.75	2.69	.69	1.62	2.46
5 & 6	6	3	2	8-1/2	1021709	5.1	1.00	.94	2.47	3.50	1.00	.88	3.69	.88	1.88	2.84

① Designed for use with Type III, (Eye & Eye), Class 7, 2 Ply web slings.

② Maximum Proof Load is 2-1/2 times the Working Load Limit. Minimum Ultimate strength is 5 times the Working Load Limit.

**Note:** Crosby Sling Saver hardware meets the requirements for minimum stock diameter or thickness, and effective contact width shown in the Recommended Standards Specification for Synthetic Polyester Roundslings by the Web Sling & Tie Down Association. WSTDA-RS1 (revised 2001).

**\*WARNING**

A falling load may cause serious injury or death. Read, understand and follow all instructions and chart information before using web connectors. Before use, tighten bolt first, then tighten nut.

# WEB & SYNTHETIC

Amick Associates, Inc.

## Web Shackles & Fittings

version #1-23

the Crosby group inc.

Made in the U.S.A.

### Sling Saver Fittings

#### Sling Saver, Load Rated, Quenched & Tempered

- Incorporates same ear spread and pin dimensions as conventional Crosby Shackles. Allows easy connection to pad eyes, eye bolts, and lifting lugs.
- Increased radius of bow gives wider sling bearing surface resulting in an increased area for load distribution, thus:
  - Increasing Synthetic Sling efficiency by at least 15% as compared to standard anchor and chain shackle bows and conventional eye hooks. This allows 100% of the slings rated Working Load Limit to be achieved.
  - Allows better load distribution on internal fibers.
- All alloy construction.
- Design factor of 5 to 1.
- Each shackle has a Product Identification Code (PIC) for material traceability along with a Working Load Limit and the name Crosby forged into it.
- Look for the Red Pin®... the mark of genuine Crosby quality.



S-281

**Note:** Web Sling Shackle is designed to connect Synthetic Web Slings and Synthetic Round Slings to eyebolts, pad eyes, and lifting lugs.

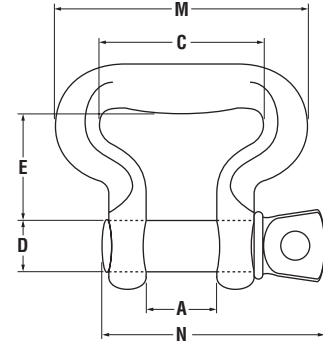


Table 6-22. S-281 Web Connector

Round Sling Size (No.)	Web Slings ①			Working Load Limit (tons) ②	S-281 Stock No.	Weight Each (lbs.)	Dimensions (in.)						
	Webbing Width (in.)	Eye Width (in.)	Ply				A	C	D	E	K	M	N
1 & 2	2	2	2	3-1/4	1021048	1.2	1.06	2.50	.75	1.62	1.22	3.84	3.34
3	3	1.5	2	4-1/2	1021057	1.5	1.25	2.00	.88	1.50	1.41	3.38	3.97
4	4	2	2	6-1/4	1021066	2.5	1.44	2.50	1.00	2.00	1.62	4.22	4.50
5 & 6	6	3	2	8-1/2	1021075	4.3	1.69	3.62	1.13	2.75	1.84	5.64	5.13

① Designed for use with Type III, (Eye & Eye), Class 7, 2 Ply web slings.

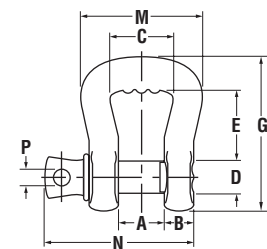
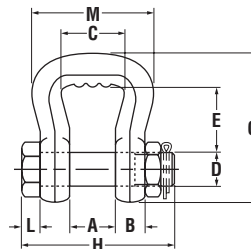
② Maximum Proof Load is 2-1/2 times the Working Load Limit. Minimum Ultimate Strength is 5 times the Working Load Limit.

**Note:** Crosby Sling Saver hardware meets the requirements for minimum stock diameter or thickness, and effective contact width shown in the Recommended Standards Specification for Synthetic Polyester Roundslings by the Web Sling & Tie Down Association. WSTDA-RS1 (revised 2001).

### Sling Saver Web Sling Shackles

**Sling Saver, Fatigue Rated, Load Rated, Quenched & Tempered**

- Designed with non-slip surface that:
  - Eliminates bunching effect caused by traditional shackles.
  - Reduces sling tendency to slide.
- Shackles available in size 3-1/4 to 50 tons.
- Increased radius of bow gives wider sling bearing surface resulting in an increased area for load distribution, thus:
  - Increasing Synthetic Sling efficiency by at least 15% as compared to standard anchor and chain shackle bows and conventional hooks. This allows 100% of the slings rated Working Load Limit to be achieved.
  - Allows better load distribution on internal fibers.
- Design factor of 5 to 1.
- Shackles available in both a screw pin and bolt and cotter pin configuration.
- Bolt (pin) has a larger diameter that provides better load distribution.
- Look for the Red Pin®... the mark of genuine Crosby quality.
- Each shackle has a Product Identification Code (PIC) for material traceability along with a Working Load Limit and the name Crosby forged into it.
- All alloy construction.



**S-252**  
**Bolt-Type Sling Shackle**

**S-253**  
**Screw Pin Sling Shackle**

**Table 6-23. S-252 Bolt Type Sling Shackle**

Web Sling Eye Width (in.)	Round Sling Size (No.)	Working Load Limit (tons) ①	S-252 Stock No.	Weight Each (lbs.)	Dimensions (in.)											
					A	B	C	D	E	F	G	H	J	K	L	M
1	1 & 2	3-1/4	1020485	1.4	.88	.62	1.38	.75	1.50	.44	3.38	3.68	1.12	1.50	.75	2.69
1.5	3 & 4	6-1/2	1020496	2.4	1.25	.75	1.75	.88	1.88	.50	4.15	4.25	1.31	1.81	1.00	3.38
2	5 & 6	8-3/4	1020507	4.1	1.38	.88	2.25	1.00	2.81	.56	5.50	4.72	1.50	2.09	1.12	4.19
3	7 & 8	12-1/2	1020518	8.0	1.62	1.12	3.25	1.25	3.06	.75	6.34	5.88	1.88	2.62	1.38	5.62
4	9 & 10	20-1/2	1020529	16.9	2.12	1.38	4.50	1.50	5.75	.88	9.75	7.19	2.25	3.12	1.75	7.50
5	11 & 12	35	1020540	35.0	2.50	1.75	5.50	2.00	6.34	1.12	11.50	9.31	3.00	4.19	2.25	9.19
6	13	50	1020551	57.5	3.00	2.12	6.50	2.25	7.70	1.25	13.75	10.38	3.38	4.75	2.75	11.00

① Maximum Proof Load is 2.5 times the Working Load Limit. Minimum Ultimate Strength is 5 times the Working Load Limit.

**Table 6-24. S-253 Screw Pin Sling Shackle**

Web Sling Eye Width (in.)	Round Sling Size (No.)	Working Load Limit (tons) ①	S-253 Stock No.	Weight Each (lbs.)	Dimensions (in.)											
					A	B	C	D	E	G	K	L	M	N	P	R
1	1 & 2	3-1/4	1020575	1.4	.88	.62	1.38	.75	1.50	3.38	1.50	.75	2.69	3.22	.44	1.00
1.5	3 & 4	6-1/2	1020584	2.2	1.25	.75	1.75	.88	1.88	4.15	1.81	1.00	3.38	4.03	.50	1.19
2	5 & 6	8-3/4	1020593	3.8	1.38	.88	2.25	1.00	2.81	5.50	2.09	1.12	4.19	4.50	.50	1.44
3	7 & 8	12-1/2	1020602	7.3	1.62	1.12	3.25	1.25	3.06	6.34	2.62	1.38	5.62	5.59	.62	1.81
4	9 & 10	20-1/2	1020611	15.2	2.12	1.38	4.50	1.50	5.75	9.75	3.12	1.75	7.50	6.88	.75	2.13
5	11 & 12	35	1020620	30.8	2.50	1.75	5.50	2.00	6.34	11.50	4.19	2.25	9.19	8.66	1.00	2.88
6	13	50	1020629	52.0	3.00	2.12	6.50	2.25	7.70	13.75	4.75	2.75	11.00	10.22	1.22	3.19

① Maximum Proof Load is 2.5 times the Working Load Limit. Minimum Ultimate Strength is 5 times the Working Load Limit.

# WEB & SYNTHETIC

Amick Associates, Inc.

## Web Shackles & Fittings

version #1-23



Made in the U.S.A.

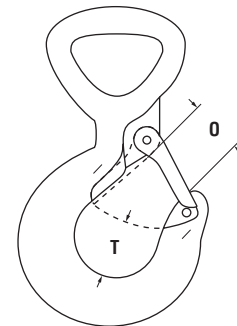
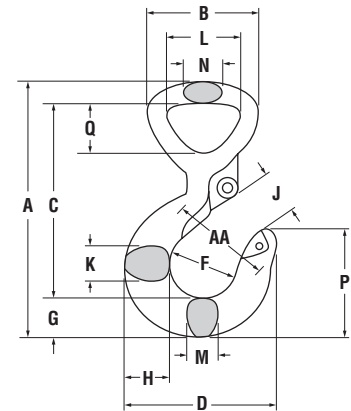
### Sling Saver Web Sling Hooks

**Sling Saver, Fatigue Rated, Load Rated, Quenched & Tempered, QUIC-CHECK**

- Originally designed for 2-Ply Web slings, the Crosby Web Sling hook can also be used with Round Slings as long as the Working Load Limit ratings are compatible. The new hook incorporates the following features:
- Eye is designed with a wide beam surface which:
  - Eliminates bunching effects.
  - Reduces sling tendency to slide.
  - Allows a better load distribution on internal fibers.
- Each hook has a Product Identification Code (PIC) for material traceability along with a working load limit and the name Crosby forged into it.
- All hooks feature Crosby's patented QUIC-CHECK® indicators.
- Hook capacities available: 1-1/2, 3 and 5 tons.
- Hook Web Sling Eye width available: 1", 2" and 3".
- All Alloy construction.
- Design factor of 5 to 1.
- Fatigue rated to 20,000 cycles at 1-1/2 times the Working Load Limit.



**WS-320A  
Web Sling Hook**



**Table 6-25. WS-320A Web Sling Hooks**

Web Sling Eye Width (in.)	Round Sling Size (No.)	Working Load Limit (tons) ①	WS-320A Stock No.	WSL-320A with Latch	Weight Each (lbs.)	Hook I.D. Code	S-4320 Rep. Latch
1	1	1-1/2	1022701	1022706	1.10	FA	1096374
2	2	3	1022712	1022717	2.86	HA	1096468
3	3	5	1022723	1022728	6.60	IA	1096515

① Maximum Proof Load is 2-1/2 times the Working Load Limit. Average straightening load (ultimate load) is 5 times the Working Load Limit.

**Table 6-25. WS-320A Web Sling Hooks (Continued)**

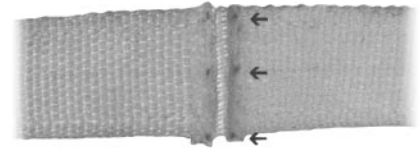
Web Sling Eye Width (in.)	Dimensions (in.)																
	A	B	C	D	F	G	H	J	K	L	M	N	O	P	Q	T	AA
1	5.25	2.26	3.98	3.11	1.38	.84	.94	.93	.71	1.50	.63	.75	.91	2.24	1.01	.98	2.00
2	7.11	3.66	5.31	3.97	1.63	1.13	1.32	1.13	.94	2.50	.85	1.13	1.09	2.82	1.69	1.16	2.00
3	9.33	5.13	7.06	4.81	2.00	1.44	1.63	1.47	1.31	3.75	1.13	1.63	1.36	3.51	2.59	1.53	2.50

**Note:** Crosby Sling Saver hardware meets the requirements for minimum stock diameter or thickness, and effective contact width shown in the Recommended Standards Specification for Synthetic Polyester Roundslings by the Web Sling & Tie Down Association. WSTDA-RS1 (revised 2001).

## Optional Pads & Wear Protection

Only two of the 10 sling types offered in this catalog include wear protection as standard features — Types 6 and 7. Therefore, if slings other than these are to be used under damaging conditions, wear pads should be specified at time of ordering to assure an economic and safe useful life.

Cordura Nylon and Polyester material — similar fabrics designed especially for this application — will be used as padding unless another material is specified at time of ordering. Pads are also offered in chrome leather, in Tanera synthetic leather (more economical and stiffer than chrome leather), or in the same material as the sling body.



*\*Red Wear Warning Yarns  
Featured in Most Slings*

### Seven Types of Wear Pads are Offered:



- 1. Regular** pads are an extra layer of material sewn at wear points on either or both sides of the sling body or eyes. Multiple layers are available on request.



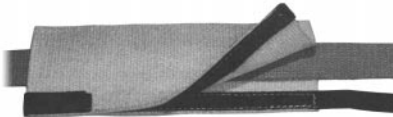
- 2. Edge Guard** pads are sewn along edges of the sling body wherever protection is desired.



- 3. Sleeve or Tube** pads protect both sides and may be shifted along the sling. This type offers the advantage of remaining stationary as the sling stretches while the load is being lifted.



- 4. Wrap** padding is similar to sleeve, but is sewn to the sling body and protects edges as well as lifting surface.



- 5. Velcro Sleeve** pads are made of nylon webbing with Velcro edge for quick removal from slings such as chain, wire rope and nylon.



- 6. PVC Sliding Pad** edge protectors can be easily moved to various bearing points.

- 7. Felt Light & Heavy Duty:** strong cut resistant with flexibility. Sliding and attached wear pads available.

Where a unique padding arrangement is desired, a sketch should accompany the order. Wear padding must also be specified for sling eyes, when desired, on the order.

### \*WARNING

All Amick synthetic web slings are equipped with red warning yarns. When these yarns appear, the sling shall be discarded.

# WEB & SYNTHETIC

Amick Associates, Inc.

version #1-23

## Amick Load Snugger Tie Downs

### Amick Load Snugger Tie Downs

#### Web Cargo Control Binder with Ratchet Action Buckle

**Two Load Ratings: 5,000 and 10,000 lb.**  
**Rated capacity with 2-inch webbing.**  
**Additional sizes available.**

The Amick Load Snugger Tie Down provides a fast, one-hand way to snug down loads — on pallets, in vans and trucks, baggage compartments, shipping containers and aircraft. Tension adjustment is infinite. Locks securely by pressing down on the ratchet handle, releases just as easily.

Amick Load Snugger Tie Downs are fabricated to customer's order in any practical length, as straight assemblies (Type ALS-A) or 2-piece devices with special metal fixtures or sewn eyes at the ends to attach to pallets, trucks, etc. Sliding fabric sleeves and corner protectors are available as optional extras.

Amick Load Snugger Tie Downs are fabricated of tough, pliable industrial webbing with all cut ends heat sealed to prevent fraying and sewn with precisely engineered stitch patterns. Ratchet buckle and metal end fittings are plated to resist corrosion.



**F Flat Hook**

6

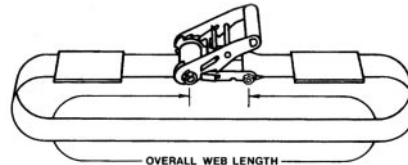
#### Type ALS-B

These 2-piece devices have metal fittings or eyes sewn at the ends of two pieces of webbing, the shorter of which is sewn to the ratchet head. The variable length piece is heat sealed to prevent fraying, for easy insertion into the ratchet spool. Offered in any practical length (between bearing points of eyes or hooks), plus 6 inches for insertion into ratchet. **Consult your distributor for other end fittings available.**

**Sliding Sleeve** type wear pads, ratchet pads corner protectors for protection of webbing available on all types.

#### Type ALS-A

One end of webbing is sewn to the ratchet head, the other is free for passing around the load or through narrow openings and inserting into the ratchet spool. Fabricated to any practical web length, plus 6 inches additional length for end hold.



**Type ALS-A**

#### Other Available Fittings for 2-Inch Tie Downs



**Flat Hook**



**Triangle**



**Stamped Snap Hook**



**Twisted Snap Hook**



**Forged Snap Hook**



**D-Ring**



**Narrow Wire U-Hook**



**Hook & Keeper**

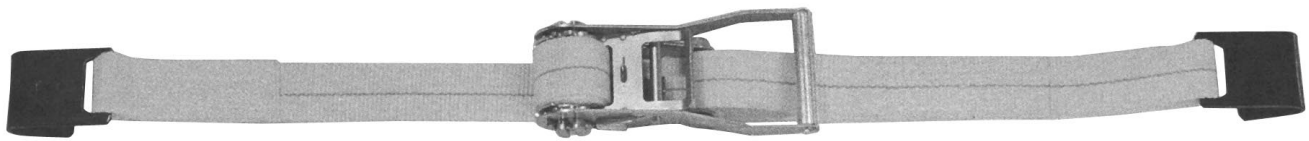
### Amick 3-Inch & 4-Inch Truck Tie Down Assemblies Polyester Webbing E-Track Assemblies

- Fabricated to customer order.
- Fit standard 3-inch and 4-inch winches.
- Meet or exceed California and Federal regulations.
- Corner protectors, sliding sleeves available.

Polyester webbing is soft, pliable and non-abrasive, makes an ideal tie down strap for securing cargo on flatbed trucks and trailers. Lighter and easier to handle than chain load binders...longer lasting and stronger than

elastic tension bands...adjustable in length to accommodate varying size loads. Polyester is also low-stretch (approximately 3% at Rated Capacity). Strength is not affected by moisture. All cut ends are heat sealed to prevent fraying.

Available with four Standard End Treatments in two Rated Capacities (3-inch and 4-inch webbing).



**Flat Hook**

#### E-Track Assemblies Cam Buckle



**E-Track Fitting**



**Slat Hook**



**Fixed Winch**

Designed for fixed mounting, for use with loose end (pull-thru) straps. Rugged 3/8" steel frame, 5/8" ratchet and pawl, hardened steel pawl pin, 4" slotted mandrel. 8-1/8" L, 5-1/2" H, 3-1/2" W. Models available to store 30 ft. or 36 ft. of webbing.



**E-Track Fitting (Spring Loaded)**



**RTJ Cluster Hooks  
Auto Tie Down**



**Horizontal E-Track  
10 ft. sections primed  
(Vertical E-Track also available)**

**Not Pictured:** Sliding winches designed to slide along winch track. User must specify manufacturer of winch track.

**Note:** Other winches and winch track available. Contact your distributor for information.

### Nylon Inspection & Repair

Amick associates issues all new nylon slings to customers' specifications. Amick Associates also can repair all your existing nylon web slings.

\*Amick Associates also provides on-site inspection of your nylon slings.

**Sliding Sleeve** type wear pads and metal corner protectors available upon request.

#### \*WARNING

When subjected to loading greater than the Rated Capacity, permanent loss of strength may result. All nylon web slings need to be inspected before each use.

# HANDS-FREE LOAD POSITIONERS

---

## General Information

Help Prevent Injuries  
Amick Round Tubular Web Type  
Flat Web Type  
Steel Rod Type  
Amick Quality



# HANDS-FREE LOAD POSITIONERS

Amick Associates, Inc.

version #2-04

## General Information

### General Information

#### Help Prevent Injuries

Amick Associates has a complete line of hands-free load positioners. These nylon web and round steel bar hand tools can prevent pinching and other hand and arm injuries in the workplace. Workers can stay away from the load that is being lifted but still be in control of maneuvering it into the position required with standard or custom made *Amick Hands-Free Load Positioners*.

#### Amick Round Tubular Web Type

A variety of *Amick Round Tubular Web Type Hands-Free Load Positioners* can be manufactured to fit your chain or wire rope slings. They can easily be attached to the lifting sling. These round nylon Velcro® closed positioners have strong PVC handles and can be made to fit your sling size. They will slide easily into different positions or can be positioned at a certain point on your chain sling with our easy on/off link attachment system.

#### Flat Web Type

These 1" wide nylon *Flat Web Type Hands-Free Load Positioners* are an excellent choice for positioning wire rope slings and nylon web slings around any load to be lifted without encountering dangerous pinch points. They can be made in lengths from 6" to 36" or longer. These high quality wear-resistant positioners are made with a small loop on one end with a Velcro loop closer and pancaked with heavy duty Velcro on the full length of the webbing. Stiffener rods can be safely added to help with more difficult load positioning. These rigid web positioners can easily push and pull the sling into the proper position. Let an Amick representative show you the different styles and sizes available.

#### Steel Rod Type

These high strength pulling and pushing *Shepherd Style Load Positioners* are made in a variety of designs and sizes. We use 3/8" steel rod and can custom make these *Steel Rod Load Positioners* for your particular load applications. These load positioners are painted Caution Yellow and come with a choice of three different handles. The steel loop handle, the round wooden handle, or the vinyl bicycle-style handle can all help in the safe positioning of any sling or load without workers' hands close to dangerous pinching areas. This allows them to stay away from the load being lifted and still be able to position it where you need it. Let an Amick representative show you the many different styles and lengths available.

#### Amick Quality

If you want to eliminate pinch-point accidents, high quality *Amick Hands-Free Load Positioners* are the way to get the sling and the load into position without putting any part of a person's body in harm's way.

# PLATE LIFTING CLAMPS

---

## **Safety Clamp®**

### **Plate Lifting Clamp Products**

Models AVL and VL

Models AVL and VL with Auxiliary Lock

Model VL-SJ

Model HL — Lock

Model HLW

## **RENFROE® Plate Lifting Clamp Products**

Model S

Model TL and TLA

Model FR

Model JPA

Model NM

Model SCP and SCPA

Model M

Model WHSR

Model SEA

"Little Brute" Model LBS

## **Definitions**

---



# PLATE LIFTING CLAMPS

Amick Associates, Inc.

Safety Clamp® Plate Lifting Clamp Products

version #2-04

Made in the U.S.A. 

## Safety Clamp® Plate Lifting Clamp Products

### Models AVL and VL

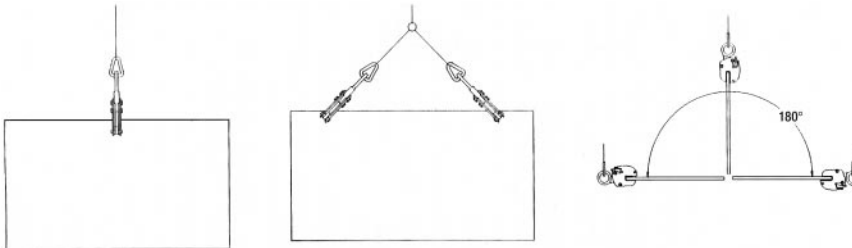
#### Locking Clamp

Horizontal to Vertical – 180°

1/2 through 20 Tons Rated Lift Capacities

#### Features:

- **Horizontal to Vertical Lift**
  - Capable of turning a single steel plate from horizontal to vertical to horizontal through a 180° arc.
- **Locks Open and Closed**
  - Locks open to facilitate loading and unloading clamp.
  - Locks closed onto material for a more secure fit.
- **Gripping Cams**
  - 2 through 20 ton lift capacities incorporate dual gripping cams.
  - Increases grip on load for a more secure lift.
- **Self-Aligning Pivoting Die**
  - Increased surface contact between load and clamp.
- **Wide Jaw Openings**
  - Wider range within rated lift capacity.
- **High Strength Shock-Resistant Steel**
  - Provides for longer clamp life.
- **Working Parts Enclosed**
  - Working parts remain inside the body in the “locked closed” position and the “locked open” position.
  - Protects parts for longer use.



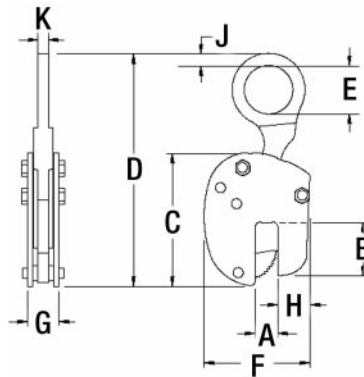
**Table 8-1. Models AVL and VL (Dimensions in Inches)**

Dimensions	1/2 & 1 Ton		2 Ton		3 Ton		4 Ton			6 Ton		
	AVL	VL	VL	VL	VL	VL	VL	VL	VL	VL	VL	VL
A	0 - 7/8	0 - 1-3/8	0 - 1-5/8	1-1/2 - 2-3/4	0 - 1-5/8	1-1/2 - 2-3/4	0 - 2-1/8	2 - 3-3/4	3-3/4 - 5-1/2	0 - 2-1/8	2 - 3-3/4	3-3/4 - 5-1/2
B	2-3/4	2-3/4	4-1/8	4-1/8	4-1/8	4-1/8	4-5/8	4-5/8	4-5/8	4-5/8	4-5/8	4-5/8
C	6-7/8	6-7/8	9	9	9	9	11-1/4	11-1/4	11-1/4	11-1/4	11-1/4	11-1/4
D Max.	11-3/4	12	16-1/4	16-1/4	16	16	18	18	18	18	18	18
E	2-1/2	2-1/2	3-1/2	3-1/2	3-1/2	3-1/2	4	4	4	4	4	4
F	5-3/8	5-1/2	8	9-1/8	8	9-1/8	9-1/2	11-1/8	13	9-1/2	11-1/8	13
G	2-5/8	2-5/8	4	4	4	4	5	5	5	5	5	5
H	1-1/2	1-1/2	2-3/8	2-3/8	2-3/8	2-3/8	2-1/2	2-1/2	2-1/2	2-1/2	2-1/2	2-1/2
J	5/8	5/8	7/8	7/8	7/8	7/8	1	1	1	1	1	1
K	1/2	1/2	3/4	3/4	3/4	3/4	3/4	3/4	3/4	3/4	3/4	3/4
Wt. (lbs.)	11	11	23	27	27	30	42	47	50	50	54	57

**Table 8-1. (Continued) Models AVL and VL (Dimensions in Inches)**

Dimensions	8 Ton			10 Ton			12 Ton			20 Ton		
	VL	VL	VL	VL	VL	VL	VL	VL	VL	VL	VL	VL
A	0 - 2-5/8	2-1/2 - 4-1/2	4-1/2 - 6-1/2	0 - 2-5/8	2-1/2 - 4-1/2	4-1/2 - 6-1/2	1/2 - 3-1/8	3 - 5-1/4	5 - 7-1/4	1/2 - 4-1/4	4 - 7	7 - 10
B	5-1/4	5-1/4	5-1/4	5-1/4	5-1/4	5-1/4	6-1/2	6-1/2	6-1/2	8-3/8	8-3/8	8-3/8
C	12-7/8	12-7/8	12-7/8	12-7/8	12-7/8	12-7/8	16-3/4	16-3/4	16-3/4	23	23	23
D Max.	22-3/8	22-3/8	22-3/8	22-3/8	22-3/8	22-3/8	27-3/4	27-3/4	27-3/4	36-3/8	36-3/8	36-3/8
E	4-1/2	4-1/2	4-1/2	4-1/2	4-1/2	4-1/2	4-7/8	4-7/8	4-7/8	5-5/8	5-5/8	5-5/8
F	10-1/2	12-3/8	14-3/8	10-1/2	12-3/8	14-3/8	12-1/4	14-3/8	16-3/8	17	20	22-5/8
G	5-3/4	5-3/4	5-3/4	5-3/4	5-3/4	5-3/4	6-3/4	6-3/4	6-3/4	8-1/4	8-1/4	8-1/4
H	3-1/4	3-1/4	3-1/4	3-1/4	3-1/4	3-1/4	3-1/4	3-1/4	3-1/4	4-1/4	4-1/4	4-1/4
J	1-1/4	1-1/4	1-1/4	1-1/4	1-1/4	1-1/4	1-5/8	1-5/8	1-5/8	2	2	2
K	1	1	1	1	1	1	1	1	1	1-1/2	1-1/2	1-1/2
Wt. (lbs.)	65	70	75	75	80	90	92	101	112	259	292	322

**Note:** Specifications are subject to change without notice.



# PLATE LIFTING CLAMPS

Amick Associates, Inc.

Safety Clamp® Plate Lifting Clamp Products

version #2-04

Made in the U.S.A. 

## Models AVL and VL with Auxiliary Lock

### Locking Clamp

Horizontal to Vertical – 180°

1/2 through 12 Ton Rated Lift Capabilities

### Features:

#### ■ Auxiliary Lock

- Provides for a double-locking mechanism in the “locks closed” position.

#### ■ Horizontal to Vertical Lift

- Capable of turning a single steel plate from horizontal to vertical to horizontal through a 180° arc.

#### ■ Locks Open and Closed

- Locks open to facilitate loading and unloading clamp.
- Locks closed onto material for a more secure lift.

#### ■ Gripping Cams

- 2 through 12 ton lift capacities incorporate dual gripping cams.
- Increase grip on load for a more secure lift.

#### ■ Self-Aligning Pivoting Die

- Increased surface contact between load and clamp.

#### ■ Wide Jaw Openings

- Wider range within rated lift capacity.

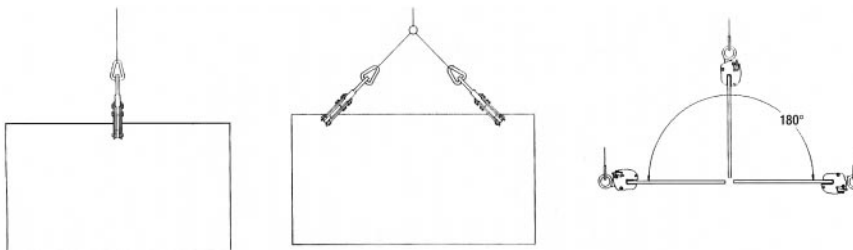
#### ■ High Strength Shock-Resistant Steel

- Provides for longer clamp life.

#### ■ Working Parts Enclosed

- Working parts remain inside the body in the “locked closed” position and the “locked open” position.
- Protects parts for longer use.

#### ■ Also available with universal shackle.



# PLATE LIFTING CLAMPS

Safety Clamp® Plate Lifting Clamp Products

Made in the U.S.A. 

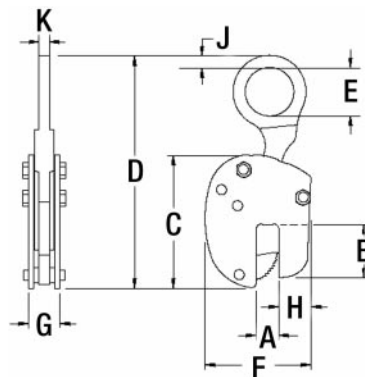
**Table 8-2. Models AVL and VL with Auxiliary Lock (Dimensions in Inches)**

Dimensions	1/2 & 1 Ton AVL		1/2 & 1 Ton VL		2 Ton VL		3 Ton VL		4 Ton VL			6 Ton VL			
A	0 - 7/8	0 - 1-3/8	0 - 1-5/8	1-1/2 - 2-3/4	0 - 1-5/8	1/1/2 - 2-3/4	0 - 2-1/8	2 - 3-3/4	3-3/4 - 5-1/2	0 - 2-1/8	2 - 3-3/4	3-3/4 - 5-1/2	0 - 2-1/8	2 - 3-3/4	3-3/4 - 5-1/2
B	2-3/4	2-3/4	4-1/8	4-1/8	4-1/8	4-1/8	4-5/8	4-5/8	4-5/8	4-5/8	4-5/8	4-5/8	4-5/8	4-5/8	4-5/8
C	6-7/8	6-7/8	9	9	9	9	11-1/4	11-1/4	11-1/4	11-1/4	11-1/4	11-1/4	11-1/4	11-1/4	11-1/4
D Max.	11-3/4	12	16-1/4	16-1/4	16	16	18	18	18	18	18	18	18	18	18
E	2-1/2	2-1/2	3-1/2	3-1/2	3-1/2	3-1/2	4	4	4	4	4	4	4	4	4
F	5-3/8	5-1/2	8	9-1/8	8	9-1/8	9-1/2	11-1/8	13	9-1/2	11-1/8	13	9-1/2	11-1/8	13
G	2-7/8	2-7/8	4-1/8	4-1/8	4-1/8	4-1/8	5	5	5	5	5	5	5	5	5
H	1-1/2	1-1/2	2-3/8	2-3/8	2-3/8	2-3/8	2-1/2	2-1/2	2-1/2	2-1/2	2-1/2	2-1/2	2-1/2	2-1/2	2-1/2
J	5/8	5/8	7/8	7/8	7/8	7/8	1	1	1	1	1	1	1	1	1
K	1/2	1/2	3/4	3/4	3/4	3/4	3/4	3/4	3/4	3/4	3/4	3/4	3/4	3/4	3/4
Wt. (lbs.)	11	11	23	27	27	30	42	47	50	50	54	57	50	54	57

**Table 8-2. (Continued) Models AVL and VL with Auxiliary Lock (Dimensions in Inches)**

Dimensions	8 Ton VL			10 Ton VL			12 Ton VL		
A	0 - 2-5/8	2-1/2 - 4-1/2	4-1/2 - 6-1/2	0 - 2-5/8	2-1/2 - 4-1/2	4-1/2 - 6-1/2	1/2 - 3-1/8	3 - 5-1/4	5 - 7-1/4
B	5-1/4	5-1/4	5-1/4	5-1/4	5-1/4	5-1/4	6-1/2	6-1/2	6-1/2
C	12-7/8	12-7/8	12-7/8	12-7/8	12-7/8	12-7/8	16-3/4	16-3/4	16-3/4
D Max.	22-3/8	22-3/8	22-3/8	22-3/8	22-3/8	22-3/8	27-3/4	27-3/4	27-3/4
E	4-1/2	4-1/2	4-1/2	4-1/2	4-1/2	4-1/2	4-7/8	4-7/8	4-7/8
F	10-1/2	12-3/8	14-3/8	10-1/2	12-3/8	14-3/8	12-1/4	14-3/8	16-3/8
G	5-3/4	5-3/4	5-3/4	5-3/4	5-3/4	5-3/4	6-3/4	6-3/4	6-3/4
H	3-1/4	3-1/4	3-1/4	3-1/4	3-1/4	3-1/4	3-1/4	3-1/4	3-1/4
J	1-1/4	1-1/4	1-1/4	1-1/4	1-1/4	1-1/4	1-5/8	1-5/8	1-5/8
K	1	1	1	1	1	1	1	1	1
Wt. (lbs.)	65	70	75	75	80	90	92	101	112

**Note:** Specifications are subject to change without notice.



# PLATE LIFTING CLAMPS

Amick Associates, Inc.

Safety Clamp® Plate Lifting Clamp Products

version #2-04

Made in the U.S.A. 

## Model VL-SJ

**Locking Clamp**  
**Horizontal to Vertical**  
**1/2, 1 and 2 Ton Rated Lift Capacities**

### Features:

- **New Lighter Weight** — Designed to give you that "Big Bite" lift without a big clamp.
- **Horizontal to Vertical Lift**
  - Capable of turning a single steel plate from horizontal to vertical to horizontal through a 180° arc.
- **Locks Open and Closed**
  - Locks open to facilitate loading and unloading clamp.
  - Locks closed onto material for a more secure lift.
- **Rated for 420 Brinell Surface Hardness**
  - Gripping cam and gripping die are rated to lift material with a surface hardness up to 420 Brinell.
  - Single gripping cam on all capacities.
  - Gripping die is self-aligning — increased surface contact.
- **High Strength Shock resistant Steel**
  - Provides for longer clamp life.

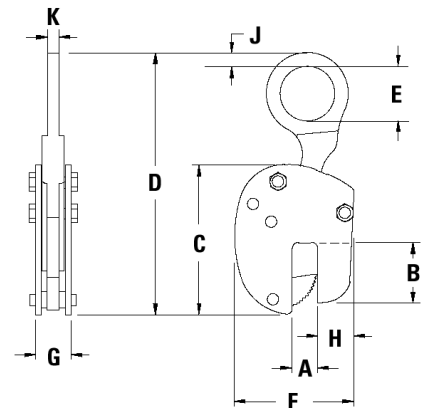
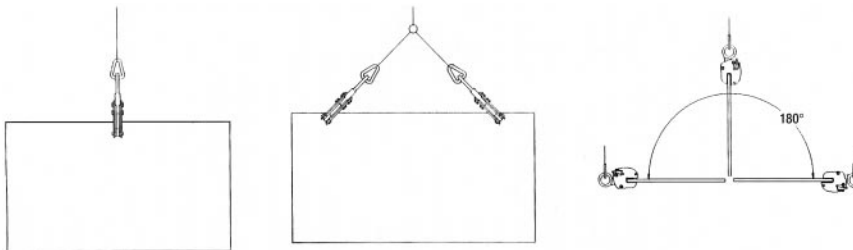


Table 8-3. Specifications (Inches) — Model VL-SJ

Dimension	1/2 Ton	1 Ton	2 Ton
A	0 – 7/8	0 – 7/8	0 – 1
B	2-1/8	2-1/8	2-3/8
C	5-5/8	5-5/8	6-7/8
D Max.	8-5/8	8-5/8	11-1/4
E	1-1/2	1-1/2	2-1/4
F	5-1/8	5-1/8	5-5/8
G	2-5/8	2-5/8	3
H	1-5/16	1-5/16	1-5/8
J	1/2	1/2	5/8
K	1/2	1/2	1/2
Wt. (lbs.)	5	6	10

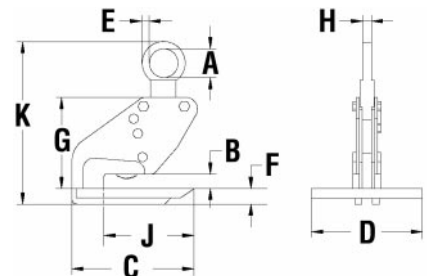


## Model HL — Lock

**Locking Clamp**  
**Horizontal Lift Only**  
**2, 4, 6 and 8 Ton Rated Lift Capacities Per Pair**

### Features:

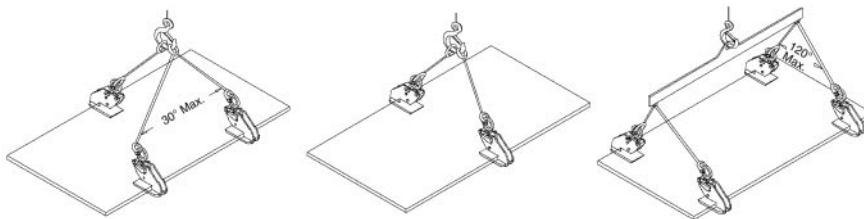
- **Horizontal Lifting Clamp**
  - Used in pairs, sets of pairs, or in tripod arrangement to lift and transfer plate in a horizontal position only.
- **Locks Closed Only**
  - Locks closed onto material for a more secure fit.
  - Easier to handle than a nonlocking clamp.
- **Gripping Cams**
  - Serrated gripping cams clamp onto the plate for a more secure lift.
  - 4 through 8 ton lift capacities per pair incorporate dual gripping cams.
  - Also available with smooth gripping surface of bronze or stainless steel for handling polished metals.
- **Working Parts Enclosed**
  - Working parts remain inside the body in the “locked closed” position and when opening the clamp.
  - Protects parts for longer use.



**Table 8-4. Specifications (Inches) — Model HL — Lock**

Dimension	2 Ton Per Pair	4 Ton Per Pair	6 Ton Per Pair	8 Ton Per Pair
A	2	2-1/2	2-1/2	2-3/4
B	0 – 1	0 – 1-1/2	0 – 1-1/2	0 – 2
C	7-7/8	9-3/8	9-3/8	10-3/4
D	4	5	5	7-1/4
E	1/2	3/4	3/4	1
F	1	1-1/8	1-1/4	1-5/8
G	5-7/16	8-1/4	8-1/4	10-1/4
H	5/8	3/4	3/4	1
J	4-3/4	6-1/4	6-1/4	7
K Max.	10-1/4	14-1/2	14-1/2	18-1/8
Wt. (lbs.)	26/pair	56/pair	60/pair	92/pair

**Note:** Specifications are subject to change without notice.



# PLATE LIFTING CLAMPS

Amick Associates, Inc.

Safety Clamp® Plate Lifting Clamp Products

version #2-04

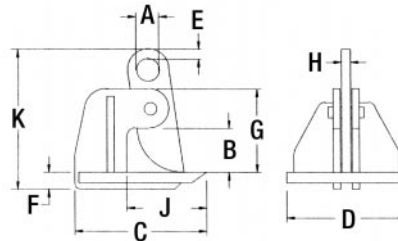
Made in the U.S.A. 

## Model HLW

**Non-locking Clamp**  
Horizontal Lift Only  
3, 6 and 8 Ton Rated Lift Capacities Per Pair

### Features:

- **Horizontal Lifting Clamp**
  - Used in pairs, sets of pairs, or in tripod arrangement to lift and transfer plate in a horizontal position only.
- **Non-Locking**
- **Wide Jaw Openings**
  - Extra wide jaw openings allow for better unloading and transporting of stacked horizontal plates.
- **Gripping Cams**
  - Serrated gripping cam clamps onto the plate for a more secure lift.
  - Also available with smooth gripping surface of bronze or stainless steel for handling polished metals.
  - Dual cam Model HLDW clamps are also available.



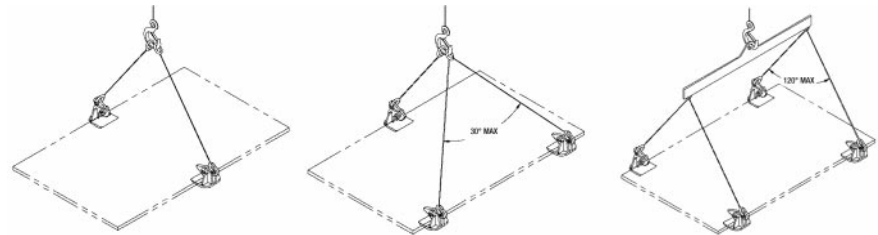
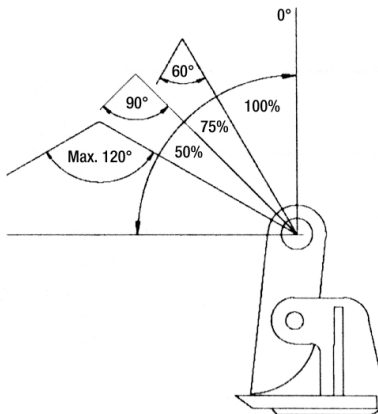
**Table 8-6. Model HLW (Dimensions in Inches)**

Dimensions	3 Ton (Pair)	6 Ton (Pair)	8 Ton (Pair)
A	1-1/2	1-1/2	2-1/4
B	0-6	0-6	0-6
C	11-3/8	11-3/8	12-3/4
D	8	8	8
E	7/8	7/8	1-1/4
F	1-1/8	1-1/4	1-5/8
G	9	9	9-1/2
H	3/4	3/4	1
J	7-3/4	7-3/4	8-1/4
K Max. Wt. (lbs.)	15-5/8 90/Pair	15-3/4 110/Pair	18-3/8 162/Pair

**Note:** Specifications are subject to change without notice.

**Table 8-5. As top sling angle increases, the clamp's rated capacity decreases.**

Top Sling Angle	Rated Capacity
0 – 60°	100%
61 – 90°	75%
91 – 120°	50%



## RENFROE® Plate Lifting Clamp Products

**Table 8-7. Model S – Vertical Lifting, Locking – Specifications (Inches)**

Rated Capacity (tons)	Plate Thickness ①	Weight (lbs.)
2	0 – 1	31
	3/4 – 1-1/2	32
4	0 – 1-1/4	41
	1 – 2	43
8	0 – 1-1/2	70
	1 – 2	73
12	0 – 2-1/2	138
	1/2 – 3	140
20	1/2 – 3	265
	3 – 5	294
50	1/2 – 3	470
100	1/2 – 3	1350

① Available in other plate thicknesses for any of the above rated capacities.

**Table 8-8. Model TL and TLA – Vertical Lifting, Locking – Specifications (Inches)**

Rated Capacity ①	Plate Thickness ①	Weight (lbs.)
1/2	0 – 5/8	9
	1/2 – 1	10
1	0 – 3/4	14
	1/2 – 1	15
2	0 – 1	32
	3/4 – 1-1/2	33
4	3/16 – 1-1/4	35
	1 – 2	37
6	1/4 – 1-3/8	48
	1 – 2-1/8	51
8	3/8 – 1-1/2	72
	1 – 2-1/8	74
12	1/2 – 2-1/2	146
	2 – 4	151

① Other capacities and plate thicknesses available upon request.

**Table 8-9. Model FR – Vertical Lifting, Locking – Specifications (Inches)**

Rated Capacity (tons)	Plate Thickness ①	Weight (lbs.)
1/2	0 – 3/4	7
	1/2 – 1	8
1	0 – 3/4	14
	1/2 – 1	15
2	0 – 1	21
	3/4 – 1-1/2	22
3	0 – 1-1/4	30
	3/4 – 1-1/2	31

① Available in other plate thicknesses for any of the above rated capacities.



Model S



Model TL



Model TLA



Model FR

# PLATE LIFTING CLAMPS

Amick Associates, Inc.

## RENFROE® Plate Lifting Clamp Products

version #2-04

Made in the U.S.A. 

**Table 8-10. Model JPA – Vertical Lifting, Locking – Specifications (Inches)**

Rated Capacity <sup>①</sup> (tons)	Plate Thickness <sup>①</sup>	Weight (lbs.)
1/2	0 – 1/2 1/2 – 1	12
1	0 – 3/4 1/2 – 1	20
2	0 – 1 3/4 – 1-1/2	40
4	3/16 – 1-1/4 1 – 2	50
6	1/4 – 1-3/8 1 – 2-1/8	72
8	3/8 – 1-1/2 1 – 2-1/8	93

<sup>①</sup> Other capacities and plate thicknesses available upon request.



**Model JPA**



**Model NM**



**Model SCP**



**Model SCPA**

**Table 8-11. Model NM – Locking, Screw, Non-Marring – Specifications (Inches)**

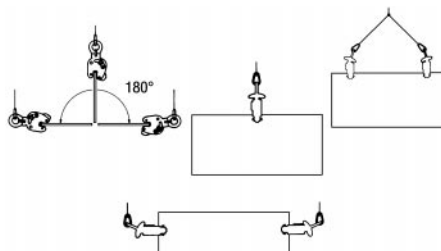
Rated Capacity (tons)	Plate Thickness <sup>①</sup>	Weight (lbs.)
1	0 – 3/4 3/4 – 1-1/4	17 19
2	0 – 1 3/4 – 1-1/2	23 27
4	1/4 – 1-1/2 1-1/4 – 2-1/2	45 48
8	1-1/2 – 3-1/4 1-3/4 – 3-1/2	193 195
12	2 – 4 3-3/4 – 5-1/2	200 220

<sup>①</sup> Available in other plate thicknesses for any of the above rated capacities.

**Table 8-12. Model SCP and SCPA – Locking, Screw – Specifications (Inches)**

Rated Capacity <sup>①</sup> (tons)	Plate Thickness <sup>①</sup>	Approximate Weight (lbs.)
1/2	0 – 3/4	8
1-1/2	0 – 1-1/4	14
3	0 – 2	19
6	0 – 2-1/2	44
10	0 – 3	93
15	0 – 4	210

<sup>①</sup> Capacities through 200 tons and various plate thicknesses available upon request.



**Table 8-13. Model M – Locking – Specifications (Inches)**

Rated Capacity (tons)	Jaw Opening ①	Weight (lbs.)
1/2	0 – 1 3/4 – 1-1/2	7 8
1	0 – 1 3/4 – 1-1/2	11 12
2	0 – 1-1/4 1 – 2	23 24
4	0 – 1-1/2 1-1/4 – 2-1/2	35 38
8	0 – 2 1-3/4 – 3-1/2	100 110

① Available with other jaw openings for any of the above rated capacities.

**Table 8-14. Model WHSR – Horizontal Lifting, Non-Locking – Specifications (Inches)**

Rated Capacity (tons)	Jaw Opening ①	Weight (lbs.)
1/2	0 – 6 0 – 12	23 30
1-1/2	0 – 6 0 – 12	32 45
3	0 – 6 0 – 12	35 46
6	0 – 6 0 – 12	62 64
8	0 – 6 0 – 12	83 98

① Available with other jaw openings for any of the above rated capacities.

**Table 8-15. Model SEA – Locking – Specifications (Inches)**

Rated Capacity (tons)	Jaw Opening	Weight (lbs.)
1	0 – 3/4	22
2	0 – 1	54
4	0 – 1 3/4 – 1-3/4	116 120
8	0 – 1-1/2 1 – 2-1/2	200 204
15	3/4 – 2 -1/4 2 – 3-1/2	343 350



**Model M**



**Model WHSR**



**Model SEA**

# PLATE LIFTING CLAMPS

Amick Associates, Inc.

## RENFROE® Plate Lifting Clamp Products

version #2-04

Made in the U.S.A. 

### "Little Brute" Model LBS

J.C. Renfroe does it again with the introduction of its small-but-mighty Model LBS, designed specifically for those times when you need a smaller, light-weight clamp to handle a big load. With a capacity rating of a 1/2 ton, the "Little Brute" is a vertical lifting clamp incorporating a 'Lock Open,' 'Lock Closed' feature making it easier to attach and remove the clamp from the plate.

J.C. Renfroe & Sons, Inc. of Jacksonville, Florida, has been an international leader in the manufacture and marketing of Lifting Clamps for over 60 years. Our superior quality and range of products are the reasons why.

**Table 8-16. "Little Brute" Model LBS – Specifications (Inches)**

Rated Capacity (tons)	Plate Thickness									Weight (lbs.)
	A	B	C	D	E	F	G	H	J	
1/2	0 – 5/8	2	5-1/16	8	1-1/8	4-1/4	2-1/8	1-1/4	3/8	4

**Note:** Specifications are subject to change without notice.

### Exclusion of Warranty

There exist no warranties, neither expressed nor implied, which extend beyond the descriptions or statements contained in the face or any part hereof.

### General Information

**Important:** Information contained in this catalog is for the presentation of pertinent illustrative and specification data for use in the selection of suitable RENFROE products consistent with the use intended by RENFROE. Refer to Operator's Manual for information on application, operation and maintenance of each particular model or product.

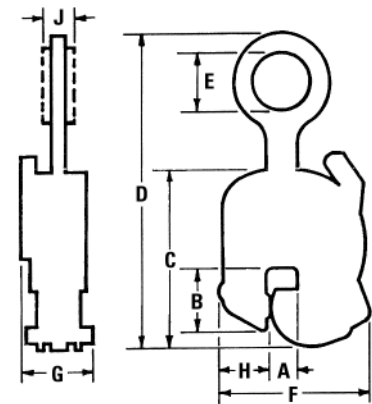
**Operator's Manual:** Prior to purchase and/or use of any RENFROE product, each purchaser and operator should read and understand fully all of the pertinent instructions and recommendations contained in the Operator's Manual for the particular product involved. The Operator's Manual contains recommended application, operation and maintenance instructions for all RENFROE products.

**Delays:** J.C. RENFROE & SONS, INC. is not liable for any delays in manufacturing or shipping caused by fire, strikes, lockouts, war, insurrections, inability to secure materials, government interference or regulations, delays in transportation, or other circumstances beyond reasonable control.

**Return of Goods:** No goods either standard or special may be returned for credit without written consent.

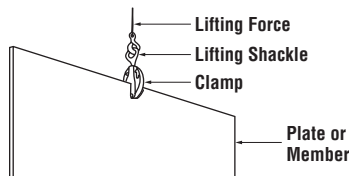


"Little Brute" Model LBS



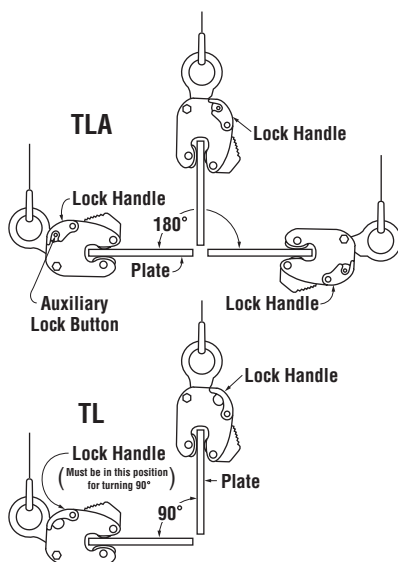
## Definitions

**Vertical Lift:** The lifting of a single plate or member in which the lifting force exerted by the rigging is directly above and in line with the lifting shackle as shown in the illustration below.



**Vertical Turn/Lift:** A vertical turn/lift clamp is a vertical lifting clamp specifically intended to turn a single plate or member through a 90° arc and back to vertical through the same 90° arc or from horizontal to vertical to horizontal through a 180° arc. Refer to Application Section of specific Turn/Lift clamps for further detail.

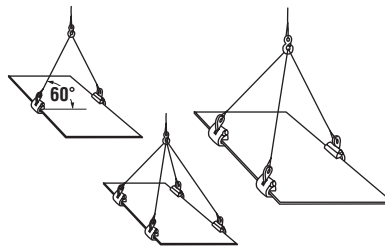
During the turning operation, the edge of the plate opposite the edge to which the clamp is attached should always be in contact with a supporting surface such as a factory floor, and the load on the clamp not exceed one half rated capacity of the clamp — Refer to illustrations shown below.



**Horizontal Lift:** Clamps (used in pairs or multiples) are attached to the side edges of a plate or bundle of plates positioned horizontally to the floor level. The rigging attached to the clamps is generally multi-legged slings with the connecting point of the slings being approximately centered between the distance separating the clamps. Refer to the illustrations below.

**WARNING: The capacity of all horizontal clamps is based on a sling angle of 60°. See illustration below. Sling angles less than 60° increase the load exerted on the clamps.**

**WARNING: The majority of horizontal clamps are rated in pairs — one half of the rated capacity is the maximum allowable load on one clamp.**



**Steel Plates:** Unless otherwise specified, lifting clamps are manufactured to handle hot-rolled steel plates whose Brinell Hardness does not exceed 300.

**WARNING: Do not lift plates with coatings or mill scale that prevent the gripping surfaces of the clamp from making positive contact with the base metal.**

For applications not covered by the above information, secure written recommendations from RENFROE.

**Finished and Polished Plates:** Steel plates in this category having other than hot-rolled surfaces such as stainless steel, etc., are generally handled using non-marring clamps incorporating smooth gripping surfaces.

**WARNING: For applications using clamps with serrated gripping surfaces on finished or polished plates, secure written recommendations from RENFROE.**

**Structural Members — Fabricated Sections:** Unless otherwise specified, clamps described as capable of handling structural members and fabricated sections are limited to hot-rolled steel whose Brinell Hardness does not exceed 300.

**WARNING: For applications not covered by the above information, secure written recommendations from RENFROE.**

**Rated Capacity:** The rated capacity of a RENFROE product is based on the product being in "new or as new" condition and represents the maximum load the product is to be subjected to when utilized in the manner described in this manual. Wear, misuse, abuse and other factors relating to usage may reduce the rated capacity. Shock loading and the factors listed must be taken into consideration when selecting a RENFROE product for a given application.

**Plate Thickness:** The minimum and maximum plate thickness a clamp specified for handling plates is capable of lifting.

**WARNING: Never use a clamp for lifting a plate where the plate thickness is less than or greater than the minimum and maximum stenciled on the clamp.**

**Jaw Opening:** The minimum and maximum thickness of a member a clamp specified as having a JAW OPENING is capable of handling.

**WARNING: Never use a clamp on a member whose thickness is less than or greater than the range of jaw opening stenciled on the clamp.**

**Operating Temperatures:** Unless specified under the Applications Section of the individual model, the approved operating temperature of RENFROE clamps is from 0°F (-18°C) to a maximum of 200°F (+93°C). The minimum and maximum temperatures apply to both ambient and the material being handled by the clamp.

**WARNING: Secure written authorization from RENFROE before using clamps in temperatures other than shown.**

**"Hot Lifts":** The Model R and S clamps are available in modifications that are capable of making lifts where the temperatures of the member being lifted exceeds 200°F (-93°C). Depending on conditions a lift may exceed 1000°F (538°C). The exact application and temperatures of the plates to be handled are critical in selecting the proper model.

**WARNING: Secure written instructions from RENFROE for all hot lift applications.**

# PLATE LIFTING CLAMPS

Amick Associates, Inc.

version #2-04

## Definitions

Made in the U.S.A. 

**Locking Clamps:** Locking clamps are divided into the categories listed below. With the exception of the "Locking Wedge" and "Locking Screw" type, the purpose of the locks are to facilitate the attaching and removing of the clamp from the member being handled.

**"Lock Closed":** An overcenter spring loaded mechanism in which the spring exerts a force on the gripping cam when the lock handle is moved to the "Lock Closed" position. When the handle is moved to unlocked position, the force exerted by the spring is relaxed and the gripping cam may be retracted by pushing the lifting shackle into body of the clamp. Refer to the Operation Section of specific models of "Lock Closed" clamps for additional details. Typical "Lock Closed" clamps are Models DG, FR and M.

**"Lock Open Only":** Normally used on "Hot Lift" clamps and consists of a manually operated "Lock Stop Pin" that is inserted when gripping cam of clamp is retracted and removed when clamp is positioned on the plate. Tag line may be used to permit operator to remove pin from a greater distance from clamp. Refer to the Operation Section of specific model of "Lock Open Only" clamps for additional details. Typical "Lock Open Only" clamp is the Model RO.

**"Lock Open-Lock Closed":** An overcenter spring loaded mechanism in which the spring exerts a force on the gripping cam when the lock handle is moved to the "Lock Closed" position. When the handle is moved to the "Lock Open", the gripping cam is maintained in the retracted position for ease in installing the clamp on a plate or member. The Model FRD contains individual "Lock Open" and "Lock Closed" mechanisms that must be operated separately. Refer to the Operation Section of specific models of the "Lock Open-Lock Closed" clamps for additional details. Typical "Lock Open-Lock Closed" clamps are Models FRD, R, S, SD, SEA, SX, TL and TLA.

**"Locking Wedge":** Is a fluted steel wedge that is driven in place with a hammer. The body of the wedge is positioned in a slot in the clamp body with the fluted edges contacting the member to which the clamp is being attached. Refer to Operation Section of specific models of the "Locking Wedge" clamps for additional details. Typical "Locking Wedge" clamps are Models A1, B1, B2 and PB.

**"Locking Screw":** "Lock Screw" clamps depend on manually adjusting a screw to hold the gripping surface in place for lifting and removing the clamp from member being lifted. Refer to Operation Section of a specific model of "Locking Screw" clamps for additional details. Typical "Locking Screw" clamps are Models NM, SCP and SCPA.

**Non-Locking:** "Non-Locking" clamps have no mechanisms to aid in attaching or removing clamp from member being lifted. It is necessary to have position of clamp maintained on the member being lifted until a properly applied force is exerted to the lifting shackle. Refer to Operation Section of specific models of the "Non-Locking" clamps for additional details. Typical "Non-Locking" clamps are Models AST, ASTL, BD, H, HD and WHS.

**WARNING:** A pointing out and notice of danger. The purpose of a "WARNING" is to apprise the operator and all other affected persons of the existence of danger of which he/she should be but may not be aware; and to enable the operator to protect himself and others, where applicable, against such danger. An attempt is made herein to warn against reasonable and reasonably foreseeable danger in the proper use and possible reasonable misuse of REN-FROE products described in this manual.

# HOISTS

---

## **Manual Hoists**

- CM Puller
- CM Cyclone Hand Chain Hoist
- CM Series 653 — Lever Operated Hoist
- CM Hurricane

## **Electric Chain Hoists**

- CM Lodestar Electric Chain Hoist
- CM Lodestar XL Electric Chain Hoist
- CM Shopstar Electric Chain Hoist
- CM Powerstar Electric Chain Hoist
- CM Airstar Air Hoist

## **Trolleys**

- CM Series 80 Trolleys for Hook Mounted Hoists (Push Type)
- CM Series 80 Trolleys for Hook Mounted Hoists (Hand Geared)
- CM Series 633 Wide Range Trolley
- Harrington Standard Headroom Trolley Hoists
- Harrington Single Speed Hook Suspension

## **Hoist Warnings**

## **Load Measurement**

- Dynafor®

## **Hoist Inspection and Repair**

---



# HOISTS

Amick Associates, Inc.

## Manual Hoists

version #2-04

Made in the U.S.A. 

### Manual Hoists

#### CM Puller

The CM Puller is designed for heavy-duty construction and industrial applications. Used to pull, lift, drag or stretch, it features:

- Tough aluminum alloy construction and powder coat finish.
- Weatherproof for outdoor service.
- Simple construction with fewer parts for ease of maintenance and lower inventories.
- Hoist alloy hardened steel link type load chain for strength, long wear life and flexibility.
- Weatherized Weston-type automatic braking system for positive load control.
- Easy, one-hand operation and control — only 58 pounds of pull required for 3/4 ton model capacity.
- Forged upper and lower hooks with latches standard.
- Free wheeling for fast and easy attachment to load.
- Upper and lower Latchlok hooks available for all capacities.
- Optional Load Limiter protection device stops transmission of lever forces protecting against dangerous overload.
- Optional anchor sling simplifies attachment to allow anchor hook to swivel in tight space applications (3/4 & 1-1/2 ton units only).
- Optional Load Sentry warns of overload condition.
- Optional shorter lever for 3/4 and 1-1/2 ton units available.
- Optional zinc-plated chain available.
- Unlimited lift.
- Lifetime warranty.
- Metric rated.
- Made in U.S.A.



3/4 Ton



1-1/2 Ton



3 Ton



6 Ton



Optional Shorter Lever



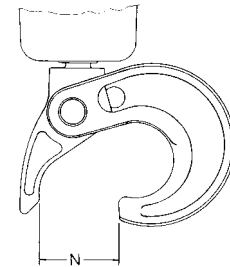
Optional Load Limiter



Optional Load Sentry



Optional Anchor Sling (3/4 and 1-1/2 ton)



Latchlok Type Hook

#### \*Warning – To avoid injury:

- Do not exceed working load limit, load rating, or capacity.
- Do not use to lift people or loads over people.
- Use only alloy chain for overhead lifting.
- Read and follow all instructions.

#### \*WARNING

Overloading and improper use can result in injury. See above.

### Cyclone Hand Chain Hoist

One of the most popular and reliable hoists ever designed, the Cyclone combines superior engineering, efficiency and durability. Available in a variety of capacities from 1/4 ton to 10 tons, Cyclone features:

- Most interchangeability of parts in the industry.
- Standard Load Limiter for simple, automatic overload protection.
- Enclosed contoured Weston-type automatic brake for positive load control.
- High-efficiency spur gearing for greater lift with minimum effort.
- Rugged Hoistaloy chain for added strength and durability.
- Fully machined, forged liftwheel pockets for easier lifting and smooth free chaining.
- High-strength aluminum alloy castings in frame and covers.
- Inspected over 75 times to meet or exceed HMI and ASME/ANSI performance and safety standards.
- Standard hand chain drop is 2 feet less than lift (example: 8 foot lift hoist has 6 foot hand chain drop).
- Chain containers, zinc-plated load and hand chain, aluminum unwelded hand chain, Latchlok hooks, bronze hooks, eye-type suspension, bullard hooks and units without Load Limiter optional, depending on capacity.
- Lifetime warranty.
- Metric rated.
- Made in U.S.A.



1/4 to 2 Ton Capacity



3 and 4 Ton Capacity



5 and 6 Ton Capacity



8 Ton Capacity



10 Ton Capacity

**Table 9-1. Specifications — Cyclone Hand Chain Hoist**

Rated Capacity (tons)	Product Code	Standard Lift <sup>①</sup> (ft.)	Reeving	Minimum Distance Between Hooks (in.)	Chain Overhauled to Lift Load One Foot (ft.)	Chain Pull to Lift Full Load (lbs.)	Shipping Weight (lbs.)
1/4	4621	8	1	12-7/8	22-1/2	23	37
1/2	4622	8	1	12-7/8	22-1/2	46	37
1	4624	8	1	14	30	69	40
1-1/2	4625	8	1	17-5/16	40-1/2	80	65
2	4626	8	1	17-5/16	52	83	64
3	4627	8	2	21-1/2	81	85	96
4	4628	8	2	21-1/2	104	88	96
5	4629	8	3	24-1/4	156	75	128
6	4630	8	3	25-1/4	156	90	132
8	4631	8	4	34-1/2	208	89	235
10	4632	8	5	35-1/2	260	95	249

<sup>①</sup> Can be supplied with longer lifts.

**\*Warning – To avoid injury:**

- Do not exceed working load limit, load rating, or capacity.
- Do not use to lift people or loads over people.
- Use only alloy chain for overhead lifting.
- Read and follow all instructions.

**\*WARNING** Overloading and improper use can result in injury. See above.

## Series 653 — Lever Operated Hoist

### Ideal for construction and industrial applications

The series 653 lever operated hoist is a high quality, rugged, steel tool for close quarter pulling, stretching, and hoisting applications. Its characteristic short handle, along with minimal lever pull effort, make this tool ideal for a broad range of applications.

- Impact resistant, stamped steel frame, gear case and cover for durability and light weight.
- Powder coated finish for added corrosion protection.
- Hardened steel load sharing gears.
- Double pawl arrangement for assured load control.
- Two chain guide rollers for positive chain engagement.
- Weston type braking system for positive load control and positioning.

- Simple one-handed, free chaining for fast load attachment.
- Hardened steel chain for strength and long wear life.
- Forged upper and lower hooks with heavy cast steel latches.
- Rubber handle grip for added operator comfort.
- Minimal maintenance with no special tools required.
- 5-year warranty against defects in materials and workmanship.
- Metric rated.
- Meets ASME B30.21 — Manually Lever Operated Hoist Standard and European CE Standard.
- Also available with Shipyard Hooks.
- Designed and manufactured by Columbus McKinnon Corporation.



Series 653 — Lever Operated Hoist

Table 9-2. Specifications — Series 653 — Lever Operated Hoist

Product Code	Rated Capacity		Standard Lift <sup>①</sup>		Reeving	Pull to Lift Full Load		Effective Lever Length <sup>②</sup>		Hook Throat Opening		Minimum Distance Between Hooks		Approximate Shipping Weight	
	(tons)	(kg)	(ft.)	(m)		(lbs.)	(kg)	(in.)	(mm)	(in.)	(mm)	(in.)	(mm)	(lbs.)	(kg)
5310	3/4	750	5	1.5	1	33	15	11	279	1-1/8	28.5	12-5/8	321	19	8.6
5311	3/4	750	10	3.0	1	33	15	11	279	1-1/8	28.5	12-5/8	321	21	9.5
5312	3/4	750	15	4.6	1	33	15	11	279	1-1/8	28.5	12-5/8	321	26	11.8
5313	3/4	750	5	1.5	1	33	15	11	279	1-1/8	28.5	12-5/8	321	28	12.7
5315	1-1/2	1500	10	3.0	1	51	23	16-1/4	413	1-1/4	31.8	14-13/16	376	31	14.1
5316	1-1/2	1500	15	4.6	1	51	23	16-1/4	413	1-1/4	31.8	14-13/16	376	36	16.3
5317	1-1/2	1500	15	4.6	1	51	23	16-1/4	413	1-1/4	31.8	14-13/16	376	41	18.6
5318	1-1/2	1500	20	6.0	1	51	23	16-1/4	413	1-1/4	31.8	14-13/16	376	45	20.4
5320	3	3000	5	1.5	1	77	35	16-1/4	413	1-9/16	39.7	18-11/16	475	51	23.1
5321	3	3000	10	3.0	1	77	35	16-1/4	413	1-9/16	39.7	18-11/16	475	59	26.8

<sup>①</sup> Can be supplied with lifts longer than 20 ft. (6 m).

<sup>②</sup> Measured from centerline of free chaining knob to end of lever.

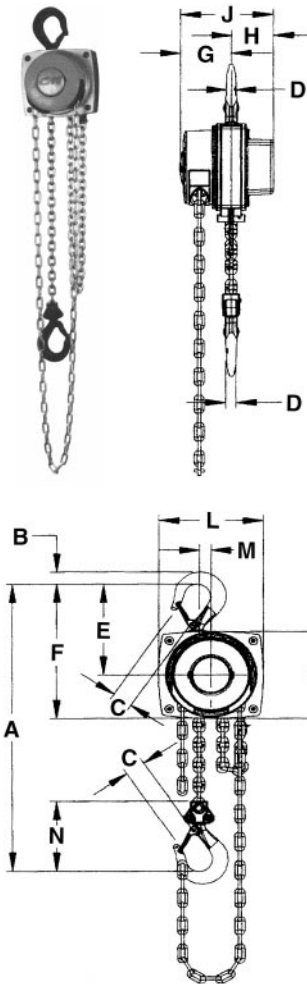
### \*Warning – To avoid injury:

- Do not exceed working load limit, load rating, or capacity.
- Do not use to lift people or loads over people.
- Use only CM alloy chain for overhead lifting.
- Read and follow all instructions.

### CM Hurricane

The **CM Hurricane hand chain hoist** is an economical, high-quality, rugged unit with features unique to a hoist of this class. Designed with fewer parts to assure long life and minimal maintenance, this hoist can be used to lift loads in numerous industrial, construction and commercial applications.

- **Unique Brake Design** — Single disc brake does not incorporate a ratchet pawl or pawl springs as on other hand chain hoists. Fewer parts mean less wear and low maintenance.
- **Unique Handwheel Cover** — Handwheel cover rotates 360° for hoist operation in any direction. Ideal for special rigging applications.
- **Steel Construction** — Frame and housings are made from impact resistant, stamped steel for long life.
- **Powder Coated Finish** — For corrosion protection.
- **Heat Treated Steel Gearing** — All internal gears and pinions are heat treated steel for high strength and long life.
- **Bearings** — High quality bushings and sealed ball bearings used throughout.
- **Chain Guide and Stripper** — Assures load chain alignment.
- **Precision 4-Pocket Liftwheel** — Fully machined for better chain fit and reduced wear.
- **Hardened Steel Chain** — Assures high strength and long wear life.
- **High Strength Hooks and Latches** — Forged upper and lower hooks with heavy duty cast steel latches.
- **Minimal Maintenance** — Easily disassembled, requiring no special tools.
- **Meets ASME B30.16** — Overhead Hoist Standard and European CE Standard.
- **5-Year Warranty** — Against defects in materials and workmanship.
- **Metric Rated.**
- **Designed and Manufactured by Columbus McKinnon Corporation.**



CM Hurricane Hand Chain Hoist

Table 9-3. Specifications — CM Hurricane

Product Code	Rated Capacity		Standard Lift ①		Hand Chain Pull to Lift Rated Load		Hand Chain Overhaul to Lift Load 1 ft. (.3 m)		Approximate Shipping Weight	
	(tons)	(kg)	(ft.)	(m)	(lbs.)	(kg)	(ft.)	(m)	(lbs.)	(kg)
5600	1/2	500	8	2.4	47	21	30	9.0	20	9.1
5602	1/2	500	12	3.6	47	21	30	9.0	24	10.9
5603	1/2	500	20	6.0	47	21	30	9.0	32	14.5
5604	1	1000	8	2.4	66	30	42	12.8	32	14.5
5605	1	1000	12	3.6	66	30	42	12.8	34	15.4
5606	1	1000	20	6.0	66	30	42	12.8	41	18.6
5607	2	2000	8	2.4	71	32	71	21.6	44	20.0
5608	2	2000	12	3.6	71	32	71	21.6	50	22.7
5609	2	2000	20	6.0	71	32	71	21.6	63	28.6

① Can be supplied with lifts other than those listed.

Table 9-4. Clearance Dimensions — CM Hurricane

Capacity (tons and kg)	Headroom													
	A	B	C	D	E	F	G	H	J	K	L	M	N	
<b>Dimensions in Inches (in.)</b>														
1/2 ton	11-13/16	11/16	15/16	7/16	5-1/2	8-1/8	3-1/16	2-7/16	5-7/16	5-1/4	5-7/8	15/16	4-3/8	
1 ton	13-1/8	7/8	1-1/8	13/16	6-1/2	9-9/16	3-7/16	2-3/4	6-3/16	6-1/4	6-7/8	15/16	4-15/16	
2 tons	15-9/16	1-1/8	1-3/8	15/16	7-9/16	11-1/8	3-15/16	3-1/4	7-3/16	7-3/16	8	1-1/4	6-1/8	
<b>Dimensions in Millimeters (mm)</b>														
500 kg	300.0	17.5	23.8	11.1	139.7	206.4	77.8	61.9	138.1	133.4	149.2	23.8	111.1	
1000 kg	333.4	22.2	28.6	20.6	165.1	242.9	87.3	69.9	157.2	158.8	174.6	23.8	125.4	
2000 kg	141.3	28.6	34.9	23.8	192.1	282.6	100.0	82.6	182.6	182.6	203.2	31.8	155.6	

**\*Warning – To avoid injury:**

- Do not exceed working load limit, load rating, or capacity.
- Do not use to lift people or loads over people.
- Use only CM alloy chain for overhead lifting.
- Read and follow all instructions.



Overloading and improper use can result in injury. See above.

## Electric Chain Hoist

### Lodestar Electric Chain Hoist

The balanced, integrated, proven design of the Lodestar has made it the most popular electric chain hoist in the industry. Lodestar gives you more value for your money including:

- Up to 3 ton capacities for heavy-duty industrial applications.
- Gear train lifetime lubricated with non-oxidizing grease.
- Precision machined and hardened liftwheel with hardened chain guides for precise chain liftwheel fit.
- Gearing designed for exceptionally long life and quiet operation.
- H4 duty standard.
- Rugged control station (NEMA 4)
- Hoist duty motor, standard Protector overload device and screw type limit switches.
- Hardened, forged steel, latch type hooks and Hoistaloy load chain for long, dependable service.
- Easy to install and maintain.
- No special tools required to disassemble.
- High reliability and long life.
- Designed for greater productivity, efficiency and economy.
- Lifetime warranty.
- Each hoist thoroughly inspected and tested to over 125% of rated load prior to shipment.
- Meets ASME B30.16.
- Metric rated.
- Made in U.S.A.

### Special Applications

- Harsh environment hoists available for severe duty of plating, galvanizing and washdown applications.
- Hoists with climbing capability available for temporary rigging or lifting applications — must be used in inverted position only.
- Hoists with creep control allow precise positioning through field adjustment within the time delay range of .05 sec. to 3 sec.
- Articulating suspension 3 ton only.



Single Reeved



Double Reeved



Triple Reeved

**Table 9-5. Specifications (Two Speed) — Lodestar Electric Chain Hoist**

Rated Capacity (tons)	Standard Lift (ft.)	Lift Speed (F.P.M.)	Motor hp	Model	Reeving	Product Code Less Suspension ①		Approximate Shipping Weight (lbs.)
						230-3-60	460-3-60	
1/8	10	10/32 20/60	1/4 1/2	A2 AA2	1 1	2707	2708	70
						2717	2718	74
1/4	10	5/16 10/32	1/4 1/2	B2 C2	1 1	2727	2728	70
						2737	2738	74
1/2	10	2.5/8 5/16 10/32 21/64	1/4 1/2 1 2	E2 F2 J2 JJ2	2 1 1 1	2747	2748	79
						2757	2758	74
						3502	3503	116
						3549	3550	130
1	10	2.5/8 5/16 10/32	1/2 1 2	H2 L2 LL2	2 1 1	2767	2768	83
						3504	3505	116
						3553	3554	130
2	10	2.5/8 5/16	1 2	R2 RR2	2 2	3506	3507	136
						3561	3562	150
3	10	1.75/5.5 3.5/11	1 2	RT2 RRT2	3 3	9511	9513	161
						9512	9514	175

① Specify voltage 230 or 460.

### \*Warning – To avoid injury:

- Do not exceed working load limit, load rating, or capacity.
- Do not use to lift people or loads over people.
- Use only alloy chain for overhead lifting.
- Read and follow all instructions.

### Lodestar XL Electric Chain Hoist

The Lodestar XL has been designed to meet severe to extreme conditions. Features include a forged 10-pocket oblique lay liftwheel and 7/16" diameter case hardened load chain which significantly increases chain life; also an overload protector, and case hardened gears that operate in an oil bath. Hoist meets H-4 duty requirements, and has a thermally protected hoist motor, heavy duty hoist brake and regenerative braking. Meets or exceeds ANSI B30.16 requirements. All the above contribute to an extremely rugged, durable, dependable hoist which has become synonymous with the name "CM Lodestar."

The Lodestar XL is available in 3-phase, dual voltage, single speed; and 3-phase, single voltage, two speed. Hoists are sold with either upper hook, plain, geared or motor driven trolley.

The Lodestar XL electric chain hoist features:

- Two to 6 ton capacities for heavy-duty industrial applications.
- Forged 10 pocket oblique lay liftwheel for smooth chain operation, constant chain speed and reduced chain wear.
- Gearing operates in oil bath. Designed for exceptionally long life and quiet operation.
- Heavy-duty multiple disc braking system.
- Hardened forged steel latch type hooks.
- Hoist alloy load chain for long, dependable service.
- Thermally protected hoist duty motor.
- Standard Protector overload device.
- Standard screw type limit switches.
- Easy installation and maintenance.
- Provides high reliability and long life.
- Rated H-4, heavy duty.
- Factory tested at 125% of rated capacity prior to shipment.
- Meets ASME B30.16.
- Lifetime warranty.
- Metric rated.
- Made in U.S.A.



2 Ton Single Reeved at 18 or 24 F.P.M.



3 and 4 Ton Double Reeved at 9 or 12 F.P.M.



5 and 6 Ton Triple Reeved at 6 or 8 F.P.M.

**Table 9-6. Specifications — Lodestar XL Electric Chain Hoist**

Rated Capacity* (tons)	Single Speed ① (F.P.M.)	Voltage Single Speed Hoist	Two Speed ① (F.P.M.)	Voltage Two Speed Hoist	Reeving	Standard Lift (ft.)	Maximum Lift (ft.)	Motor hp	Approximate Shipping Weight Single Speed With Hook Suspension
2	18	230/460	6/18	230 or 460	1	10	127	3.5	368
	24	230/460	8/24	230 or 460	1	10	139	3.5	368
3	9	230/460	3/9	230 or 460	2	10	63	3.5	442
	12	230/460	4/12	230 or 460	2	10	69	3.5	442
4	9	230/460	3/9	230 or 460	2	10	63	3.5	442
	12	230/460	4/12	230 or 460	2	10	69	3.5	442
5	6	230/460	2/6	230 or 460	3	10	42	3.5	474
	8	230/460	2.7/8	230 or 460	3	10	46	3.5	474
6	6	230/460	2/6	230 or 460	3	10	42	3.5	474
	8	230/460	2.7/8	230 or 460	3	10	46	3.5	474

① All lifting speeds are based on 60 hertz power supply. When operating on 50 hertz, the speeds are 5/6 of those listed.

**Note:** 1 speed hoist is convertible dual voltage.

**Note:** 2 speed hoist is single voltage and not convertible.

**Note:** Control station meets NEMA 4 requirements.

**Note:** Hoist head meets NEMA 1.

**Note:** Standard power cord is 2.5 ft. long.

**Note:** Optional weatherproofing (NEMA 3R).

**Note:** Lodestar XL is not available for operation on single-phase power systems.

**\*Warning – To avoid injury:**

- Do not exceed working load limit, load rating, or capacity.
- Do not use to lift people or loads over people.
- Use only alloy chain for overhead lifting.
- Read and follow all instructions.



**\*WARNING** Overloading and improper use can result in injury. See above.

# HOISTS

Amick Associates, Inc.

## Electric Chain Hoist

version #2-04

Made in the U.S.A. 

### Shopstar Electric Chain Hoist

The Shopstar electric chain hoist features rugged construction and high H4 duty cycle. It keeps lifting and lifting, up to 600 pounds and 300 motor starts per hour. Additional features and benefits include:

- H4 duty cycle (300 motor starts/hour).
- Easy installation and maintenance.
- Standard protector overload device.
- 10 pocket oblique lay liftwheel provides longer chain wear.
- Epoxy powder coat finish.
- 6-1/2 ft. power cord with molded 3 prong plug.
- NEMA 12 industrial rated control station.
- Optional impact-resistant chain container available.
- Gear train lifetime lubricated with non-oxidizing grease.
- CM Hoist Alloy Load Chain (zinc plated optional).
- Thermally protected hoist duty motor.
- Dual braking system — D.C. plus regenerative.
- Rugged cast aluminum alloy hoist frame.
- 5:1 design factor.
- Small, compact design for commercial & industrial applications.
- Rigid hook suspension prevents tangling of power cord.
- Hardened forged steel latch style lower hook rotates 360°.
- Totally enclosed non-ventilated hoist frame protects motor from environmental contamination.
- True vertical lift.
- Precision bearings used throughout hoist.
- Lifetime warranty.
- Metric rated.
- Made in U.S.A.

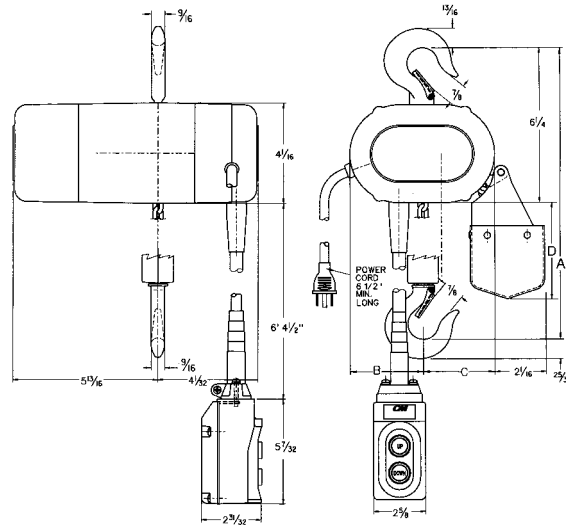


Table 9-7. Clearance Dimensions (in.)

Rated Capacity (lbs.)	A	B	C	D
300	10-7/8	3	2-15/16	3-7/8
600	11-15/16	3-9/16	2-3/8	5-3/4

Table 9-8. Shopstar Chain Container

Product Code	Maximum Length of Lift (ft.)	
	300#	600#
2010	10	5
2011	20	10
2013	30	15
2014	70	35

Table 9-9. Specifications — Shopstar Electric Chain Hoist

Product Code				Maximum Capacity (lbs.)	Lifting Speed F.P.M.	Lift (ft.)	Approximate Shipping Weight (lbs.)	Motor hp
115-1-60	230-1-60	230-3-60	460-3-60					
2000	—	—	—	300	16	10	26	1/6
—	2023	2026	2029	300	16	10	28	1/6
2002	—	—	—	300	16	15	27	1/6
—	2024	2027	2030	300	16	15	29	1/6
2004	—	—	—	300	16	20	28	1/6
—	2025	2028	2031	300	16	20	30	1/6
2001	—	—	—	600	8	10	32	1/6
—	2032	2035	2038	600	8	10	34	1/6
2003	—	—	—	600	8	15	35	1/6
—	2033	2036	2039	600	8	15	37	1/6
2005	—	—	—	600	8	20	37	1/6
—	2034	2037	2040	600	8	20	39	1/6

**\*Warning – To avoid injury:**

- Do not exceed working load limit, load rating, or capacity.
- Do not use to lift people or loads over people.
- Use only alloy chain for overhead lifting.
- Read and follow all instructions.

**\*WARNING**

Overloading and improper use can result in injury. See above.

**Powerstar Electric Chain Hoist**

Designed specifically as an alternative to wire rope hoists for high speed lifting of loads from 2 to 20 tons in a space-saving chain hoist. Features:

- H-4 or better rated duty cycle.
  - Designed for heavy-duty industrial applications from 2 to 20 ton capacities.
  - Liftwheel has machined chain pockets and is heat treated alloy steel for maximum strength and wear resistance.
  - Efficient regenerative braking system avoids heat generation in power train.
  - Heavy-duty multiple disc D.C. brake (dual braking system).
  - Motors up to 7-1/2 hp provide a wide range of lifting speeds.
  - Single or two speed controls. Two speed models operate on 3:1 speed ratio.
  - Standard adjustable upper and lower screw limit switches.
  - Standard adjustable upper and lower screw limit switches.
  - Standard overload Protector device.
  - Hardened forged steel latch type hooks.
  - Fits most crane packages.
  - Hoist alloy load chain can be easily inspected for wear and abuse.
  - Flexible chain container is standard on all units up to a 20 ft. lift.
  - True vertical lift.
  - Factory tested to 125% of rated capacity prior to shipment.
  - Close end approach.
  - Lifetime warranty.
  - Metric rated except for 10 and 20 ton capacities.
  - Made in U.S.A.
  - Two through 20 ton capacities available.
  - Lug (2 through 6 ton capacities only) and trolley (plain, geared and motorized) suspensions available.
  - Rugged aluminum alloy hoist frame.
  - Chain guide surrounds liftwheel.
  - Machined and hardened steel Helical gears used throughout hoist for optimum performance and mechanical efficiency.
  - Fully enclosed hook block with forged steel conventional latch type hook is standard on 2 through 20 ton units. Latchlok hooks available on 2 through 6 ton units.
  - Extensive use of life-lubricated bearings plus sealed oil bath power train reservoir for minimum maintenance.
  - CM's hardened alloy steel, flexible Hoist alloy load chain provides high strength and long service life.
  - Dual braking system.
  - Heavy duty, industrial single speed controls include magnetic reversing contactor which operates on 115 volts provided by a control transformer.
  - Totally enclosed, ball bearing, 30 minute rated, thermally protected, hoist duty motor is standard.
  - Pushbutton control is weatherproof (NEMA 4 rated).
  - Drop of pushbutton control is 4 ft. above hook at lowest position, unless otherwise specified.
  - External pushbutton chain strain relief is standard.
  - Power cord length is 2-1/2 ft. unless otherwise specified.
  - Trolley design permits easy adjustment for installation on a broad range of beam flange widths.
  - Rugged welded steel trolley frame with bumper/rail guards projecting inward over flange to provide added protection.
  - Trolley wheels have double row, tapered roller bearings plus machined and hardened universal treads to permit operation on American Standard or flat flanged sections interchangeably.
  - Spur gearing used in all motorized trolleys for improved efficiency and durability.
  - Drop of hand chain on geared trolleys is 2 ft. above hook at lowest position, unless otherwise specified.
  - Designed to be maintained "on the beam."
  - Up to 600 lineal feet of chain.
  - Weatherproof (NEMA 3R).
- \*Warning – To avoid injury:**
- Do not exceed working load limit, load rating, or capacity.
  - Do not use to lift people or loads over people.
  - Use only alloy chain for overhead lifting.
  - Read and follow all instructions.

**Single Reeved****Double Reeved****Triple Reeved**

# HOISTS

Amick Associates, Inc.

## Electric Chain Hoist

version #2-04

Made in the U.S.A. 

### Airstar Air Hoist

Designed for general commercial applications where variable speed pneumatic power is preferable. Rated for 1/4, 1/2 and 1 ton capacities, this compact, lightweight hoist features:

- Hoist alloy load chain for heavy duty or stainless steel chain for spark resistant, medium duty loads.
- Positive action, heavy-duty shoe type brake that holds the load.
- Multi-vane rotary air motor for high torque, smooth operation.
- Accurately machined heat treated alloy steel spur gears.
- Spark resistant models available for hazardous environments.
- Pull cord or pendant throttle control available.
- Pull cord control hoists provide a lightweight, economical hoist for accurate control of loads.
- Optional pendant throttle control hoists offer ergonomic, one-hand control for ease of operation.
- Hook or lug suspension available.
- Inlet air swivel with built-in strainer provides free hoist movement.
- Aluminum frame and end cover contributes to the lightweight, easily portable, and rugged design.
- External brake adjustment.
- Limit stops prevent over-travel in upper and lowering directions.
- Equa-torque gearing of alloy steel, heat treated spur gears are accurately machined to provide a close meshed, compact gear reduction.
- Tapped exhaust port 1/2 NPTF...for CLEAN applications or to add a supplemental muffler in addition to the built-in muffler for even quieter operation.
- Lifetime warranty.
- Metric rated.
- Made in U.S.A.

### Basic Hoist Data

**Rated Loads:** 1/4, 1/2 and 1 Ton (Spark resistant models are rated at 3/8 and 3/4 ton).

**Lift:** 10 foot lifts are standard. Longer lifts are an optional extra.

**Pendant Control:** 6 foot length is standard. Longer lengths are an optional extra.

**Optional:** For greater corrosion resistance, a plated load chain is offered as an optional extra.

### Air Pressure

**Recommended:** 90 PSI

**Air Consumption:** 48 SCFM at 90 PSI

**Net Wt. (Basic Hoist):** 36 lbs.

**Suspension:** Hook or lug

**Control:** Pull Cord or Pendant Throttle

**Air Inlet:** 3/8 NPTF

**Air Supply Hose:** 1/2 I.D. min.

**Air Exhaust:** 1/2 NPTF

### \*Warning – To avoid injury:

- Do not exceed working load limit, load rating, or capacity.
- Do not use to lift people or loads over people.
- Use only alloy chain for overhead lifting.
- Read and follow all instructions.



### \* WARNING

Overloading and improper use can result in injury. See above.

## Trolleys

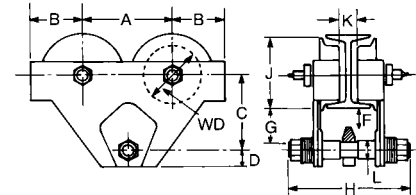
### Series 80 Trolleys for Hook Mounted Hoists Push Type

#### Hook Suspension

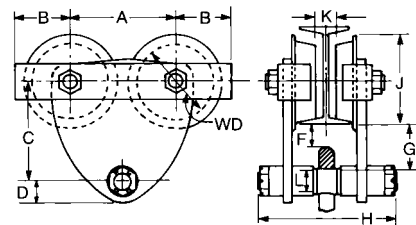
- Available in 1/4 ton to 3 ton capacities.
- Can be used with any hook suspended hoist.
- Runs on either American Standard or wide flange shapes.
- Trolley side frames feature all steel construction for strength and durability.
- Steel wheels with hardened treads and ball bearings provide easy and long life.
- Hand-gearred trolleys are ideal for accurate positioning and long lifts.

#### Rigid Mount

- For use with lug suspended hoists such as the CM Airstar or Airstar 6.
- Available in 1/2 to 3 ton capacities.
- Trolleys attach directly to the lug brackets on the hoist.
- Offers minimum headroom.
- Push, hand-gearred, or motorized models available.
- On hand-gearred models, anti-tilt rollers eliminate the tilting of the trolley when operating with a light load.
- Features a lifetime warranty and are made in U.S.A.



1/4, 1/2, 1 and 2 Ton



3 Ton Only

Table 9-10. Clearance Dimensions (Inches) — Series 80 Trolleys for Hook Mounted Hoists Push Type

Rated Capacity (tons)	Product Code	A	B	C	D	WD	Minimum F <sup>①</sup>	G	H	J	Minimum K <sup>②</sup>	L
1/4	80	4-3/8	2-13/16	4-1/8	1	3-1/8	3/4	1-13/16	7-9/16	3-15/16	11/16	7/8
	80SR	4-3/8	2-13/16	4-1/8	1	3-1/8	3/4	1-13/16	7-9/16	3-15/16	11/16	7/8
	80WFA	4-3/8	2-13/16	4-1/8	1	3-1/8	3/4	1-13/16	9-7/8	3-15/16	3-1/6	7/8
1/2	81	4-3/8	2-13/16	4-1/8	1	3-1/8	3/4	1-13/16	7-9/16	3-15/16	11/16	7/8
	81SR	4-3/8	2-13/16	4-1/8	1	3-1/8	3/4	1-13/16	7-9/16	3-15/16	11/16	7/8
	81WFA	4-3/8	2-13/16	4-1/8	1	3-1/8	3/4	1-13/16	9-7/8	3-15/16	3-1/6	7/8
1	82	6-1/8	3-9/16	5-1/8	1-1/8	4	1-1/16	2-1/4	8-1/4	4-7/8	13/16	1
	82SR	6-1/8	3-9/16	5-1/8	1-1/8	4	1-1/16	2-1/4	8-1/4	4-7/8	13/16	1
	82WFA	6-1/8	3-9/16	5-1/8	1-1/8	4	1	2-3/16	10-3/8	4-7/8	2-13/16	1
	82WFB	6-1/8	3-9/16	5-1/8	1-1/8	4	1	2-3/16	12-3/8	4-7/8	4-13/16	1
2	83	6-7/8	3-13/16	5-3/4	1-5/16	4-15/16	13/16	2-1/4	8-3/4	—	3/4	1-1/8
	83SR	6-7/8	3-13/16	5-3/4	1-5/16	4-15/16	13/16	2-1/4	8-3/4	—	3/4	1-1/8
	83WFA	6-7/8	3-13/16	5-3/4	1-5/16	4-15/16	3/4	2-3/16	10-3/4	—	3-3/8	1-1/4
	83WFB	6-7/8	3-13/16	5-3/4	1-5/16	4-15/16	3/4	2-3/16	12-3/4	—	5-3/8	1-1/4
3	905480	6-7/8	4-3/8	1-5/8	4-15/16	4-15/16	9/16	2-3/8	12	6	1-1/4	1-13/32
	905481	6-7/8	4-3/8	1-5/8	4-15/16	4-15/16	9/16	2-3/8	14-3/4	6	4-1/4	1-13/32
	905482	6-7/8	4-3/8	1-5/8	4-15/16	4-15/16	9/16	2-3/8	17-5/8	6	7	1-13/32

① Clearance dimensions "F" and "G" are based on the largest beam on which trolley will operate. Dimension increases slightly for each smaller beam size.

② Dimension "K" occurs on smallest beam size only. On larger beams it is increased by the difference in flange width.

#### \*Warning – To avoid injury:

- Do not exceed working load limit, load rating, or capacity.
- Do not use to lift people or loads over people.
- Use only alloy chain for overhead lifting.
- Read and follow all instructions.



**WARNING**

Overloading and improper use can result in injury. See above.

## Series 80 Trolleys for Hook Mounted Hoists Push Type (Continued)

**Table 9-11. Specifications — Series 80 Trolleys for Hook Mounted Hoists Push Type**

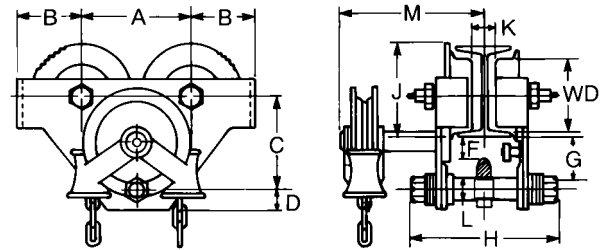
Rated Capacity (tons)	Product Code	Minimum Beam Depth (in.)	Minimum Radius Curve	Adjustable Flange Width (in.)	Approximate Net Weight (lbs.)
1/4	80	4	2'6"	2-5/8 – 4-5/8	13
	80SR	4	2'6"	2-5/8 – 4-5/8	13
	80WFA	4	2'6"	5 – 7	14
1/2	81	4	2'6"	2-5/8 – 4-5/8	13
	81SR	4	2'6"	2-5/8 – 4-5/8	13
	81WFA	4	2'6"	5 – 7	14
1	82	5	3'0"	3 – 5	25
	82SR	5	3'0"	3 – 5	25
	82WFA	5	3'0"	5 – 7	26
	82WFB	5	3'0"	7 – 9	27
2	83	6	4'0"	3-3/8 – 6	35
	83SR	6	4'0"	3-5/8 – 6	35
	83WFA	6	4'0"	6 – 8	36
	83WFB	6	4'0"	8 – 10	37
3	905480	6	4'0"	3-3/8 – 6	41
	905481	6	4'0"	6-1/8 – 8-7/8	43
	905482	6	4'0"	9 – 11	44

**\*Warning – To avoid injury:**

- Do not exceed working load limit, load rating, or capacity.
- Do not use to lift people or loads over people.
- Use only alloy chain for overhead lifting.
- Read and follow all instructions.

## Series 80 Trolleys for Hook Mounted Hoists Hand Geared

■ Made in U.S.A.



1, 2 and 3 Ton

**Table 9-12. Clearance Dimensions (Inches) — Series 80 Trolleys for Hook Mounted Hoists Hand Geared**

Rated Capacity (tons)	Product Code	A	B	C	D	WD	Minimum F <sup>①</sup>	G	H	J	Minimum K <sup>②</sup>	L	M
1	82G	6-1/8	3-9/16	5-1/8	1-1/8	4	1-1/16	2-1/4	8-1/4	4-7/8	13/16	1	—
	82GSR	6-1/8	3-9/16	5-1/8	1-1/8	4	1-1/16	2-1/4	8-1/4	5-1/2	13/16	1	10-3/16
	82GWFA	6-1/8	3-9/16	5-1/8	1-1/8	4	1	2-13/16	10-3/8	5-1/2	2-13/16	1	11-15/16
	82GWFB	6-1/8	3-9/16	5-1/8	1-1/8	4	1	2-13/16	12-3/8	5-1/2	4-13/16	1	11-15/16
2	83G	6-7/8	3-13/16	5-3/4	1-5/16	4-15/16	13/16	2-1/4	8-3/4	6-5/16	3/4	1-1/8	10-9/16
	83GSR	6-7/8	3-13/16	5-3/4	1-5/16	4-15/16	13/16	2-1/4	8-3/4	6-5/16	3/4	1-1/8	10-9/16
	83GWFA	6-7/8	3-13/16	5-3/4	1-5/16	4-15/16	3/4	2-3/16	10-3/4	6-5/16	3-3/8	1-1/4	11-7/8
	83GWFB	6-7/8	3-13/16	5-3/4	1-5/16	4-15/16	3/4	2-3/16	12-3/4	6-5/16	5-3/8	1-1/4	12-7/16
3	905490	6-7/8	4-3/16	6	1-5/8	4-15/16	9/16	2-3/8	12	6-5/16	1-1/4	1-13/32	8-5/16
	905491	6-7/8	4-3/16	6	1-5/8	4-15/16	9/16	2-3/8	14-3/4	6-5/16	4-1/4	1-13/32	19-13/16
	905492	6-7/8	4-3/16	6	1-5/8	4-15/16	9/16	2-3/8	17-5/8	6-5/16	7	1-13/32	21-3/16

① Clearance dimensions "F" and "G" are based on the largest beam on which trolley will operate. Dimension increases slightly for each smaller beam size.

② Dimension "K" occurs on smallest beam size only. On larger beams it is increased by the difference in flange width.

**Table 9-13. Specifications — Series 80 Trolleys for Hook Mounted Hoists Hand Geared**

Rated Capacity (tons)	Product Code	Minimum Beam Depth (in.)	Minimum Radius Curve (ft.)	Adjustable Flange Width (in.)	Approximate Net Weight (lbs.)
1	82G	5	3	3 – 5	25
	82GSR	5	3	3 – 5	25
	82GWFA	5	3	5 – 7	26
	82GWFB	5	3	7 – 9	27
2	83G	6	4	3-3/8 – 6	35
	83GSR	6	4	3-3/8 – 6	35
	83GWFA	6	4	6 – 8	36
	83GWFB	6	4	8 – 10	37
3	905490	6	4	3-3/8 – 6	41
	905491	6	4	6-1/8 – 8-7/8	43
	905492	6	4	9 – 11	44

**\*Warning – To avoid injury:**

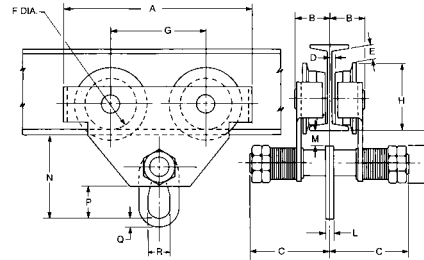
- Do not exceed working load limit, load rating, or capacity.
- Do not use to lift people or loads over people.
- Use only alloy chain for overhead lifting.
- Read and follow all instructions.



**WARNING**

Overloading and improper use can result in injury. See above.

## CM Series 633 Wide Range Trolley



Simple, rugged, built for trouble-free service and ease of operation across a wide range of beam applications. Series 633 features:

- Rugged steel side plates formed to include bumpers and trolley guards.
- Frames connected by steel equalizer pin, secured by two nuts on each side.
- Universal tread flanged trackwheels equipped with shielded ball bearings.
- Easy rolling on American standard shapes, wide flange shapes or patented rail.
- Hardened wheels and axles for added strength and durability.
- Spacer washers can be shifted inside or outside for easy adjustment to wide range of beams.
- To be used with hook suspended hoist.
- Suspension plate for easy attachment is standard.
- Bearings prepacked with lifetime lubricant.
- One-year warranty.
- Imported.

**Table 9-14. Clearance Dimensions (Inches) — CM Series 633 Wide Range Trolley**

Dimension	Rated Capacity (tons)				
	1/2	1	2	3	5
Min. radius curve (in.)	35	35	59	71	94
A	8-1/2	10-13/16	12-7/32	14-13/16	18-1/8
B ①	2-5/32	2-13/32	2-11/16	3-1/16	3-21/32
C	5-1/16	6-9/16	6-25/32	7-13/32	8
D ①	1/16	7/16	13/32	1/2	9/16
E ①	-1/4	11/32	25/32	1-7/16	2-3/16
F	2-9/32	3-15/32	3-15/16	5-1/8	6-1/8
G	4	4-7/8	5-1/2	6-9/16	7-7/8
H ①	3	4-11/32	4-29/32	6-1/8	7-9/32
J ①	1-1/32	1-1/32	25/32	1-3/16	2-1/8
K	1-3/4	2-3/32	2-1/2	3-13/32	3-13/32
L	1/2	1/2	5/8	5/8	13/16
M ①	15/16	31/32	5/16	15/16	1-7/16
N ①	4-3/32	5-1/16	5-13/16	7-7/16	9-15/16
P	1-7/32	1-3/4	2-5/32	2-9/16	3-23/32
Q	1-9/32	19/32	13/16	1-3/8	1-25/32
R	31/32	1-5/32	1-5/8	1-31/32	2-9/16

① Dimensions given are for minimum S-beam and will vary with larger beams.

**Table 9-15. Specifications — CM Series 633 Wide Range Trolley**

Rated Capacity (tons)	Product Code	Adjustable for Standard S-Beams		Tread Diameter (in.)	Net Weight (lbs.)	Shipping Weight (lbs.)
		Depth of Beam (in.)	Flange Width (in.)			
1/2	3302	3 – 15	2-1/2 – 5-5/8	2-9/32	15	17
1	3304	5 – 24	3 – 8	3-15/32	34	36
	3306	6 – 24	3-5/8 – 8	3-15/16	50	53
3	3307	8 – 24	4 – 8	5-1/8	95	100
5	3309	10 – 24	4-5/8 – 8	6-1/8	172	175

**Note:** All capacities can be supplied for S-beams larger than listed and also for wide flange beams, rails or tracks with approximately equivalent flange widths.

**\*Warning – To avoid injury:**

- Do not exceed working load limit, load rating, or capacity.
- Do not use to lift people or loads over people.
- Use only alloy chain for overhead lifting.
- Read and follow all instructions.



**WARNING**

Overloading and improper use can result in injury. See above.



## Standard Headroom Trolley Hoists



Standard Headroom Trolley Hoist

For general use on bridge, gantry or jib cranes, as well as monorails, this standard Harrington monorail style trolley hoist combines versatility and performance.

- Available in any combination of single or dual speed models in a variety of speed combinations.
- Hoist oriented parallel to beam.
- For features and standard specifications, refer to **Tables 9-16** and **9-17**.
- For detailed specifications and dimensions, refer to Harrington's separate publication entitled "Electric Wire Rope Hoists Technical Manual."

### Options

- Pendant.
- Pendant cord.
- Power supply cord.
- Trolley travel limit switch.

**Table 9-16. Hoist Specifications — Standard Headroom Trolley Hoists**

Capacity (tons)	Product Code	Lift (ft.)	Lifting Speed (ft./min.)		Reeving (Parts/Reeving)	Rope <sup>①</sup> (mm-Spec.)	Single Speed Lifting Motor 3 Phase 60 Hz			Dual Speed Lifting Motor 3 Phase 60 Hz			Net Weight (lbs.)
			Single Speed	Dual Speed			Output (hp)	Rated Current (Amps)		Output (hp)	Rated Current (Amps)		
								@460V	@230V		@460V	@230V	
2	RH02S-20 <sup>②</sup> 4C- <sup>③-④</sup>	20	16	16/5	4/1	7-B	4.8	7.7	15.4	4.8/1.6	7.7/6.3	15.4/12.5	529
	RH02S-29 <sup>②</sup> 4C- <sup>③-④</sup>	29	16	16/5	4/1	7-B	4.8	7.7	15.4	4.8/1.6	7.7/6.3	15.4/12.5	573
	RH02S-20 <sup>②</sup> 4D- <sup>③-④</sup>	20	24	24/8	4/1	7-B	4.8	7.7	15.4	4.8/1.6	7.7/6.3	15.4/12.5	529
2	RH02S-29 <sup>②</sup> 4D- <sup>③-④</sup>	29	24	24/8	4/1	7-B	4.8	7.7	15.4	4.8/1.6	7.7/6.3	15.4/12.5	573
	RH02S-39 <sup>②</sup> 3A- <sup>③-④</sup>	39	32	32/10	2/1	7-A	4.8	7.7	15.4	4.8/1.6	7.7/6.3	15.4/12.5	509
	RH02S-79 <sup>②</sup> 3A- <sup>③-④</sup>	79	32	32/10	2/1	7-A <sup>⑤</sup>	4.8	7.7	15.4	4.8/1.6	7.7/6.3	15.4/12.5	551
3	RH03S-20 <sup>②</sup> 4C- <sup>③-④</sup>	20	16	16/5	4/1	7-A	4.8	7.7	15.4	4.8/1.6	7.7/6.3	15.4/12.5	529
	RH03S-29 <sup>②</sup> 4C- <sup>③-④</sup>	29	16	16/5	4/1	7-A	4.8	7.7	15.4	4.8/1.6	7.7/6.3	15.4/12.5	573
	RH03S-23 <sup>②</sup> 4H- <sup>③-④</sup>	23	24	24/8	4/1	9-B	8.0	11.5	23.0	8.0/2.7	11.5/9.6	23.0/19.0	728
3	RH03S-33 <sup>②</sup> 4H- <sup>③-④</sup>	33	24	24/8	4/1	9-B	8.0	11.5	23.0	8.0/2.7	11.5/9.6	23.0/19.0	794
	RH03S-46 <sup>②</sup> 3E- <sup>③-④</sup>	46	32	32/10	2/1	9-A	8.0	11.5	23.0	8.0/2.7	11.5/9.6	23.0/19.0	617
	RH03S-85 <sup>②</sup> 3E- <sup>③-④</sup>	85	32	32/10	2/1	9-A <sup>⑤</sup>	8.0	11.5	23.0	8.0/2.7	11.5/9.6	23.0/19.0	672
5	RH05S-23 <sup>②</sup> 4G- <sup>③-④</sup>	23	16	16/5	4/1	9-A	8.0	11.5	23.0	8.0/2.7	11.5/9.6	23.0/19.0	728
	RH05S-33 <sup>②</sup> 4G- <sup>③-④</sup>	33	16	16/5	4/1	9-A	8.0	11.5	23.0	8.0/2.7	11.5/9.6	23.0/19.0	794
	RH05S-23 <sup>②</sup> 4M- <sup>③-④</sup>	23	24	24/8	4/1	13-B	16.1	21.0	42.0	16.1/5.4	23.0/17.3	46.0/34.5	1918
	RH05S-33 <sup>②</sup> 4M- <sup>③-④</sup>	33	24	24/8	4/1	13-B	16.1	21.0	42.0	16.1/5.4	23.0/17.3	46.0/34.5	2083
5	RH05S-46 <sup>②</sup> 4J- <sup>③-④</sup>	46	32	32/10	2/1	13-A	16.1	21.0	42.0	16.1/5.4	23.0/17.3	46.0/34.5	1378
	RH05S-92 <sup>②</sup> 4J- <sup>③-④</sup>	92	32	32/10	2/1	13-A <sup>⑤</sup>	16.1	21.0	42.0	16.1/5.4	23.0/17.3	46.0/34.5	1543
	RH05S-52 <sup>②</sup> 4P- <sup>③-④</sup>	52	48	48/16	2/1	16-B	25.7	33.0	69.0	19.2/6.3	36.5/29.0	79.0/60.0	2690
	RH05S-X5 <sup>②</sup> 4P- <sup>③-④</sup>	105	48	48/16	2/1	16-B	25.7	33.0	69.0	19.2/6.3	36.5/29.0	79.0/60.0	2954
7-1/2	RH08S-23 <sup>②</sup> 4L- <sup>③-④</sup>	23	16	16/5	4/1	13-M	16.1	21.0	42.0	16.1/5.4	23.0/17.3	46.0/34.5	1918
	RH08S-33 <sup>②</sup> 4L- <sup>③-④</sup>	33	16	16/5	4/1	13-M	16.1	21.0	42.0	16.1/5.4	23.0/17.3	46.0/34.5	2083
	RH08S-23 <sup>②</sup> 3M- <sup>③-④</sup>	23	24	24/8	4/1	13-B	16.1	21.0	42.0	16.1/5.4	23.0/17.3	46.0/34.5	1918
7-1/2	RH08S-33 <sup>②</sup> 3M- <sup>③-④</sup>	33	24	24/8	4/1	13-B	16.1	21.0	42.0	16.1/5.4	23.0/17.3	46.0/34.5	2083
	RH08S-52 <sup>②</sup> 4N- <sup>③-④</sup>	52	32	32/10	2/1	16-A	25.7	33.0	69.0	19.2/6.3	36.5/29.0	79.0/60.0	2690
	RH08S-X5 <sup>②</sup> 4N- <sup>③-④</sup>	105	32	32/10	2/1	16-A <sup>⑤</sup>	25.7	33.0	69.0	19.2/6.3	36.5/29.0	79.0/60.0	2954
10	RH10S-23 <sup>②</sup> 4L- <sup>③-④</sup>	23	16	16/5	4/1	13-A	16.1	21.0	42.0	16.1/5.4	23.0/17.3	46.0/34.5	1918
	RH10S-33 <sup>②</sup> 4L- <sup>③-④</sup>	33	16	16/5	4/1	13-A	16.1	21.0	42.0	16.1/5.4	23.0/17.3	46.0/34.5	2083
	RH10S-26 <sup>②</sup> 4R- <sup>③-④</sup>	26	24	24/8	4/1	16-B	25.7	33.0	69.0	19.2/6.3	36.5/29.0	79.0/60.0	3351
10	RH10S-36 <sup>②</sup> 4R- <sup>③-④</sup>	36	24	24/8	4/1	16-B	25.7	33.0	69.0	19.2/6.3	36.5/29.0	79.0/60.0	3660
	RH10S-52 <sup>②</sup> 3N- <sup>③-④</sup>	52	32	32/10	2/1	16-A	25.7	33.0	69.0	19.2/6.3	36.5/29.0	79.0/60.0	2690
	RH10S-X5 <sup>②</sup> 3N- <sup>③-④</sup>	105	32	32/10	2/1	16-A <sup>⑤</sup>	25.7	33.0	69.0	19.2/6.3	36.5/29.0	79.0/60.0	2954
15	RH15S-26 <sup>②</sup> 4Q- <sup>③-④</sup>	26	16	16/5	4/1	16-A	25.7	33.0	69.0	19.2/6.3	36.5/29.0	79.0/60.0	3351
	RH15S-36 <sup>②</sup> 4Q- <sup>③-④</sup>	36	16	16/5	4/1	16-A	25.7	33.0	69.0	19.2/6.3	36.5/29.0	79.0/60.0	3660
20	RH20S-26 <sup>②</sup> 3Q- <sup>③-④</sup>	26	16	16/5	4/1	16-A	25.7	33.0	69.0	19.2/6.3	36.5/29.0	79.0/60.0	3351
	RH20S-36 <sup>②</sup> 3Q- <sup>③-④</sup>	36	16	16/5	4/1	16-A	25.7	33.0	69.0	19.2/6.3	36.5/29.0	79.0/60.0	3660

① Rope type identified as B, M or A. Specify type when ordering replacement rope.

② S = Single Speed Hoist, D = Dual Speed Hoist.

③ 2 = 230V – 3ph – 60 Hz, 4 = 460V – 3ph – 60 Hz.

④ Traversing Speed: F = 40 ft./min., G = 64 ft./min., H = 80 ft./min., V = 64/16 ft./min., W = 80/20 ft./min.

⑤ Optional wider flange ranges available. Wider flange range is the standard lower value to 15.75 inch. (Example: Wider flange range for 2 ton trolley hoists is 3.54 to 15.75 inches.)



Made in the U.S.A.

Table 9-17. Trolley Specifications — Standard Headroom Trolley Hoists

Capacity (tons)	Product Code	Standard Flange Range B <sup>①</sup> (in.)	Traversing Motors								
			Single Speed 40 ft./min.			Single Speed 64 and 80 ft./min.			Dual Speed 64/16 and 80/20 ft./min.		
			Output (hp)	Rated Current (Amps)		Output (hp)	Rated Current (Amps)		Output (hp)	Rated Current (Amps)	
				@460V	@230V		@460V	@230V		@460V	@230V
2	RH02S-20 <sup>②</sup> 4C- <sup>③</sup> - <sup>④</sup>	3.54 to 11.02	0.32	1.1	2.2	0.6	1.1	3.0	0.6/0.13	1.3/1.1	2.5/2.2
	RH02S-29 <sup>②</sup> 4C- <sup>③</sup> - <sup>④</sup>	3.54 to 11.02	0.32	1.1	2.2	0.6	1.1	3.0	0.6/0.13	1.3/1.1	2.5/2.2
	RH02S-20 <sup>②</sup> 4D- <sup>③</sup> - <sup>④</sup>	3.54 to 11.02	0.32	1.1	2.2	0.6	1.1	3.0	0.6/0.13	1.3/1.1	2.5/2.2
2	RH02S-29 <sup>②</sup> 4D- <sup>③</sup> - <sup>④</sup>	3.54 to 11.02	0.32	1.1	2.2	0.6	1.1	3.0	0.6/0.13	1.3/1.1	2.5/2.2
	RH02S-39 <sup>②</sup> 3A- <sup>③</sup> - <sup>④</sup>	3.54 to 11.02	0.32	1.1	2.2	0.6	1.1	3.0	0.6/0.13	1.3/1.1	2.5/2.2
	RH02S-79 <sup>②</sup> 3A- <sup>③</sup> - <sup>④</sup>	3.54 to 11.02	0.32	1.1	2.2	0.6	1.1	3.0	0.6/0.13	1.3/1.1	2.5/2.2
3	RH03S-20 <sup>②</sup> 4C- <sup>③</sup> - <sup>④</sup>	3.54 to 11.02	0.32	1.1	2.2	0.6	1.1	3.0	0.6/0.13	1.3/1.1	2.5/2.2
	RH03S-29 <sup>②</sup> 4C- <sup>③</sup> - <sup>④</sup>	3.54 to 11.02	0.32	1.1	2.2	0.6	1.1	3.0	0.6/0.13	1.3/1.1	2.5/2.2
	RH03S-23 <sup>②</sup> 4H- <sup>③</sup> - <sup>④</sup>	4.69 to 11.02	0.32	1.1	2.2	0.6	1.1	3.0	0.6/0.13	1.3/1.1	2.5/2.2
3	RH03S-33 <sup>②</sup> 4H- <sup>③</sup> - <sup>④</sup>	4.69 to 11.02	0.32	1.1	2.2	0.6	1.1	3.0	0.6/0.13	1.3/1.1	2.5/2.2
	RH03S-46 <sup>②</sup> 3E- <sup>③</sup> - <sup>④</sup>	3.54 to 11.02	0.32	1.1	2.2	0.6	1.1	3.0	0.6/0.13	1.3/1.1	2.5/2.2
	RH03S-85 <sup>②</sup> 3E- <sup>③</sup> - <sup>④</sup>	3.54 to 11.02	0.32	1.1	2.2	0.6	1.1	3.0	0.6/0.13	1.3/1.1	2.5/2.2
5	RH05S-23 <sup>②</sup> 4G- <sup>③</sup> - <sup>④</sup>	4.69 to 11.02	0.32	1.1	2.2	0.6	1.1	3.0	0.6/0.13	1.3/1.1	2.5/2.2
	RH05S-33 <sup>②</sup> 4G- <sup>③</sup> - <sup>④</sup>	4.69 to 11.02	0.32	1.1	2.2	0.6	1.1	3.0	0.6/0.13	1.3/1.1	2.5/2.2
	RH05S-23 <sup>②</sup> 4M- <sup>③</sup> - <sup>④</sup>	5.31 to 11.02	0.5	1.1	2.2	0.9	1.5	4.4	0.9/0.2	2.1/1.1	4.2/2.2
	RH05S-33 <sup>②</sup> 4M- <sup>③</sup> - <sup>④</sup>	5.31 to 11.02	0.5	1.1	2.2	0.9	1.5	4.4	0.9/0.2	2.1/1.1	4.2/2.2
5	RH05S-46 <sup>②</sup> 4J- <sup>③</sup> - <sup>④</sup>	4.69 to 11.02	0.32	1.1	2.2	0.6	1.1	3.0	0.6/0.13	1.3/1.1	2.5/2.2
	RH05S-92 <sup>②</sup> 4J- <sup>③</sup> - <sup>④</sup>	4.69 to 11.02	0.32	1.1	2.2	0.6	1.1	3.0	0.6/0.13	1.3/1.1	2.5/2.2
	RH05S-52 <sup>②</sup> 4P- <sup>③</sup> - <sup>④</sup>	5.31 to 11.02	0.5	1.1	2.2	0.9	1.5	4.4	0.9/0.2	2.1/1.1	4.2/2.2
	RH05S-X5 <sup>②</sup> 4P- <sup>③</sup> - <sup>④</sup>	5.31 to 11.02	0.5	1.1	2.2	0.9	1.5	4.4	0.9/0.2	2.1/1.1	4.2/2.2
7-1/2	RH08S-23 <sup>②</sup> 4L- <sup>③</sup> - <sup>④</sup>	5.31 to 11.02	0.5	1.1	2.2	0.9	1.5	4.4	0.9/0.2	2.1/1.1	4.2/2.2
	RH08S-33 <sup>②</sup> 4L- <sup>③</sup> - <sup>④</sup>	5.31 to 11.02	0.5	1.1	2.2	0.9	1.5	4.4	0.9/0.2	2.1/1.1	4.2/2.2
	RH08S-23 <sup>②</sup> 3M- <sup>③</sup> - <sup>④</sup>	5.31 to 11.02	0.5	1.1	2.2	0.9	1.5	4.4	0.9/0.2	2.1/1.1	4.2/2.2
7-1/2	RH08S-33 <sup>②</sup> 3M- <sup>③</sup> - <sup>④</sup>	5.31 to 11.02	0.5	1.1	2.2	0.9	1.5	4.4	0.9/0.2	2.1/1.1	4.2/2.2
	RH08S-52 <sup>②</sup> 4N- <sup>③</sup> - <sup>④</sup>	5.31 to 11.02	0.5	1.1	2.2	0.9	1.5	4.4	0.9/0.2	2.1/1.1	4.2/2.2
	RH08S-X5 <sup>②</sup> 4N- <sup>③</sup> - <sup>④</sup>	5.31 to 11.02	0.5	1.1	2.2	0.9	1.5	4.4	0.9/0.2	2.1/1.1	4.2/2.2
10	RH10S-23 <sup>②</sup> 4L- <sup>③</sup> - <sup>④</sup>	5.31 to 11.02	0.5	1.1	2.2	0.9	1.5	4.4	0.9/0.2	2.1/1.1	4.2/2.2
	RH10S-33 <sup>②</sup> 4L- <sup>③</sup> - <sup>④</sup>	5.31 to 11.02	0.5	1.1	2.2	0.9	1.5	4.4	0.9/0.2	2.1/1.1	4.2/2.2
	RH10S-26 <sup>②</sup> 4R- <sup>③</sup> - <sup>④</sup>	6.69 to 11.02	0.5	1.1	2.2	0.9	1.5	4.4	0.9/0.2	2.1/1.1	4.2/2.2
10	RH10S-36 <sup>②</sup> 4R- <sup>③</sup> - <sup>④</sup>	6.69 to 11.02	0.5	1.1	2.2	0.9	1.5	4.4	0.9/0.2	2.1/1.1	4.2/2.2
	RH10S-52 <sup>②</sup> 3N- <sup>③</sup> - <sup>④</sup>	5.31 to 11.02	0.5	1.1	2.2	0.9	1.5	4.4	0.9/0.2	2.1/1.1	4.2/2.2
	RH10S-X5 <sup>②</sup> 3N- <sup>③</sup> - <sup>④</sup>	5.31 to 11.02	0.5	1.1	2.2	0.9	1.5	4.4	0.9/0.2	2.1/1.1	4.2/2.2
15 <sup>⑤</sup>	RH15S-26 <sup>②</sup> 4Q- <sup>③</sup> - <sup>④</sup>	6.69 to 11.02	0.5 x 2	1.1 x 2	2.2 x 2	0.9 x 2	1.5 x 2	4.4 x 2	0.9/0.2 x 2	2.1/1.1 x 2	4.2/2.2 x 2
	RH15S-36 <sup>②</sup> 4Q- <sup>③</sup> - <sup>④</sup>	6.69 to 11.02	0.5 x 2	1.1 x 2	2.2 x 2	0.9 x 2	1.5 x 2	4.4 x 2	0.9/0.2 x 2	2.1/1.1 x 2	4.2/2.2 x 2
20 <sup>⑤</sup>	RH20S-26 <sup>②</sup> 3Q- <sup>③</sup> - <sup>④</sup>	6.69 to 11.02	0.5 x 2	1.1 x 2	2.2 x 2	0.9 x 2	1.5 x 2	4.4 x 2	0.9/0.2 x 2	2.1/1.1 x 2	4.2/2.2 x 2
	RH20S-36 <sup>②</sup> 3Q- <sup>③</sup> - <sup>④</sup>	6.69 to 11.02	0.5 x 2	1.1 x 2	2.2 x 2	0.9 x 2	1.5 x 2	4.4 x 2	0.9/0.2 x 2	2.1/1.1 x 2	4.2/2.2 x 2

- ① Optional wider flange ranges available. Wider flange range is the standard lower value to 15.75 inch. (Example: Wider flange range for 2 ton trolley hoists is 3.54 to 15.75 inches.)
- ② S = Single Speed Hoist, D = Dual Speed Hoist.
- ③ 2 = 230V – 3ph – 60 Hz, 4 = 460V – 3ph – 60 Hz.
- ④ Traversing speed: F = 40 ft./min., G = 64 ft./min., H = 80 ft./min., V = 64/16 ft./min., W = 80/20 ft./min.
- ⑤ 15 and 20 ton models are equipped with 2 trolley motors.



## Single Speed Hook Suspension

Manufactured to Meet the Demands of Real World Markets

- Standard length of power supply cable is 15'. For more information on power supply system, contact the Harrington distributor nearest you.
- Special lengths of load chain, push-button cord or power supply cables are available upon request.
- Harrington load chain is case-hardened Grade 80 chain.
- Optional canvas chain containers are available.
- Optional steel chain containers are available if lifting height exceeds limit of canvas container.



Harrington Single Speed Hook Suspension

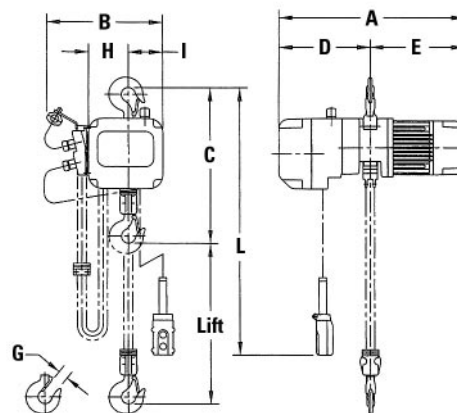
Table 9-18. Dimensions (Inches) — Harrington Single Speed Hook Suspension

Product	Minimum Headroom: C	A	B	D	E	G	H	I
ER001H	13.8	21.1	13.0	10.4	10.7	0.9	4.0	3.9
ER003S	13.8	21.1	13.0	10.4	10.7	0.9	4.0	3.9
ER003H	14.6	21.9	13.8	10.8	11.1	0.9	4.7	4.1
ER005L	14.0	21.1	13.0	10.4	10.7	0.9	4.0	3.9
ER005S	14.6	21.9	13.8	10.8	11.1	0.9	4.7	4.1
ER010L	16.3	21.9	13.8	10.8	11.1	1.2	4.7	4.1
ER010S	17.3	25.6	16.5	12.6	13.0	1.2	6.1	5.2
ER015S	20.5	25.6	16.5	12.6	13.0	1.3	6.1	5.2
ER020L	22.0	25.6	16.5	12.6	13.0	1.5	6.1	5.2
ER020S	24.0	30.9	18.9	15.5	15.5	1.5	7.2	6.5
ER025S	24.6	30.9	18.9	15.5	15.5	1.6	7.2	6.5
ER030L	26.0	30.9	18.9	15.5	15.5	1.7	7.2	6.5
ER030S	26.0	30.9	18.9	15.5	15.5	1.7	7.2	6.5
ER050L	32.9	30.9	18.9	15.5	15.5	1.8	9.6	4.0

Note: Lug mount available. Consult factory.

Table 9-19. Specifications — Harrington Single Speed Hook Suspension

Capacity (tons)	Product Code	Standard Lift	Push Button Cord: L (ft)	Lifting Speed (ft./min.)	Lifting Motor 3 Phase 60 Hz			Load Chain Diameter (mm) x Chain Fall Lines	Net Weight (lbs.)	Weight for Additional One Foot of Lift (lbs.)
					Output (hp)	Rated Current (amps)				
						@230V (208V)	@460V			
1/8	ER001H	10	7.2	57	0.75	4.2	2.1	5.0 x 1	68	0.37
1/4	ER003S	10	7.2	39	0.75	4.2	2.1	5.0 x 1	68	0.37
1/4	ER003H	10	7.2	60	1.2	5.7	2.9	6.3 x 1	86	0.57
1/2	ER005L	10	7.2	15	0.75	4.2	2.1	6.3 x 1	70	0.57
1/2	ER005S	10	7.2	30	1.2	5.7	2.9	6.3 x 1	86	0.57
1	ER010L	10	7.2	16	1.2	5.7	2.9	8.0 x 1	90	0.93
1	ER010S	10	7.2	29	2.4	10.5	5.3	8.0 x 1	134	0.93
1-1/2	ER015S	10	7.2	20	2.4	10.5	5.3	10.0 x 1	150	1.5
2	ER020L	10	7.2	14	2.4	10.5	5.3	10.0 x 1	150	1.5
2	ER020S	10	8.2	28	4.7	18.3	9.2	10.0 x 1	238	1.5
2-1/2	ER025S	10	8.2	23	4.7	18.3	9.2	11.2 x 1	249	1.9
3	ER030L	10	8.2	16	4.7	18.3	9.2	12.5 x 1	256	2.3
3	ER030S	10	8.2	22	6.2	25.1	12.6	12.5 x 1	269	2.3
5	ER050L	10	8.2	12	4.7	18.3	9.2	11.2 x 2	308	4.0



### Hoist Warnings

#### DO's and DO NOT's — Operating Chain Hoists

The following warnings and operating practices have been taken from American National (Safety) Standard ANSI B30.16 and are intended to avoid unsafe hoisting practices which might lead to personal injury or property damage.

These recommendations apply to all hand chain manually operated chain hoists for vertical lifting service involving material handling of freely suspended unguided loads.

#### Warning – To avoid injury:

- DO** read ANSI B30.16 Safety Standard for Overhead Hoists and the Hoist Manufacturer's Operating and Maintenance Instructions.
- DO** be familiar with hoist operating controls, procedures and warnings.
- DO** make sure the hoist suspension hook is securely attached to a suitable support.
- DO** maintain firm footing or be otherwise secured when operating hoist.
- DO** make sure that load slings or other approved single attachments are properly sized and seated in the hook saddle.
- DO** make sure the hook latch, if used, is closed and not supporting any part of the load.
- DO** make sure that load is free to move and will clear all obstructions.
- DO** take up slack carefully, check load balance, lift a few inches, and check load holding action before continuing.
- DO** make sure all persons stay clear of the suspended load.
- DO** avoid swinging of load or load hook.
- DO** protect load chain from weld spatter or other damaging contaminants.
- DO** promptly report any malfunction, unusual performance, or damage, of the hoist.
- DO** inspect hoist regularly, replace damaged or worn parts, and keep appropriate records of maintenance.
- DO** use the hoist manufacturer's recommended parts when repairing a hoist.
- DO** use hook latches wherever possible.
- DO** apply lubricant to load chain as recommended by the hoist manufacturer.
- DO NOT** lift more than rated load.
- DO NOT** use the hoist load limiting device to measure the load.
- DO NOT** use damaged hoist or hoist that is not working correctly.
- DO NOT** use hoist with twisted, kinked, damaged, or worn chain.
- DO NOT** lift a load unless chain is properly seated in chain wheel(s) or sprocket(s).
- DO NOT** use load chain as a sling or wrap load chain around the load.
- DO NOT** lift a load if any binding prevents equal loading on all supporting chains.
- DO NOT** apply the load to the tip of the hook.
- DO NOT** operate unless load is centered under hoist.
- DO NOT** operate hoist with other than manual power.
- DO NOT** permit more than one operator to pull on a single hand chain at one time.
- DO NOT** allow your attention to be diverted from operating the hoist.
- DO NOT** operate hoist beyond limits of load chain travel.
- DO NOT** use hoist to lift, support, or transport people.
- DO NOT** lift loads over people.
- DO NOT** leave a suspended load unattended unless specific precautions have been taken.
- DO NOT** allow sharp contact between two hoists or between hoist and obstructions.
- DO NOT** allow the chain or hook to be used as a ground for welding.
- DO NOT** allow the chain or hook to be touched by a live welding electrode.
- DO NOT** remove or obscure the warnings on the hoist.
- DO NOT** adjust or repair a hoist unless qualified to perform hoist maintenance.
- DO NOT** attempt to lengthen the load chain or repair damaged load chain.

**Note:** The equipment illustrated here is not designed or suitable as a power source for lifting or lowering persons. Exceeding rated capacity is dangerous and can result in injury to persons and property damage.

**Note:** Specifications and dimensions are subject to change without notice.

## Load Measurement

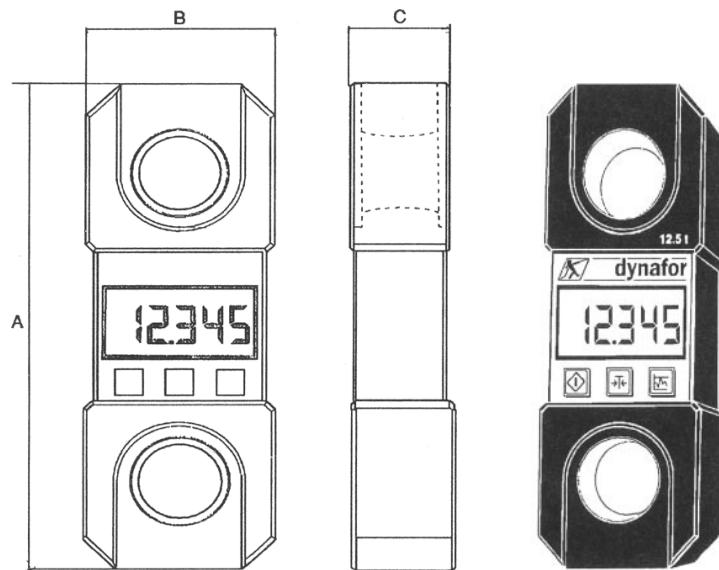
### Dynafor® — The new shape of load measurement today!

The new Dynafor® LLX range of load indicating devices are accurate compact instruments for measuring tensile forces and loads. Designed for use on tough jobsite conditions, the Dynafor LLX load indicators can be used for the following applications:

- Avoiding the overload of man-riding platforms.
- Under hook check weighing for mobile and overhead cranes.
- Testing of material handling equipment.
- On-hook weighing of goods during manufacturing.
- Check weighing in shipping and receiving operations.
- Weighting loads on multi-point lifts.

#### Technical Features

- Lightweight aluminum alloy construction.
- Microprocessor-based operations.
- Pushbutton operation and programming.
- Automatic zero when unit is turned on.
- Multiple units of measurement (display choices vary with models): Lbs., Tons, Metric Tonne, Kg, DaN, kN.
- Output for display for connection to a personal computer.
- Up to 7 Dynafor units may be connected to a personal computer at one time.
- Ambient temperature range: -15°F to 120°F (-10°C to +50°C).
- Accuracy: ±0.2% of capacity.
- Up to 250 hours of operation with 3 AA alkaline batteries.
- Auto shut-off for extended life.
- Weatherproof and dustproof: IP 65.



**Table 9-20. Specifications — Dynafor LLX**

Model	Capacity in lbs. (tons)	Accuracy in lbs. (tons)	Smallest Load in lbs. (tons)	Maximum Display	Dimension — A x B x C in inches (mm)	Height of Digits (in.)	Weight in lbs. (kg)
LLX-25	500	1	0.2	500	7.5 x 3.2 x 2.2 (190 x 83 x 56)	3/4	2.5 (1.1)
LLX-50	1,000	2	0.5	1,000	7.5 x 3.2 x 2.2 (190 x 83 x 56)	3/4	2.5 (1.1)
LLX-1.50	2,500	5	1	2,500	7.5 x 3.2 x 2.2 (190 x 83 x 56)	3/4	2.5 (1.1)
LLX-2.5	5,000	10	2	5,000	8.4 x 3.2 x 2.2 (214 x 83 x 56)	3/4	3 (1.9)
LLX-5	10,000	20	5	10,000	9.2 x 3.5 x 2.2 (234 x 90 x 56)	3/4	4 (1.8)
LLX-12.5	25,000	50	10	25,000	12.2 x 4.3 x 2.3 (310 x 110 x 58)	1	8.4 (3.8)
LLX-25	50,000	100	20	50,000	14.1 x 5.3 x 2.7 (360 x 134 x 68)	1	14.5 (6.6)
LLX-50	100,000	200	10	10,000	17.3 x 6.5 x 3.9 (440 x 164 x 98)	1	33 (15.1)
LLX-100	(100T)	(0.2T)	(0.05T)	100	26.0 x 10.2 x 4.7 (660 x 260 x 18)	1	101 (46)
LLX-250	(250T)	(0.5T)	(0.1T)	250	35.6 x 16.7 x 9.8 (905 x 424 x 248)	1-3/4	474 (215)

**Note:** All conversions from metric are approximate.

# HOISTS

*Amick Associates, Inc.*

## Hoist Inspection and Repair

version #2-04

### Hoist Inspection and Repair

Amick Associates is able to inspect and repair all brands of hoists and pullers in house. Amick Associates also offers onsite inspection and repairs on all brands of hoist.

# LODERAIL

---

## **Overhead Rail — Steel**

Specifications

General Description

Photo Description

## **Overhead Rail — Extruded Aluminum**

General Description



## Overhead Rail – Steel

### Specifications

- Capacity: up to 4,000 lbs.
- Width: to 34 feet.
- Length: as required.
- Height: to 17 feet.

### General Description

#### It's Revolutionary

- Pre-engineered yet versatile.
- Self-supporting yet rigid.
- Seismic designed.
- Ergonomic benefits.
- High productivity.
- Modular.
- Relocatable.
- High resale value.

#### It's LodeRail

A manually operated floor-supported work area crane available with manual, electric, or air powered hoisting unit configured for your work area.

#### ■ Earthquake Resistant

LodeRail meets all the stringent requirements of the Uniform Building Code, Seismic Zone 4 which covers the most severe earthquake prone areas in the United States. Your LodeRail is designed to take whatever your application requires or nature imposes.

#### ■ Entirely Self-Supporting

While others provide similar products, the LodeRail is the only true self-supporting crane system of its kind in the market today. You don't need any X-bracing, building tie backs or kickers for any configuration.

#### ■ Ergonomically Justified

OSHA will soon introduce a new set of National Ergonomic Standards. Reduce injuries while increasing productivity with less effort. You can manually move your load on LodeRail with a 100:1 productivity ratio, e.g., an operator can start a 500 pound load moving with 5 pounds of force. Over 100 billion dollars is paid annually by USA employers in direct and indirect workers' compensation claims.

Lower costs for workers' compensation and higher productivity translates into increased profits.

### LodeRail: Economical, Efficient

#### ■ Increased Floor Space

Complete hook coverage under the crane reduces the need for vehicle traffic, increasing valuable floor space for production.

#### ■ Lower Labor Costs

One person with a crane can precisely position and assemble parts more efficiently and safely than three men using a forklift.

### LodeRail: A Simple Solution

#### ■ Easy to Install

Installation can usually be done with your own crew. Frames bolt directly to most floors.

#### ■ Easy to Order

Our pre-engineered standard components make ordering easy and deliveries fast.

#### ■ Easy to Extend or Relocate

Unique all bolted construction and modular design makes it easy to add sections or to disassemble and relocate.

### A Complete System

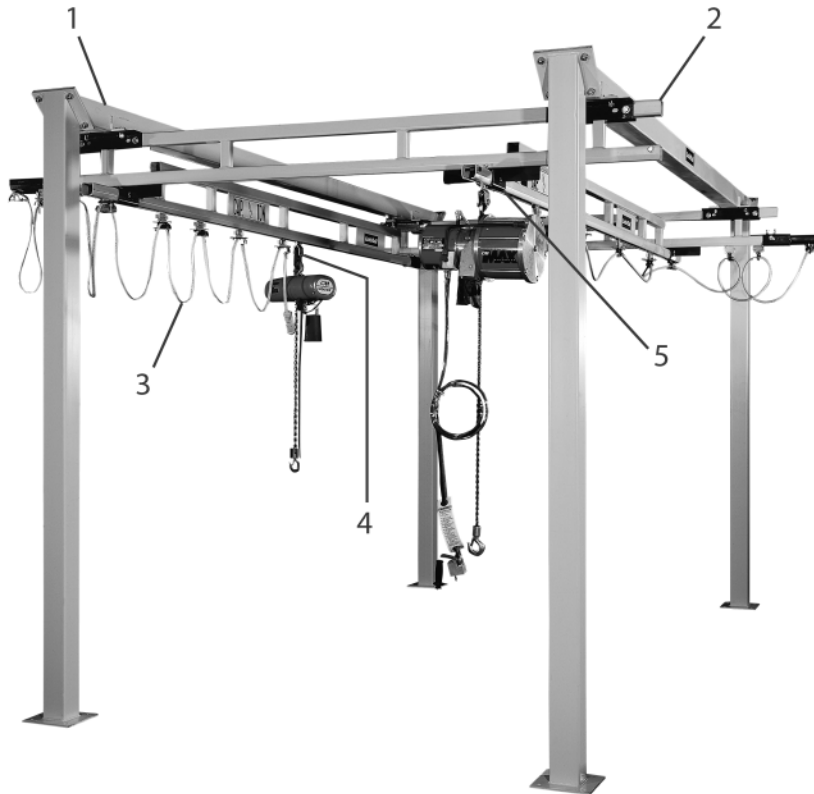
Your LodeRail crane is a complete system. You get the runway structure, runway rails, festoon electrification for the bridge and runway, the bridge, trolleys and even the bolts for the floor. Color is yellow for the bridges, runways and frames. Custom colors are available on special order.

#### Also Available

Ceiling mounted systems and powered cranes for special applications.



### Photo Description



#### 3. Festoon Electrification

Festoon 4-wheel trolleys are standard for supporting flat cable or air hose along the length of runway and bridge. Air hose trolleys have swivel type support saddles.



#### 4. Smooth Rolling Trolleys

The hoist trolleys, with load bar, provide the means for suspending the hoist. Wheels are tapered to match the taper of the track, reducing rolling resistance. Wheel bearings are sealed and lubricated for life. Trolleys are designed to operate in temperatures from +5°F to 200°F.



#### 5. Free Moving End Trucks

Our bridge girder floats free in one end truck and the other is firmly clamped, allowing for any slight misalignment of the runway tracks. The trucks also have two horizontal wheels that center the truck within the track to prevent binding of the bridge. Wheels are tapered to match the taper of the track which reduces rolling resistance. Wheel bearings are sealed and lubricated for life.

#### \*Warning – To avoid injury:

- Do not exceed working load limit, load rating, or capacity.
- Do not use to lift people or loads over people.
- Read and follow all instructions.

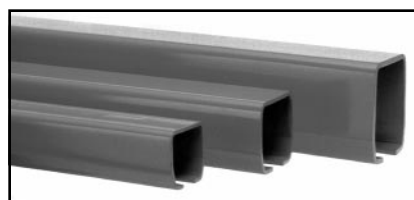
### A.N.S.I. Compliance

LodeRail complies with the American National Standard ASME B30.11 titled Safety Standard for Monorails and Underhung Cranes.



#### 1. Rigid Runways

Unique rigid seismic designed runway connection provides a far superior track suspension system than a flexible type suspension, for accurately moving and positioning loads.



#### 2. Enclosed Steel Track

Our unique track is high in strength and low in weight. The inner rolling surface stays clean, providing lower rolling resistance and reduces the wear on the wheels of the trolleys and end trucks.

# LODERAIL

Amick Associates, Inc.

## Overhead Rail – Extruded Aluminum

version #2-04

Made in the U.S.A. 

## Overhead Rail – Extruded Aluminum

### General Description

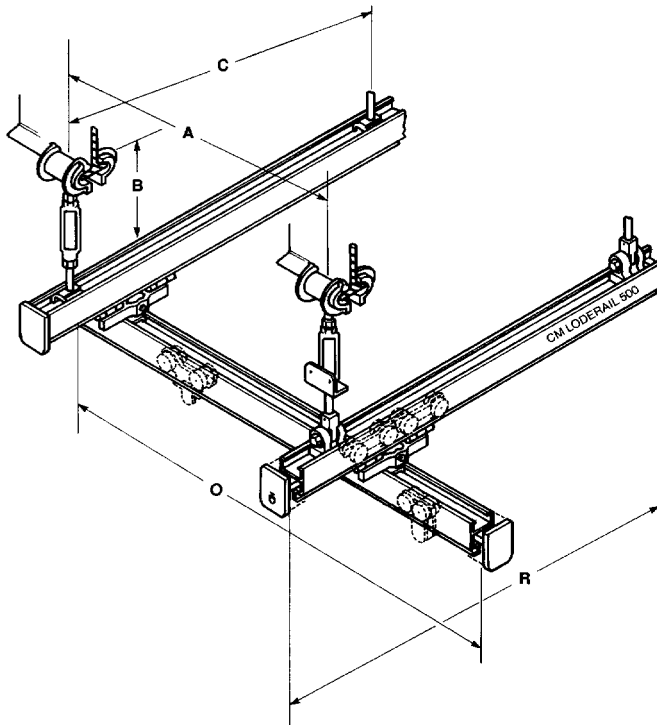
This overhead rail is ergonomically designed for:

- Ease of movement with minimum force needed to position loads.
- Corrosion resistant aluminum rail construction.
- Lightweight and easy to install.
- Pre-engineered attachments for simple installation.
- Reinforced nylon wheels for smooth, quiet operation.
- Monorail/bridge components easily adapted to application.
- Capacity: up to 1,000 lbs.
- Made in U.S.A.



### \*Warning – To avoid injury:

- Do not exceed working load limit, load rating, or capacity.
- Do not use to lift people or loads over people.
- Read and follow all instructions.



10

### Specify

- A Length of span
- B Hanger type – fixed floating length
- C Hanger centers
- O Overall bridge length
- R Runway length

### \*WARNING

Overloading and improper use can result in injury. See above.

# JIB CRANES

---

## **Abell-Howe Floor Mounted Jib Crane**

Specifications

Features

Model J-900

Model J-906FTC

## **Conco Electrified Articulated Jib Crane**

Standard Duty

Heavy Duty

Light Duty



# JIB CRANES

Amick Associates, Inc.

## Abell-Howe Floor Mounted Jib Crane

version #2-04

Made in the U.S.A. 

### Abell-Howe Floor Mounted Jib Crane

#### Specifications

**MAST:** Fabricated from heavy wall structural steel pipe with wall thickness sized to minimize deflection.

**BASE PLATE:** Large diameter base plate is reinforced with heavy steel gussets for continuous alignment and rigidity.

**HEAD SECTION:** Rigid steel plate box type with welded construction for minimum deflection between boom and mast.

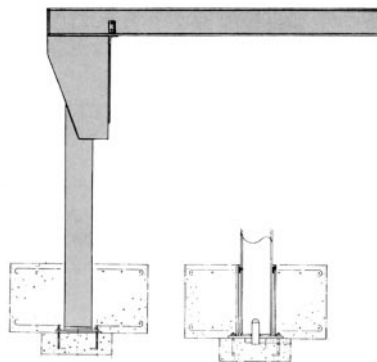
- Bottom roller assembly can be shimmed for boom leveling.

**BOOM:** Rolled steel I-beam section with long wearing tapered flange for smooth trolley travel.

- End stops at both ends of the boom are provided to limit trolley travel.

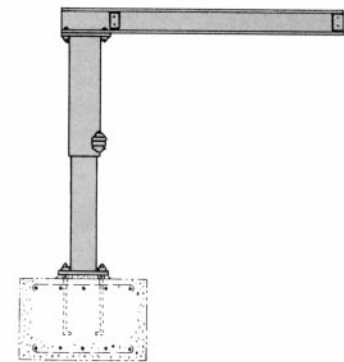
#### Features

- The J-904 boom features full 360° rotation on a tapered roller bearing providing full capacity vertical and radial thrust loading.
- The lower section of the head revolves around the pillar on a pair of steel rollers equipped with self-aligning roller bearings.
- Available in hand push, hand geared rotation, air or electric motor drives.
- J-904 Pillar Jib Cranes are available as standard in capacities from 500 to 20,000 lbs., spans to 30 feet and under boom height from 8 to 30 ft.
- Larger capacity and special configurations are available upon request.



**Model J-904F Foundation Pillar Jib Crane**

Features 360° rotation.  
Mast is mounted in concrete foundation.  
Removable sleeve is also available.



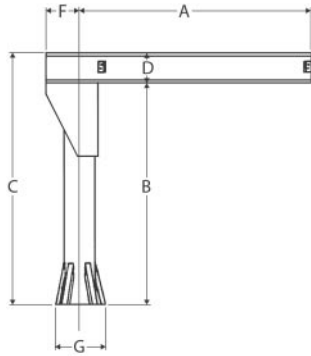
**Light-Duty  
Model J-904S Foundation-Mount  
Pillar Jib Crane  
1/2 Ton Maximum Capacity**

#### \*Warning – To avoid injury:

- Do not exceed working load limit, load rating, or capacity.
- Do not use to lift people or loads over people.
- Use only alloy chain for overhead lifting.
- Read and follow all instructions.

#### \*WARNING

Overloading and improper use can result in injury. See above.

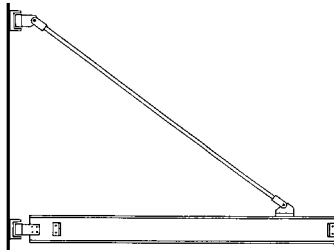


**Table 11-1. Sample of J-904 Sizes and Capacities**

Capacity (tons)	Span A	Boom Height B	Overall Height C	Model Number J904	Mast Diameter (in.)	Boom Size D	Base Plate Diameter G	Base Plate Diameter F	Approx. Net Weight (lbs.)
1/2	10'0"	10'0"	10'6"	120-06B	12-3/4	6"/12.5#	3'0"	1'3"	1,040
	12'0"	10'0"	10'7"	120-07B	12-3/4	7"/15.3#	3'0"	1'3"	1,265
	14'0"	10'0"	10'8"	120-08B	12-3/4	8"/18.4#	3'0"	1'3"	1,350
	16'0"	10'0"	10'10"	120-10B	12-3/4	10"/25.4#	3'0"	1'3"	1,515
	18'0"	10'0"	10'10"	120-10B	12-3/4	10"/25.4#	3'0"	1'3"	1,565
	20'0"	10'0"	11'0"	140-12B	14	12"/31.8#	3'6"	1'5"	2,055
1	10'0"	10'0"	10'8"	120-08B	12-3/4	8"/18.4#	3'0"	1'3"	1,280
	12'0"	10'0"	10'10"	120-10B	12-3/4	10"/25.4#	3'0"	1'3"	1,415
	14'0"	10'0"	11'0"	140-12B	14	12"/31.8#	3'6"	1'5"	1,855
	16'0"	10'0"	11'0"	140-12B	14	12"/31.8#	3'6"	1'5"	1,920
	18'0"	10'0"	11'3"	140-15B	14	15"/42.9#	3'6"	1'5"	2,205
	20'0"	10'0"	11'3"	140-15B	14	15"/42.9#	3'6"	1'5"	2,290
2	10'0"	12'0"	13'0"	140-12B	14	12"/31.8#	3'6"	1'5"	1,825
	12'0"	12'0"	13'0"	160-12B	16	12"/31.8#	4'0"	1'4-3/8"	2,440
	14'0"	12'0"	13'3"	160-15B	16	15"/42.9#	4'0"	1'4-3/8"	2,690
	16'0"	12'0"	13'6"	160-18B	16	18"/54.7#	4'0"	1'4-3/8"	2,990
	18'0"	12'0"	13'6"	180-18B	18	18"/54.7#	4'6"	1'5-3/8"	3,455
	20'0"	12'0"	13'6"	180-18B	18	18"/54.7#	4'6"	1'5-3/8"	3,585
3	10'0"	12'0"	13'3"	160-15B	16	15"/42.9#	4'0"	1'4-3/8"	2,515
	12'0"	12'0"	13'3"	180-15B	18	15"/42.9#	4'6"	1'5-3/8"	2,955
	14'0"	12'0"	13'6"	180-18B	18	18"/54.7#	4'6"	1'5-3/8"	3,235
	16'0"	12'0"	13'6"	200-18B	20	18"/54.7#	5'0"	1'8-3/8"	3,900
	18'0"	12'0"	13'8"	200-20B	20	20"/65.4#	5'0"	1'4-3/8"	4,240
	20'0"	12'0"	14'0"	240-24B	24	24"/79.9#	5'6"	1'11-1/8"	5,320
5	10'0"	12'0"	13'6"	200-18B	20	18"/54.7#	5'0"	1'8-3/8"	3,570
	12'0"	12'0"	13'6"	240-18B	24	18"/54.7#	5'6"	1'11-1/8"	4,230
	14'0"	12'0"	13'8"	240-20B	24	20"/65.4#	5'6"	1'11-1/8"	4,520
	16'0"	12'0"	14'0"	240-24B	24	24"/79.9#	5'6"	1'11-1/8"	4,960
	18'0"	12'0"	14'0"	300-24HB	30	24"/105.9#	6'0"	2'2"	7,180
	20'0"	12'0"	14'0"	300-24HB	30	24"/105.9#	6'0"	2'2"	7,390

### Model J-900

Thru 5 ton Standard capacity 200° maximum rotation.①

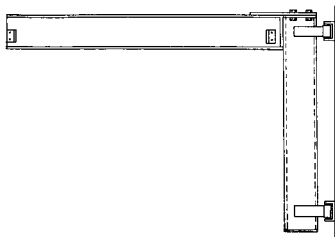


#### Specifications

- Fabricated, steel wall bracket fittings with bearings.
- Threaded tie rods provide take-up for boom leveling.

### Model J-906FCT

Thru 5 ton capacity, 20' spans standard for high hook lift application.①



#### Specifications

- Conservably designed mast resists torsional forces from off-center loading.
- Fabricated steel hinge fittings with bearings.
- Boom is preset to compensate for deflection under load.

① Larger capacity and special configurations available.

**Note:** Kits are available to convert to wall mount.

#### Available in Motorized Versions — Consult Factory

- **Abell-Howe Wall Bracket Jib Crane Fitting**  
Make your own J-900 Jib Crane using the same quality hinge fitting used on all Abell-Howe J-900 Jibs. Kit includes Upper Tie Rod Hinges; Lower Boom Hinge; and Boom End Tie Rod Connector. For capacities of 1 to 5 tons. Complete instructions included. You provide I-beam, tie rods and assembly.
- **Abell-Howe Full Cantilever Jib Crane Fitting**  
Make your own J906FCT Jib Crane up to 2 ton capacity.



#### \*Warning – To avoid injury:

- Do not exceed working load limit, load rating, or capacity.
- Do not use to lift people or loads over people.
- Use only alloy chain for overhead lifting.
- Read and follow all instructions.



**WARNING**

Overloading and improper use can result in injury. See above.

# JIB CRANES

Amick Associates, Inc.

## Conco Electrified Articulated Jib Crane

version #2-04

Made in the U.S.A. 

### Conco Electrified Articulated Jib Crane

Offers operators the lateral maneuverability of an articulated jib arm with the added flexibility provided by a prewired electric supply. This new jib arm features:

- Two 360° pivot arms that can reach and operate in confined areas where standard jib cranes cannot.
- Ease of movement and accurate positioning assured with heavy roller bearings in both arms.
- Unique electrification includes installed conductor wire and electric plugs which allow operator to easily add electric hoists such as the Lodestar hoist (hoist not included).
- Versatile as a floor or overhead mounted unit.
- More options for efficient, ergonomic operation in tight spaces or where headroom limitations rule out use of conventional straight armed jibs.
- Capacities to one ton and work envelopes to 32 feet in diameter.
- One-year warranty.
- Made in U.S.A.

**\*Warning – To avoid injury:**

- Do not exceed working load limit, load rating, or capacity.
- Do not use to lift people or loads over people.
- Use only alloy chain for overhead lifting.
- Read and follow all instructions.

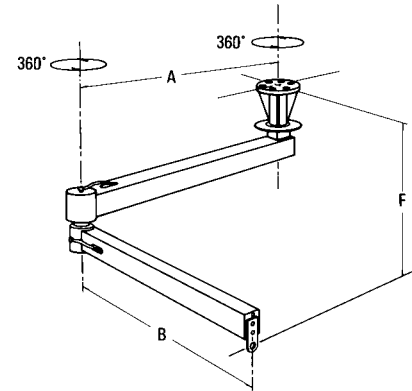


**Table 11-2. Standard Duty Electrified Articulated Jib Crane Specifications**

Model Number	Capacity <sup>①</sup> (lbs.)	Reach (ft.)	A (in.)	B (in.)	C (in.)	D (in.)	E (in.)	F (in.)
EAJ1250-8P	1,250	8	56	40	6-1/4	124-1/2	98	31-5/8
EAJ1110-9P	1,110	9	63	45	6-1/4	124-1/2	98	31-5/8
EAJ1000-10P	1,000	10	70	50	6-1/4	124-1/2	98	31-5/8
EAJ910-11P	910	11	77	55	6-1/4	124-1/2	98	31-5/8
EAJ835-12P	835	12	84	60	6-1/4	124-1/2	98	31-5/8
EAJ770-13P	770	13	91	65	6-1/4	124-1/2	98	31-5/8
EAJ715-14P	715	14	98	70	6-1/4	124-1/2	98	31-5/8
EAJ665-15P	665	15	105	75	6-1/4	124-1/2	98	31-5/8

**Note:** To convert to ceiling mount, change suffix on model to C.

<sup>①</sup> Include hoist weight to determine capacity.

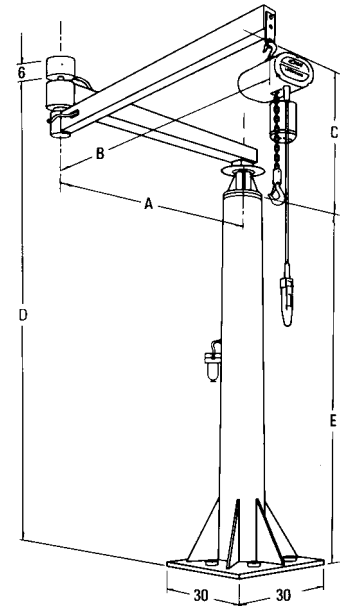


**Table 11-3. Heavy Duty Electrified Articulated Jib Crane Specifications**

Model Number	Capacity <sup>①</sup> (lbs.)	Reach (ft.)	A (in.)	B (in.)	C (in.)	D (in.)	E (in.)	F (in.)
EAJ2000-8P	2,000	8	56	40	11-3/4	134-1/2	98	44-1/2
EAJ1785-9P	1,785	9	63	45	11-3/4	134-1/2	98	44-1/2
EAJ1600-10P	1,600	10	70	50	11-3/4	134-1/2	98	44-1/2
EAJ1460-11P	1,460	11	77	55	11-3/4	134-1/2	98	44-1/2
EAJ1340-12P	1,340	12	84	60	11-3/4	134-1/2	98	44-1/2
EAJ1256-13P	1,256	13	91	65	11-3/4	134-1/2	98	44-1/2
EAJ1150-14P	1,150	14	98	70	11-3/4	134-1/2	98	44-1/2
EAJ1071-15P	1,071	15	105	75	11-3/4	134-1/2	98	44-1/2
EAJ1000-16P	1,000	16	112	80	11-3/4	134-1/2	98	44-1/2

**Note:** To convert to ceiling mount, change suffix on model to C.

<sup>①</sup> Include hoist weight to determine capacity.



**Table 11-4. Light Duty Electrified Articulated Jib Crane Specifications**

Model Number	Capacity <sup>①</sup> (lbs.)	Reach (ft.)	A (in.)	B (in.)	C (in.)	D (in.)	E (in.)	F (in.)
EAJ310-8P	310	8	56	40	3-7/8	106-1/4	90	18-1/8
EAJ280-9P	280	9	63	45	3-7/8	106-1/4	90	18-1/8
EAJ250-10P	250	10	70	50	3-7/8	106-1/4	90	18-1/8
EAJ230-11P	230	11	77	55	3-7/8	106-1/4	90	18-1/8
EAJ210-12P	210	12	84	60	3-7/8	106-1/4	90	18-1/8
EAJ190-13P	190	13	91	65	3-7/8	106-1/4	90	18-1/8
EAJ180-14P	180	14	98	70	3-7/8	106-1/4	90	18-1/8
EAJ170-15P	170	15	105	75	3-7/8	106-1/4	90	18-1/8

**Note:** To convert to ceiling mount, change suffix on model to C.

<sup>①</sup> Include hoist weight to determine capacity.

**\*Warning – To avoid injury:**

- Do not exceed working load limit, load rating, or capacity.
- Do not use to lift people or loads over people.
- Use only alloy chain for overhead lifting.
- Read and follow all instructions.

**\*WARNING** Overloading and improper use can result in injury. See above.

*This Page Intentionally Left Blank*

# LIFTING BEAMS & C-HOOKS

---

## **Standard Beams**

- Low Headroom Beams with Movable Hooks
- Optional Higher Lift Hooks
- Low Headroom Beams with Fixed Hooks
- Optional Roll Hooks

## **Two Hoist Beams**

- Team Two Cranes for Heavy Loads

## **Multi-Purpose Lifting Beams**

- Specifications
- Options
- Multi-Purpose Lifting Beam Special Features

## **Coil Lifters**

- Vertical Coil Lifters
- Tubular C-Hooks
- Narrow Aisle Coil Hooks
- Telescoping Horizontal Coil Lifters

## **Compact C-Hooks**

## **Telescoping Sheet Lifters**

- Unique Cady Sheet Lifting Features



# LIFTING BEAMS & C-HOOKS

Amick Associates, Inc.

## Standard Beams

version #8-18

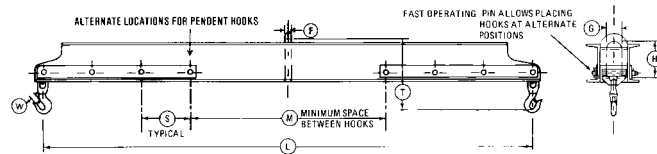


Made in the U.S.A.

## Standard Beams

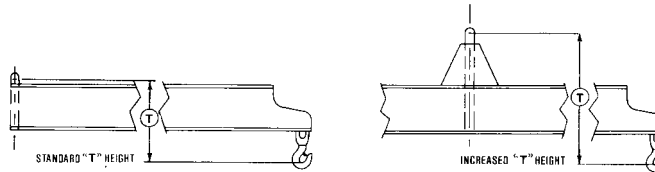
### Low Headroom Beams with Movable Hooks

- Load support hooks easily moved to accommodate various length loads.
- Hooks held with quick release pins.
- Oversized alloy swivel hooks allow side loading 26° from vertical.
- Capacity to 100 tons.
- Lengths to 50 feet.
- Made in U.S.A.



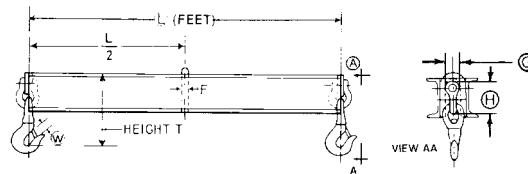
### Optional Higher Lift Hooks

- Reduces gyrating or rocking of loads.
- Standard height "T" lets you gain full advantage of available crane headroom.



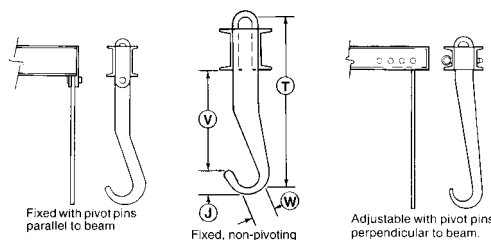
### Low Headroom Beams with Fixed Hooks

- Wide set channels allow crane hook to be lowered between the channels for minimum headroom applications.
- Other beam sizes, capacities, lengths and hooks available.
- Capacity to 100 tons.
- Lengths to 50 feet.
- Made in U.S.A.



### Optional Roll Hooks

- Roll hooks available for beams of any size.
- Available as fixed or adjustable.

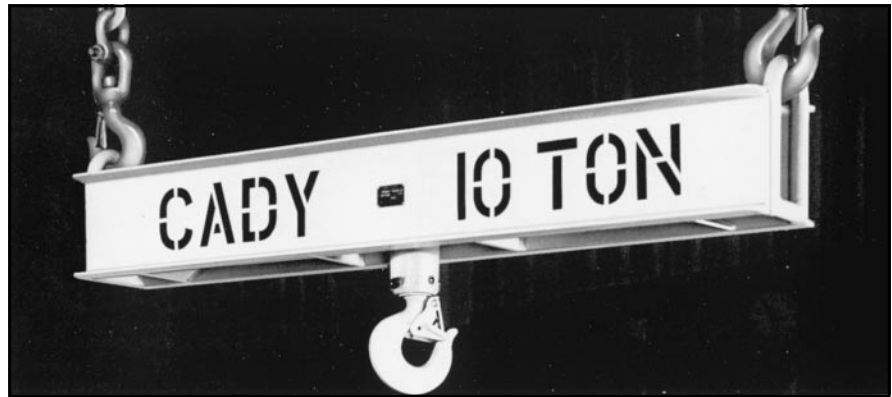




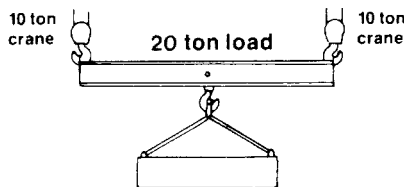
## Two Hoist Beams

### Team Two Cranes for Heavy Loads

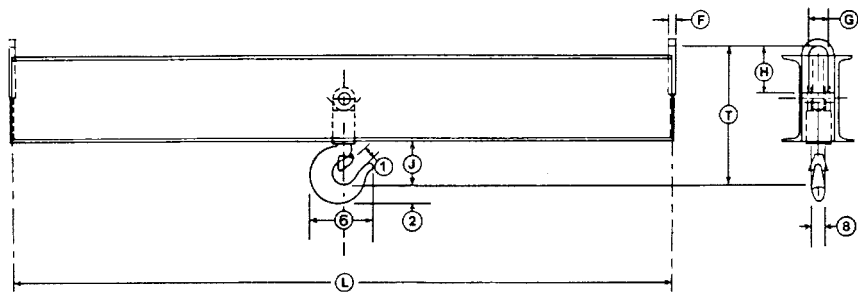
- Designed with sufficient lateral stability to prevent web buckling.
  - Load tested to twice rated load capacity.
  - Load turns freely to allow easy shipping or positioning.
  - Hook is pivoted to prevent binding as beam is raised or lowered.
  - Beam can be custom-designed to allow use of two cranes of uneven capacity.
  - Minimum beam weight allows maximum hoist rated load capacity.
- CAUTION: Total capacity of the two hoists must be down rated by the beam weight when calculating the maximum useful load capacity.
- Capacity to 75 tons.
  - Made in U.S.A.



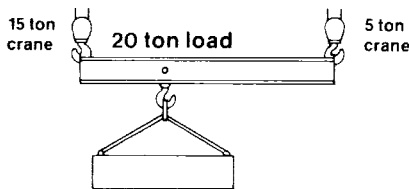
### Standard Configuration



**Team Two Cranes of Equal Capacity**



### Special Configuration



**Custom Beam Design Allows Teaming Two Cranes of Unequal Capacity**



**Two Hooks or Shackles can be Provided Below the Beam in Fixed Position or Movable as Shown**

### \* WARNING

Overloading and improper use can result in injury. See page 12-8.

# LIFTING BEAMS & C-HOOKS

Amick Associates, Inc.

## Multi-Purpose Lifting Beams

version #8-18



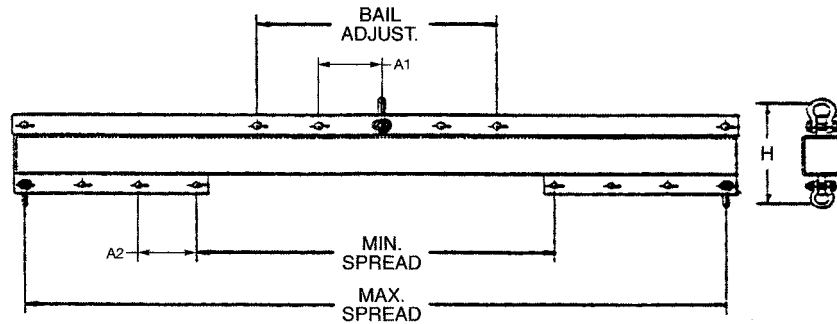
Made in the U.S.A.

### Multi-Purpose Lifting Beams

- Designed for heavy industrial use.
- Adjustable lower lift points.
- Handles unbalanced loads by adjusting center lift point.
- Lower and upper shackles included, additional rigging can be added.
- Structural tube construction.
- All welded construction (not bolted together).
- All welds per AWS D1.1-98.
- Critical welds are dye penetrant tested.
- Lifter meets ANSI/ASME B30.20.
- Painted lead-free safety yellow.
- Proof tested at two times capacity and certified.
- Made in the U.S.A.
- Fast delivery.

**Table 12-1. Multi-Purpose Lifting Beam Specifications**

Model	Capacity (lbs.)	Maximum Spread (in.)	Minimum Spread (in.)	Bail Adj. (in.)	A1 (in.)	A2 (in.)	Head Room (in.)	CM Bolt Type Anchor Shackle		Weight (lbs.)
								Lower (tons)	Upper (tons)	
MPV-4	500	48	12	16	4	6	8-3/8	3-1/3	3-1/3	70
MP2-6	2,000	72	36	24	6	6	11-3/4	3-1/3	5	150
MP4-6	4,000	72	36	24	6	6	13-1/4	3-1/3	5	171
MP8-8	8,000	96	48	36	6	6	17-3/8	5	7	333
MP10-10	10,000	120	60	40	4	6	17-3/8	5	7	450
MP14-12	14,000	144	72	48	6	6	24	7	9-1/2	738



### Options

- **Part Number: CMP10CBA**  
Cross beams for 500 to 4000 lbs. capacity multi-purpose beams. 48" shackle centers, adjusts to 36", 24" and 12" centers.
- **Part Number: CMP18CB**  
Cross beams for 8000 lbs. capacity multi-purpose beams same shackle centers as above.
- **The cross beams for MP10-10 and MP14-12 will be made to customers' specifications.**

12

### \* WARNING

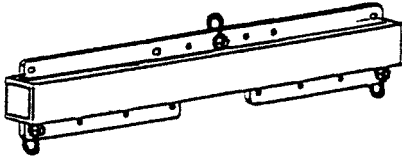
Overloading and improper use can result in injury. See page 12-8.



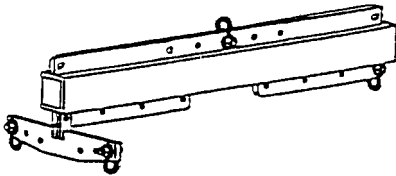
Made in the U.S.A. 

### Multi-Purpose Beam Special Features

#### 2-Point Lifter

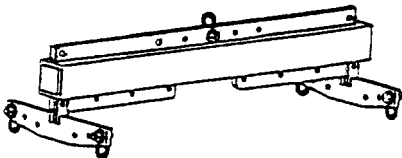


#### 3-Point Lifter



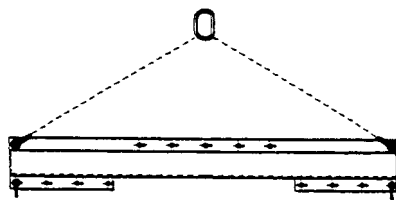
- Standard or custom lower accessory cross beams attach to any lower shackle holes.

#### 4-Point Lifter



- Standard or custom lower accessory cross beams attach to any lower shackle holes.
- Convenient for handling super sacks or bulk bags.

#### Spreader Beam

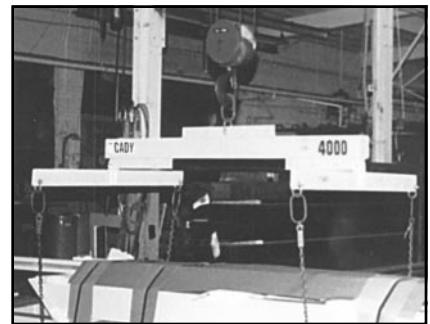
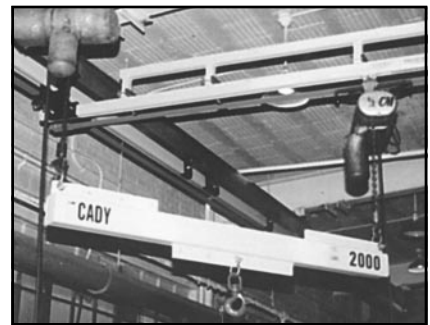


- 3/8 Herc Alloy top chain sling adds additional stability.
- 1 and 2 ton beams have 72" spread.

#### Two Hoist Beam



- Allows for a more stable lift for unbalanced loads.



**WARNING**

Overloading and improper use can result in injury. See page 12-8.

# LIFTING BEAMS & C-HOOKS

Amick Associates, Inc.

## Coil Lifters

version #8-18

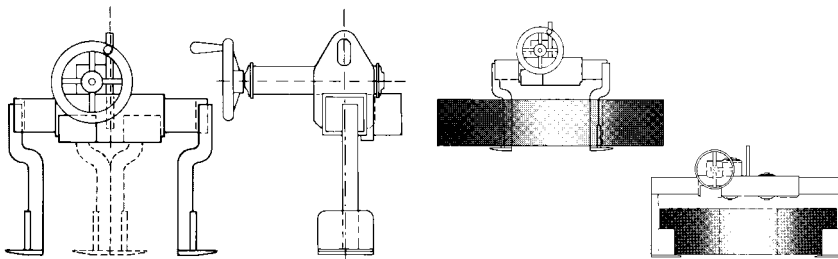
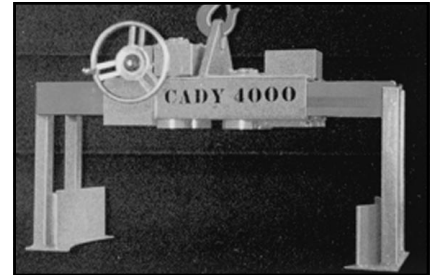


Made in the U.S.A. 

## Coil Lifters

### Vertical Coil Lifters

- Variety of lifters available for handling coils in vertical position.
- To be effective all coils must be tightly wound on tensioning device before handling.
- Capacity to 15 tons.
- Made in U.S.A.
- Custom vertical lifters can be designed with the following information:
  - Maximum outside diameter \_\_\_\_\_
  - Minimum outside diameter \_\_\_\_\_
  - Maximum inside diameter \_\_\_\_\_
  - Minimum inside diameter \_\_\_\_\_
  - Coil width range \_\_\_\_\_
  - Stack height \_\_\_\_\_
  - Clearance between coils/coils and pallet \_\_\_\_\_

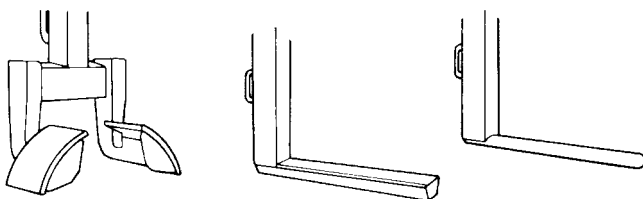
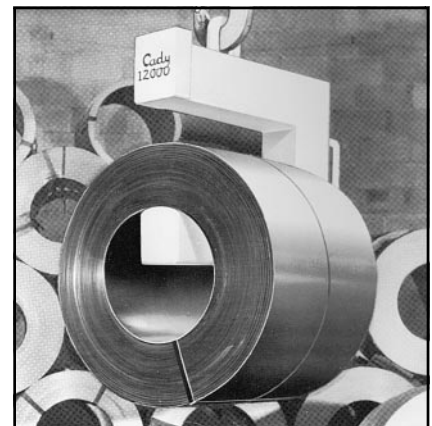


### Tubular C-Hooks

- Made from internally stiffened structural tubes.
- Provides less expensive alternative to compact alloy C-hooks under 20,000 lb. capacity.
- Any coil width.
- Special lifting arms can be custom designed.
- Capacity to 15 tons.
- Made in U.S.A.

### Special Lifting Arms

Tubular C-hooks can be furnished with specially shaped lifting arms to meet your requirements. Exact I.D. dimensions are required for quote.



12

### \* WARNING

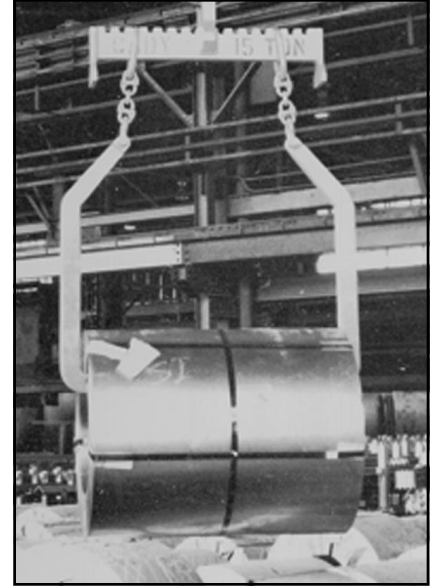
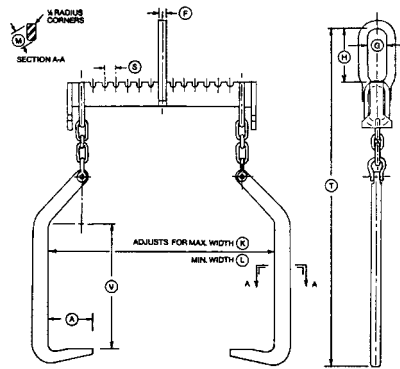
Overloading and improper use can result in injury. See page 12-8.



Made in the U.S.A.

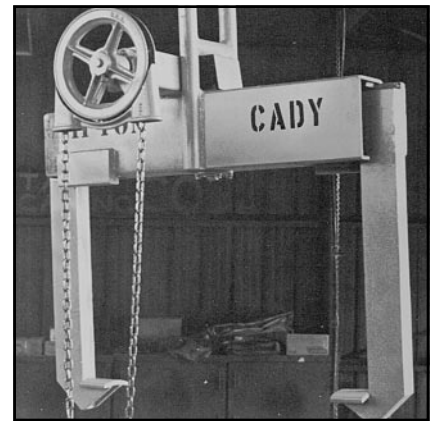
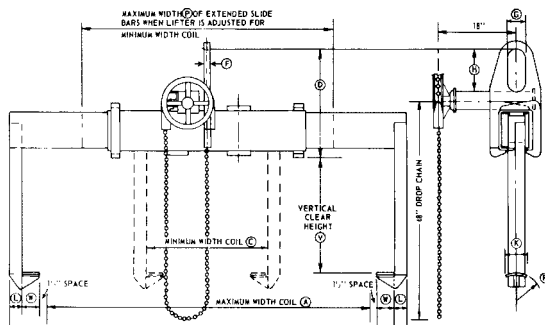
## Narrow Aisle Coil Hooks

- Low cost, low maintenance solution for narrow aisle coil handling.
- Allows operator to automatically hook and release coils from remote crane.
- Function easily with 12" to 16" aisles.
- Notched upper beam allows easy adjustments.
- Made from quenched and tempered alloy steel.
- Custom fit bail minimizes wear.
- Capacity to 40 tons.
- Made in U.S.A.



## Telescoping Horizontal Coil Lifters

- Two-sided telescoping coil lifters handle range of coil sizes.
- Stores coils with minimum space between rows.
- Telescoping width adjustment by self-locking worm gear drive.
- All shafts ball bearing mounted.
- Slip-clutch prevents gear damage.
- Easy manual chain-wheel operation.
- Pushbutton motor drive or remote control available.
- Capacity to 40 tons.
- Made in U.S.A.



**\*WARNING**

Overloading and improper use can result in injury. See page 12-8.

# LIFTING BEAMS & C-HOOKS

Amick Associates, Inc.

## Compact C-Hooks

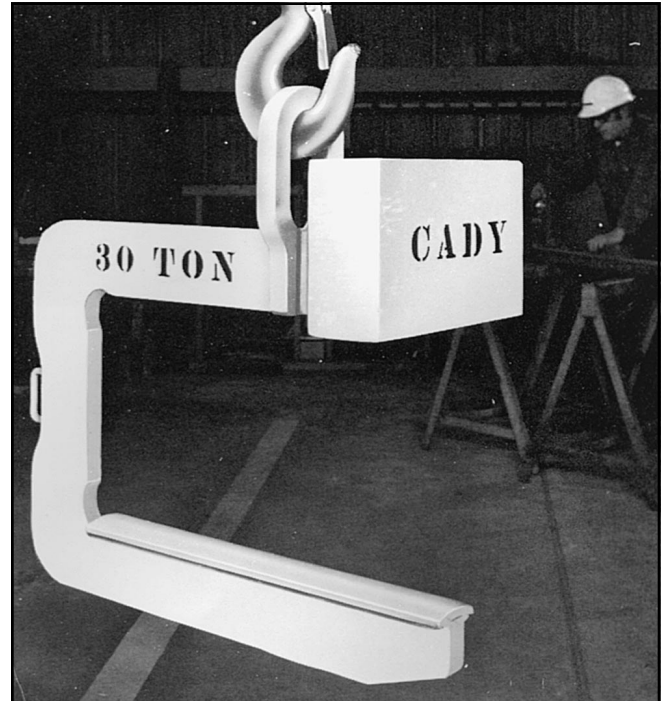
version #8-18



Made in the U.S.A. 

## Compact C-Hooks

- Three types (close stacker, low cost and slit coil).
  - High-strength quenched and tempered T-1<sup>Ⓢ</sup> alloy steel.
  - Rugged, lightweight and 2 to 3 times more resistant to bending than carbon steel.
  - Low tare weight reduces wear and tear on crane coils.
  - Large radial corners minimize stress and reduce coil damage.
  - Curved saddles prevent coil damage.
  - Counterbalanced to hang level when empty.
  - Centered under bail for proper balance.
  - Capacity 100 lbs. to 50 tons.
  - Made in U.S.A.
- Ⓢ T-1 is a trademark of U.S. Steel Corp.



### \*Warning – To avoid injury:

- Inspect lifter, moving lifter parts and operating controls for proper operation before each use. Never use malfunctioning or damaged filter, or one tagged “Out of Service.”
- Do not exceed rated load of lifter and crane.
- Make sure load is balanced and stable.
- Avoid shock loads due to sudden starts and stops.
- Make sure lifting ropes and chains are not twisted or kinked.
- Do not lift people. Make sure operator and others are clear of load at all times.
- Make sure load clears objects during moving.



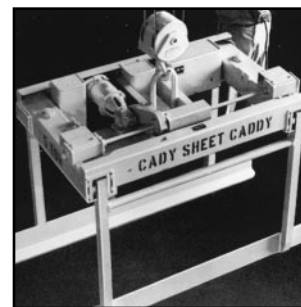
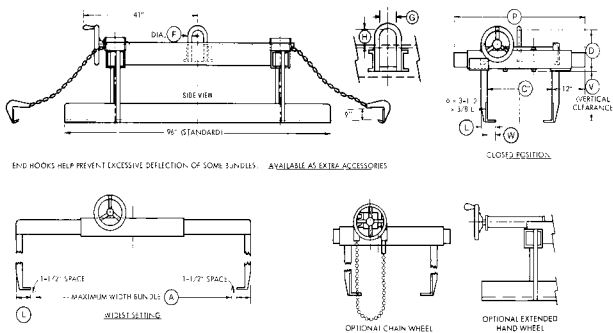
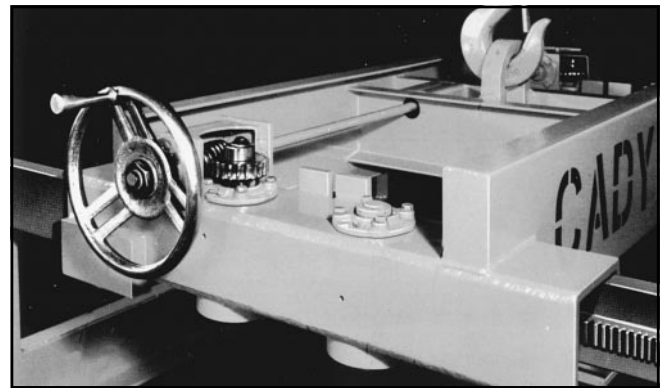
Made in the U.S.A.

### Telescoping Sheet Lifters

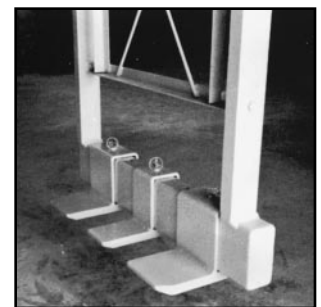
- Telescoping design allows efficient low headroom, low-maintenance sheet handling.
- Handles sheet bundles, plate, wallboard and plywood.
- Can be modified for use with palletized coils, crates and tote boxes.
- Saves aisle space.
- Self-locking worm gear drive prevents support legs from opening.
- Made in U.S.A.
- Accessories available as extras include:
  - Motor drive option with pendant or remote control.
  - Longer or shorter side angles available.
  - Longer or shorter legs available.
  - Can opt for chain wheel with chain loop instead of hand wheel.
  - Extended hand or chain wheel.
  - Supporting end chains and hooks.
  - Capacity to 25 tons.
  - Bundle widths to 12 feet.

### Unique Cady Sheet Lifting Features

- Bronze worm gears with protective cover for added safety.
- Torque limiter in hand wheel protects gears.
- Load tested at full extension.
- T-1 alloy bail is 2 to 3 times more wear resistant than low carbon steel.
- Ball bearings on all shafts.
- Self-locking worm gear drive prevents support legs from opening.
- Motor drive option allows higher stacking with easy pushbutton operation.
- Adjustable finger support option allows handling of sheets strapped to packing materials.



Motor Drive Option



Finger Support Option

**\* WARNING** Overloading and improper use can result in injury. See page 12-8.

# LIFTING BEAMS & C-HOOKS

*Amick Associates, Inc.*

version #8-18

*This Page Intentionally Left Blank*

# FALL PROTECTION

---

## **SafeWaze®**

- AirFlex® Ultimate Safety Harness
- Ameba® Comfort Harness
- Powerstop Lanyard
- TyBak® Series
- Anchor Points
- THOR® Retractable Lifelines
- Permanent Horizontal Systems
- Ideal Lifeline® with PowerBrake
- Roofing

## **Miller®**

---



13

# FALL PROTECTION

Amick Associates, Inc.

## AirFlex® Ultimate Safety Harness

version #2-04

**SAFEMAZE®**

Made in the U.S.A. 

### AirFlex® Ultimate Safety Harness

The ultimate harness to satisfy all your fall protection needs. With state-of-the-art Ameba® Webbing, a design using helical yarns that enables webbing expansion, the AirFlex enhances comfort and ease of body movement providing an optimum fit regardless of your size or shape. The AirFlex incorporates air flow material, providing ventilation that keeps moisture away from the body. The unique design incorporates built-in shoulder pads, as well as padding for the hips and legs, ensuring tangle-free comfort without sacrificing safety. When looking for a top-of-the-line safety harness, the AirFlex Deluxe Safety Harness is the only choice.

#1510



#1510

- Back D-Ring.
- Quick connect buckles.
- Non-slip padding.
- No tangle design.
- Ameba webbing.
- Fall arrest.

#1511



#1511

- Back D-Ring.
- Waist D-Rings, with back support pad.
- Quick connect buckles.
- Non-slip padding.
- No tangle.



Made in the U.S.A. 

### Ameba® Comfort Harness

#### "Moves As You Move"

Ergonomically designed for the professional, the Ameba harness adds comfort and mobility to increase worker performance, as well as safety. The Ameba design, incorporating helical yarn configurations, allows for additional movement without the risk of harness contortion due to an over stretch design. The Ameba comfort harness is the SAFE choice for increased flexibility.

#### Ameba Harness



*Ameba Harness*

#### AMEBA1410

- Harness moves as you move.
- Includes quick connect buckles.
- Fall arrest.

#### AMEBA1411

- Same as 1410 with 2 waist D-Rings.
- Fall arrest, positioning.
- Sizes: Universal.

#### Ameba Plus Harness



*Ameba Plus Harness*

#### AMEBA1450

- Harness moves as you move.
- Includes grommet leg straps.
- Fall arrest.

#### AMEBA1451

- Same as 1450 with grommet leg straps.
- Fall arrest, positioning.
- Sizes: Universal.

#### Ameba Worksafe Harness

#### AMEBA1311



*Ameba Worksafe Harness — AMEBA1311*

1. Lanyard clip.
2. Adjustable 6" back pad.
3. Grommet legs.
4. Adjustable chest strap.
5. Ameba webbing "Moves As You Move".
6. Removable tool belt.

#### Ameba Tower Harness

#### AMEBA(B)1461



*AMEBA(B)1461*

- Front, 2 side and back D-Rings.
- Seat pad and 6" back pad.
- Waist belt.

#### AMEBA1461



*AMEBA1461*

- Front, 2 side and back D-Rings.
- 6" back pad.
- Waist belt.

#### AMEBA(B)1311



*AMEBA(B)1311*

- 2 side and back D-Rings.
- 6" back pad.
- Comfortable and convenient seat pad.
- Fall arrest, positioning.
- Sizes: S, M, L, XL.

# FALL PROTECTION

Amick Associates, Inc.

## Powerstop Lanyard and TyBak® Series

version #2-04

**SAFEMAZE®**

Made in the U.S.A. 

### Powerstop Lanyard and TyBak® Series

#### Powerstop Lanyard

##### Everest Powerstop



#3530-E

*Rated at 400 lbs.*

Shock Absorbing Lanyard which is rated for up to 400 lbs. and limits forces of a 6' fall below OSHA limits.

**Note:** Also available in Dual Leg #3530-DE.

##### Powerstop



#3530

Shock Absorbing Lanyard which limits forces of a 12' fall below OSHA limits.

**Note:** Also available in Dual Leg #3530-D.

#### TyBak Series

##### TyBak



#3560

##### TyBak #3560

Twin Leg Cross Arm Lanyard, 6' nylon web. Ideal when there is difficulty finding an anchor point. A 100% tie-off lanyard. Sliding D-Ring enables worker to connect snap hook directly into itself, eliminating an additional anchor component.

##### TyBak #3561

Same as #3560 with single leg.

##### TyBak II™



#3812

##### TyBak II #3812

Includes a fall rated hook which is designed to tie back into the lanyard webbing. The gate opening is rated at 6000 lbs.

- 6000 lb. Twist Lock Snaphook
- 12,500 lb. Omega® webbing.
- Abrasion resistant webbing.
- Webbing indicator tracers.

##### TyBak II #3813

Same as #3812 with dual leg.



Made in the U.S.A. 

### Anchor Points

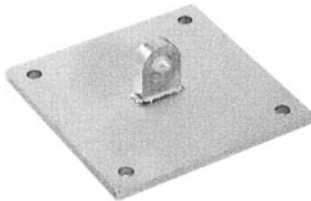
#### D-Bolt Anchor



#4005

Anchor system with a 1/2" diameter bolt. The D-Bolt's anti-rollout feature is ideal for an attachment point.

#### Base Plate Anchor



SWPC-01

Provides a permanent anchorage point as it bolts to the beam or column.

#### Swivel Anchor



#4003

Provides a permanent anchorage point as it bolts to the beam or column.

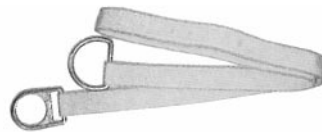
#### D-Plate Anchor



#4004

Provides a permanent anchorage point as it bolts to the beam or column.

#### 6' Cross Arm Strap



#4550

6' cross arm strap with 1-3/4" webbing.

#### Cross Arm Strap



#4550-U

Manufactured from 1-3/4" and 3" webbing, the Cross Arm Strap is designed to wrap around structures, forming a secure anchor point. Standard 6' with other lengths available.

#### Adjustable Cross Arm Strap



#4550-A

Convenient Cross Arm Strap ideally suited for quick installation. Adjustable feature ensures handling all applications. Adjusts from 2' to 6'.

#### 6' Cable Pass-thru Cross Arm Strap



#4550-SCS-6

Available in 4' also.

#### Scaffold Anchorage



#4551

Cross Arm Strap for scaffolding. 18" long, fits 3" maximum structure.

# FALL PROTECTION

Amick Associates, Inc.

## THOR® Retractable Lifelines

version #2-04

**SAFETY WAZE®**

Made in the U.S.A. 

## THOR® Retractable Lifelines

### THOR-LITE



**THOR-LITE**

**Table 13-1. THOR-LITE**

Item #	Length (ft.)	Weight (lbs.)
MS108	8	4

**Note:** All THOR-MINI Retractable Lifelines include swivel snap hook with impact indicator and carabiner.

### THOR WEB Retractable



**THOR WEB Retractable**

**Table 13-2. THOR WEB Retractable**

Item #	Length (ft.)	Weight (lbs.)
3315	15	9
3320	20	10
3325	25	11
3330-1	30	12
3340	40	15

**Note:** Includes swivel snap hook with impact indicator and carabiner.

### THOR-MINI Swivel Handle

The THOR-MINI Swivel Handle Retractable Lifelines incorporate the rugged THOR quality with a unique swivel handle to ensure ease of movement.



**THOR-MINI Swivel Handle**

**Table 13-3. THOR-MINI Swivel Handle**

Item #	Length (ft.)	Weight (lbs.)
MS111	11	4 (web)
MS112	11	6 (cable)

**Note:** All THOR-MINI Retractable Lifelines include swivel snap hook with impact indicator and carabiner.

### THOR-MINI Cable



**THOR-MINI Cable**

**Table 13-4. THOR-MINI Cable**

Item #	Length (ft.)	Weight (lbs.)
MS120	20	9

**Note:** All THOR-MINI Retractable Lifelines include swivel snap hook with impact indicator and carabiner.



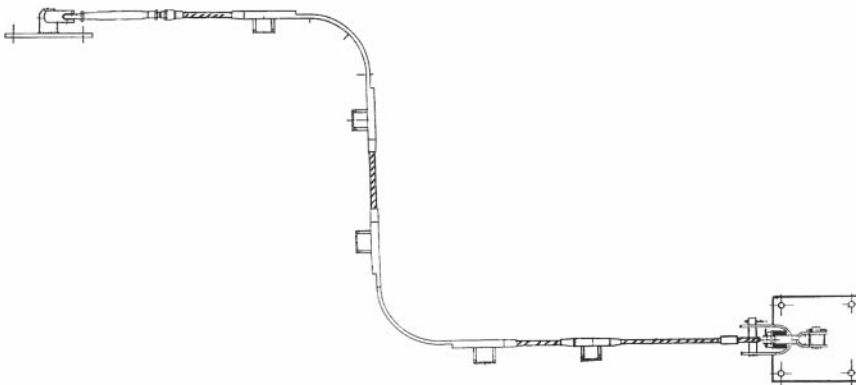
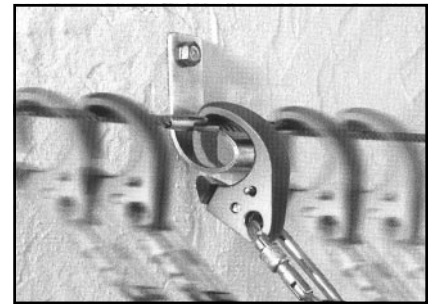
Made in the U.S.A. 

### Permanent Horizontal Systems

#### SkyWalk® Permanent Cable Lifeline

The SkyWalk cable lifeline system has been devised to allow the user to move along a horizontal axis in complete safety. The SkyWalk is designed to enter or exit the system at any point by means of a simple manual operation. The construction of the SkyWalk system allows the user to pass on intermediate brackets without disconnecting the connection. The intermediate brackets are designed to progressively deform during a fall, dispersing a portion of the force.

The SkyWalk system has a wide variety of intermediate brackets for various installation applications. Each of these allow the user to pass an intermediate bracket without disconnecting the connection. The system design allows for turns of 0° to 90°.



# FALL PROTECTION

Amick Associates, Inc.

## Ideal Lifeline® with PowerBrake

version #2-04

**SAFEWAZE®**

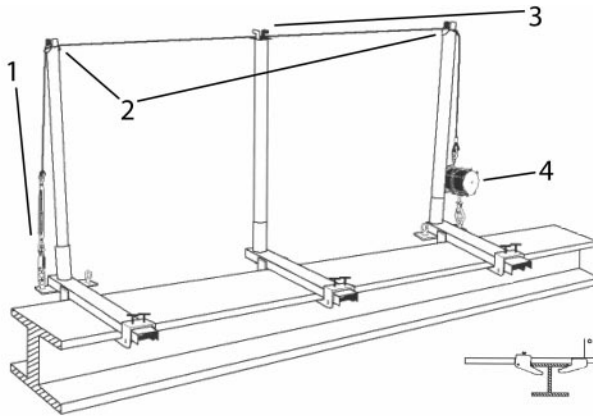
Made in the U.S.A. 

### Ideal Lifeline® with PowerBrake

#### Engineered 4-Man Horizontal Lifeline System

The Ideal Lifeline System is an engineered 4-man horizontal lifeline system that utilizes the exclusive SafeWaze PowerBrake shock absorbing system. Quick and easy to install.

Shock absorbing system permits 4 workers to be tied off in a single span or for a total system.



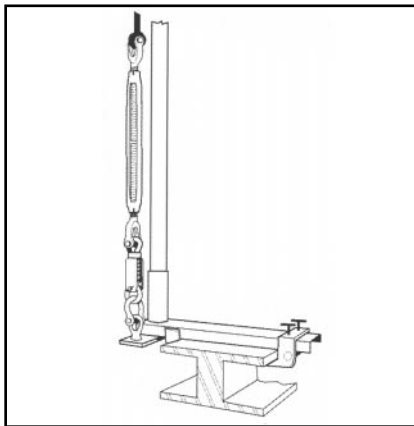
*I-Beam Stanchion Side View*

#### Ideal Lifeline Component Part Numbers:

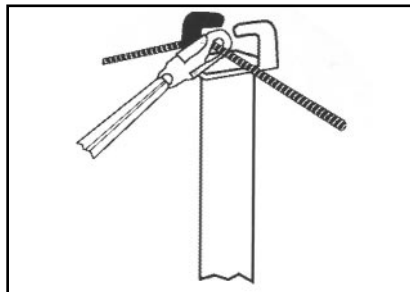
- SWPC17 — Pretension Bracket
- SWPC18 — PowerBrake
- SWID03 — Shackle
- SWID04 — Turnbuckle
- 0210 — Carabiner

**Table 13-5. Flange Limitations**

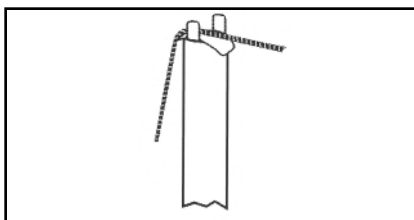
Part #	Flange Thickness (in.)	Beam Width (in.)
SP-3	Up to 1-3/8	6 to 20
SP-3A	Up to 1-3/8	6 to 20
SP-4	Up to 2-1/2	9 to 30
SP-4A	Up to 2-1/2	9 to 30



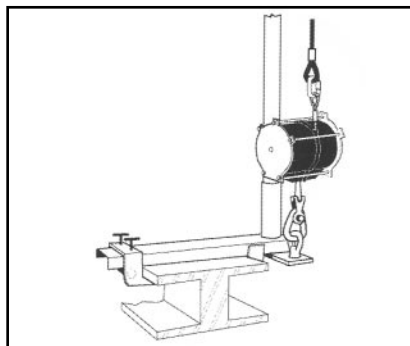
1. Turnbuckle and Pretension Bracket attached to support base with shackle.



3. Lanyard pass-thru design enables worker to pass intermediate stanchions without disconnecting.



2. Slotted end anchor posts for cable positioning.



4. PowerBrake attached to support base with carabiner.



Made in the U.S.A. 

## Roofing

### Bucket of Safety



Bucket of Safety

#### #20000

- 10910 harness.
- 209512 shock lanyard.
- 0222-50 – 1/2".
- 0116 rope grab – 1/2".
- (2) 4651X disposable roof bracket.
- 5000 bucket.

### SafeLight® Harness



SafeLight Harness

#### #10910

- Lightweight.
- Quick release buckles.
- Single back D-Ring.

#### #10950

- With grommet legs.

### Vertical Lifelines — Lightweight and durable, Polyester covered blended rope.



Vertical Lifelines

Table 13-6. Vertical Lifelines

Item #	Length (ft.)	Thickness (in.)
0221-25	25	5/8
0221-50	50	5/8
0221-75	75	5/8
0221-100	100	5/8
0222-25	25	1/2
0222-50	50	1/2

### Rope Grabs

#### #0110



Rope Grabs — #0110

#### #0110

- Fits 5/8" rope.
- Lightweight.
- Very durable.



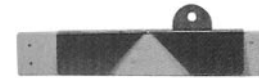
Rope Grabs — #0116

#### #0116

- Fits 1/2" rope.
- Lightweight.
- Very durable.

### TrussGrip™

#### #4652



TrussGrip — #4652

- Permanent or temporary.
- Easy to install.
- Wood framing.

### Reusable Roof Anchor

#### #4000

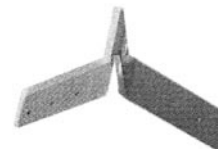


Reusable Roof Anchor — #4000

- Heavy gauge steel.
- Fits any pitch angle.
- Hinge construction.
- Reusable.

### RoofGrip™

#### #4651X



RoofGrip — #4651X

- Easy to install and use.
- No removal necessary.

# FALL PROTECTION

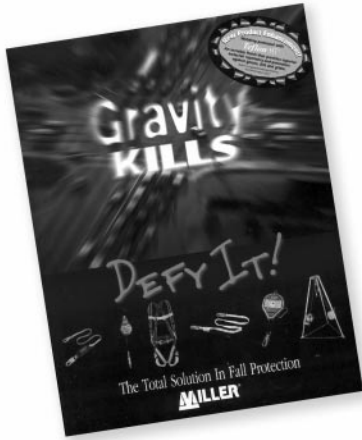
*Amick Associates, Inc.*

version #2-04



Made in the U.S.A. 

Amick Associates also offers the full line of Miller products.



# SOFT ROPE

---

## Specifications — Cordage

### 3-Strand Rope

- Spun Nylon
- Spun Polyester
- Multiline II
- Yellow Polypropylene

### Polypropylene Rope Slings

- Eye and Eye Slings
- Endless Slings



# SOFT ROPE

Amick Associates, Inc.

## Specifications — Cordage

version #2-04

### Specifications — Cordage

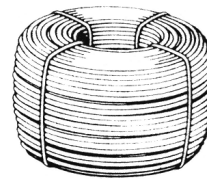
Amick Associates stocks various sizes of the following soft ropes:

- Manila
- Polyester
- Esterlene 9000

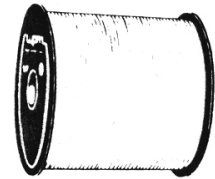
Amick Associates can fabricate slings out of your synthetic rope.



Coils



Large Coils



Spools

Table 14-1. Specifications — Cordage

Nominal Size		Manila			Nylon			Polypropylene		
Diameter	Circumference	Linear Density (lbs./100 ft.)	Minimum Tensile Strength (lbs.)	Maximum Working Load (lbs.) <sup>①</sup>	Linear Density (lbs./100 ft.)	Minimum Tensile Strength (lbs.)	Maximum Working Load (lbs.) <sup>①</sup>	Linear Density (lbs./100 ft.)	Minimum Tensile Strength (lbs.)	Maximum Working Load (lbs.) <sup>①</sup>
3/16	5/8	1.50	406	41	1.00	900	75	.70	720	72
1/4	3/4	2.00	540	54	1.50	1,490	124	1.20	1,130	113
5/16	1	2.90	900	90	2.50	2,300	192	1.80	1,710	171
3/8	1-1/8	4.10	1,220	122	3.50	3,340	278	2.80	2,440	244
7/16	1-1/4	5.25	1,580	176	5.00	4,500	410	3.80	3,160	352
1/2	1-1/2	7.50	2,380	264	6.50	5,750	525	4.70	3,780	420
9/16	1-3/4	10.4	3,100	388	8.15	7,200	720	6.10	4,600	575
5/8	2	13.3	3,960	496	10.5	9,350	935	7.50	5,600	700
3/4	2-1/4	16.7	4,860	695	14.5	12,800	1,420	10.7	7,650	1,090
13/16	2-1/2	19.5	5,850	835	17.0	15,300	1,700	12.7	8,900	1,270
7/8	2-3/4	22.4	6,950	995	20.0	18,000	2,000	15.0	10,400	1,490
1	3	27.0	8,100	1,160	26.4	22,600	2,520	18.0	12,600	1,800
1-1/16	3-1/4	31.2	9,450	1,350	29.0	26,000	2,880	20.4	14,400	2,060
1-1/8	3-1/2	36.0	10,800	1,540	34.0	29,800	3,320	23.8	16,500	2,360
1-1/4	3-3/4	41.6	12,200	1,740	40.0	33,800	3,760	27.0	18,900	2,700
1-5/16	4	47.8	13,500	1,930	45.0	38,800	4,320	30.4	21,200	3,020
1-1/2	4-1/2	60.0	16,700	2,380	55.0	47,800	5,320	38.4	26,800	3,820
1-5/8	5	74.5	20,200	2,880	66.5	58,500	6,500	47.6	32,400	4,620
1-3/4	5-1/2	89.5	23,800	3,400	83.0	70,000	7,800	59.0	38,800	5,550
2	6	108.0	28,000	4,000	95.0	83,000	9,200	69.0	46,800	6,700
2-1/8	6-1/2	125.0	32,400	4,620	109.0	95,500	10,600	80.0	55,000	7,850
2-1/4	7	146.0	37,000	5,300	129.0	113,000	12,600	92.0	62,000	8,850
2-1/2	7-1/2	167.0	41,800	5,950	149.0	126,000	14,000	107.0	72,000	10,300
2-5/8	8	191.0	46,800	6,700	168.0	146,000	16,200	120.0	81,000	11,600
2-7/8	8-1/2	215.0	52,000	7,450	189.0	162,000	18,000	137.0	91,000	13,000
3	9	242.0	57,500	8,200	210.0	180,000	20,000	153.0	103,000	14,700
3-1/4	10	298.0	69,500	9,950	264.0	226,000	25,200	190.0	123,000	17,600
3-5/8	11	366.0	82,000	11,700	312.0	270,000	30,000	232.0	146,000	20,800
4	12	434.0	94,500	13,500	380.0	324,000	36,000	276.0	171,000	24,000
4-1/4	13	—	—	—	445.0	380,000	42,200	325.0	202,000	28,900
4-1/2	14	—	—	—	520.0	441,000	49,000	375.0	234,000	33,400
5	15	—	—	—	590.0	507,000	56,300	430.0	268,000	38,300
5-1/4	16	—	—	—	675.0	572,000	63,600	490.0	302,000	43,100
5-5/8	17	—	—	—	765.0	635,000	70,600	555.0	329,000	47,000
6	18	—	—	—	860.0	698,000	77,600	625.0	360,000	51,400

① Maximum Working Loads are for rope in good condition with appropriate splices in non-critical applications, and under normal service conditions. Working loads should be reduced where life, limb, valuable property are involved, or for exceptional service conditions such as shock loads, sustained loads, etc.

**Note:** Amick splices all types of ropes.

## 3-Strand Rope

### Spun Nylon (Price Code: A)

New England Ropes 3-Strand Spun Nylon rope is manufactured from staple/spun nylon, resulting in a soft, easy to grip surface — used in safety lines and animal leads.

**Table 14-2. Specifications — Spun Nylon**

Diameter (in.)	Diameter (mm)	Weight (lbs./100 ft.)	Spool Length (ft.)	Tensile Strength	White Code	White Spool Price
3/8	9	3.3	600	2,800	8130-12	\$122.72
9/16	14	7.0	600	6,400	8130-18	\$212.16
5/8	16	8.9	600	7,800	8130-20	\$249.60

### Spun Polyester a.k.a. Spun Classic (Price Code: A)

New England Ropes 3-Strand Spun Polyester rope is manufactured from staple/spun polyester. Result is a soft easy to grip rope with a relatively low elongation.

**Table 14-3. Specifications — Spun Polyester a.k.a. Spun Classic**

Diameter (in.)	Diameter (mm)	Weight (lbs./100 ft.)	Spool Length (ft.)	Tensile Strength	White Code	White Spool Price
3/16	5	1.2	1200	700	7230-06	\$94.00
1/4	6	2.0	1200	1,200	7230-08	\$138.00
5/16	8	2.7	600	1,800	7230-10	\$99.00
3/8	9	3.8	600	2,500	7230-12	\$141.00
7/16	11	5.1	600	3,300	7230-14	\$196.00
1/2	12	7.0	600	3,800	7230-16	\$238.00
9/16	14	8.3	600	5,400	7230-18	\$318.00
5/8	16	10.3	600	6,000	7230-20	\$370.00
3/4	19	14.8	600	7,500	7230-24	\$528.00

### Multiline II (Price Code: A)

Multiline II is a 3-Strand composite rope, its unique construction combines filament and staple/spun polyester cover yarns wrapped around a polyolefin core (smaller than 1/2" diameter — does not have polyolefin core). Multiline II provides the greatest durability, highest strength, lighter weight, and consistent supple feel over time of any similar composite rope.

**Table 14-4. Specifications — Multiline II**

Diameter (in.)	Diameter (mm)	Weight (lbs./100 ft.)	Spool Length (ft.)	Tensile Strength	White Code	White Spool Price
5/16	8	2.5	600	2,300	7300-10	\$68.64
3/8	9	3.6	600	3,200	7300-12	\$91.52
7/16	11	5.0	600	4,100	7300-14	\$127.92
1/2	12	6.2	600	5,800	7300-16	\$152.88
5/8	16	9.5	600	8,200	7300-20	\$222.56
3/4	19	13.7	600	10,500	7300-24	\$310.96
7/8	22	18.0	600	15,500	7300-28	\$436.80
1	24	20.6	600	18,700	7300-32	\$490.88
1-1/8	28	30.7	600	26,000	7300-36	\$531.30

### Yellow Polypropylene (Price Code: B)

New England Ropes 3-Strand Polypropylene rope is a light and inexpensive rope that floats indefinitely. Suitable for non-critical applications. Will deteriorate in sunlight.

**Table 14-5. Specifications — Yellow Polypropylene**

Diameter (in.)	Diameter (mm)	Weight (lbs./100 ft.)	Spool Length (ft.)	Tensile Strength	Yellow Code	Yellow Spool Price
3/16	5	0.7	1200	850	7905-06	\$42.00
1/4	6	1.2	1200	1,350	7905-08	\$64.00
5/16	8	1.8	600	2,050	7905-10	\$39.00
3/8	9	2.8	600	2,900	7905-12	\$57.00
7/16	11	3.8	600	3,800	7905-14	\$76.00
1/2	12	4.5	600	4,700	7905-16	\$92.00
5/8	16	7.5	600	7,000	7905-20	\$146.00
3/4	19	10.7	600	9,400	7905-24	\$198.00

# SOFT ROPE

Amick Associates, Inc.

## Polypropylene Rope Slings

version #2-04

### Polypropylene Rope Slings

#### Eye and Eye Slings

Table 14-6. Working Load Limits — Eye and Eye Slings

Rope Diameter Nominal (in.)	Nominal Weight per 100 ft. (lbs.)	Vertical Hitch	Choker Hitch	Basket Hitch			
				Angle of Rope to Horizontal			
				90°	60°	45°	30°
				Angle of Rope to Vertical			
				0°	30°	45°	60°
1/2	4.7	645	325	1,290	1,120	910	645
9/16	6.1	780	390	1,560	1,350	1,100	780
5/8	7.5	950	475	1,900	1,650	1,340	950
3/4	10.7	1,300	650	2,600	2,250	1,840	1,300
13/16	12.7	1,520	760	3,040	2,630	2,150	1,520
7/8	15.0	1,760	880	3,520	3,050	2,490	1,760
1	18.0	2,140	1,070	4,280	3,700	3,030	2,140
1-1/16	20.4	2,450	1,230	4,900	4,240	3,460	2,450
1-1/8	23.7	2,800	1,400	5,600	4,850	3,960	2,800
1-1/4	27.0	3,210	1,610	6,420	5,560	4,540	3,210
1-5/16	30.5	3,600	1,800	7,200	6,240	5,090	3,600
1-1/2	38.5	4,540	2,270	9,080	7,860	6,420	4,540
1-5/8	47.5	5,510	2,760	11,000	9,540	7,790	5,510
1-3/4	57.0	6,580	3,290	13,200	11,400	9,300	6,580
2	69.0	7,960	3,980	15,900	13,800	11,300	7,960
2-1/8	80.0	9,330	4,670	18,700	16,200	13,200	9,330
2-1/4	92.0	10,600	5,300	21,200	18,400	15,000	10,600
2-1/2	107.0	12,200	6,100	24,400	21,100	17,300	12,200
2-5/8	120.0	13,800	6,900	27,600	23,900	19,600	13,800

#### Endless Slings

Table 14-7. Working Load Limits — Endless Slings

Rope Diameter Nominal (in.)	Nominal Weight per 100 ft. (lbs.)	Vertical Hitch	Choker Hitch	Basket Hitch			
				Angle of Rope to Horizontal			
				90°	60°	45°	30°
				Angle of Rope to Vertical			
				0°	30°	45°	60°
1/2	4.7	1,160	580	2,320	2,010	1,640	1,160
9/16	6.1	1,400	700	2,810	2,430	1,990	1,400
5/8	7.5	1,710	855	3,420	2,960	2,420	1,710
3/4	10.7	2,340	1,170	4,680	4,050	3,310	2,340
13/16	12.7	2,740	1,370	5,470	4,740	3,870	2,740
7/8	15.0	3,170	1,580	6,340	5,490	4,480	3,170
1	18.0	3,850	1,930	7,700	6,670	5,450	3,860
1-1/16	20.4	4,410	2,210	8,820	7,640	6,240	4,410
1-1/8	23.7	5,040	2,520	10,100	8,730	7,130	5,040
1-1/4	27.0	5,780	2,890	11,600	10,000	8,170	5,780
1-5/16	30.5	6,480	3,240	13,000	11,200	9,170	6,480
1-1/2	38.5	8,170	4,090	16,300	14,200	11,600	8,170
1-5/8	47.5	9,920	4,960	19,800	17,200	14,000	9,920
1-3/4	57.0	11,800	5,920	23,700	20,500	16,800	11,800
2	69.0	14,300	7,160	28,700	24,800	20,300	14,300
2-1/8	80.0	16,800	8,400	33,600	29,100	23,800	16,800
2-1/4	92.0	19,100	9,540	38,200	33,100	27,000	19,100
2-1/2	107.0	22,000	11,000	43,900	38,000	31,100	22,000
2-5/8	120.0	24,800	12,400	49,700	43,000	35,100	24,800